

# Digital Multi Switcher

## MSD-62 Series

MSD-6203/MSD-6204

<Command Reference Guide>

Ver.1.4.0

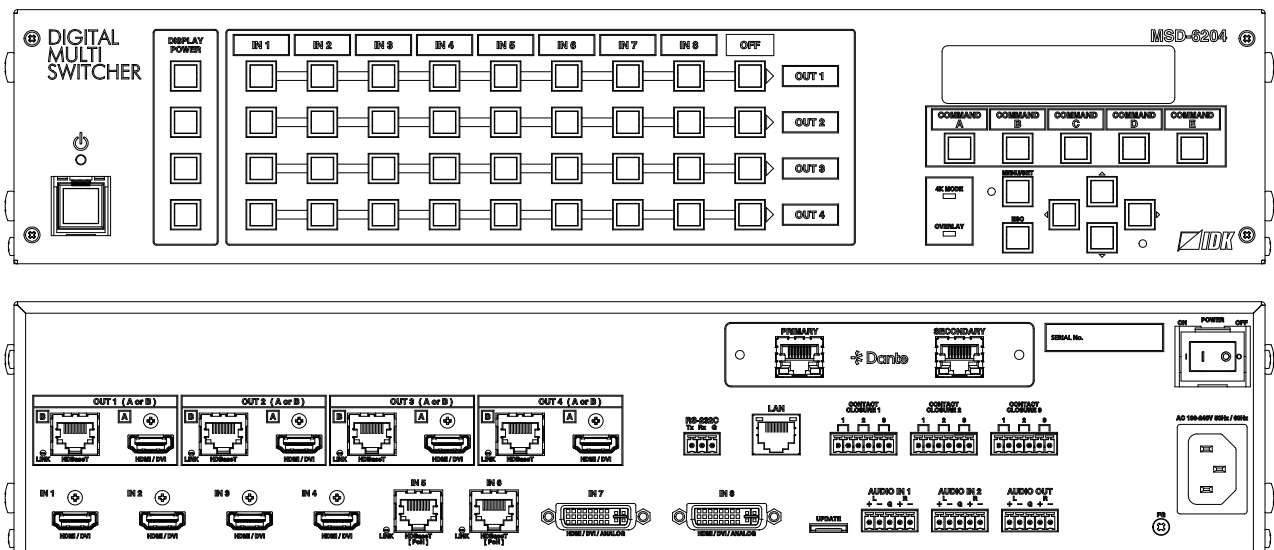

- Thank you for choosing our product.
- To ensure the best performance of this product, please read this user guide fully and carefully before using it and keep this manual together with the product for future reference as needed.

## **Trademarks**

- HDBaseT™ and the HDBaseT Alliance Logo are trademarks of the HDBaseT Alliance.
- The terms HDMI and HDMI High-Definition Multimedia Interface, and the HDMI Logo are trademarks or registered trademarks of HDMI Licensing Administrator, Inc. in the United States and other countries.
- SDVoE™ and SDVoE logo are trademarks of SDVoE Alliance.
- All other company and product names mentioned in this document are either registered trademarks or trademarks of their respective owners. In this document, the “®” or “™” marks may not be specified.
- ©2018 IDK Corporation, all rights reserved.

# Before reading this manual

- All rights reserved.
- Some information contained in this User guide such as exact product appearance, diagrams, menu operations, communication commands, and so on may differ depending on the product version.
- This User guide is subject to change without notice. You can download the latest version from IDK's website at: [www.idkav.com](http://www.idkav.com)

The reference manual consists of the following two volumes:

- User guide: Please download the command guide from the website above.  
Provides explanations and procedures for operations, installation, connections among devices, I/O adjustment and settings.
- Command guide (this document):  
Provides explanations and procedures for external control using RS-232C and LAN communications.

## Table of Contents

1	About this Guide .....	5
2	Communication configuration and Specifications .....	6
2.1	RS-232C communication .....	6
2.1.1	Connecting RS-232C cable.....	6
2.1.2	RS-232C communication specification .....	6
2.1.3	Setting up RS-232C communication .....	7
2.2	LAN communication.....	8
2.2.1	LAN connector specification.....	8
2.2.2	LAN communication specification .....	8
2.2.3	Setting up LAN communication.....	9
2.2.4	The number of TCP-IP connections.....	11
3	Command.....	12
3.1	Command outline.....	12
3.2	Command list .....	13
3.3	Detailed descriptions.....	18
3.3.1	Error status .....	18
3.3.2	Power status.....	19
3.3.3	Input channels .....	19
3.3.4	Position, size, and masking.....	21
3.3.5	Video processing.....	33
3.3.6	Image quality .....	35
3.3.7	Input settings .....	40
3.3.8	Input timing .....	45
3.3.9	Output settings .....	52
3.3.10	Audio .....	62
3.3.11	EDID.....	70
3.3.12	RS-232C communication .....	77
3.3.13	LAN communication .....	81
3.3.14	Control commands .....	85
3.3.15	Preset memory .....	99
3.3.16	Bitmap .....	105
3.3.17	Other settings.....	112

# 1 About this Guide

---

This guide contains the procedure for controlling the MSD-62 series using commands via RS-232C communication or LAN communication.

■ You can perform the following operations using communication commands.

- Switching channels.
- Setting I/O, audio, and EDID.
- Setting sending of external control command.
- Setting preset memory.
- Setting and displaying bitmaps and others

## 2 Communication configuration and Specifications

### 2.1 RS-232C communication

#### 2.1.1 Connecting RS-232C cable

The MSD's RS-232C connection is supported by a 3-position terminal block.

Insert and secure the wires from the RS-232C cable into the supplied 3-position terminal block, and then insert the terminal block into the mating connector on the MSD.

AWG24 to AWG16 conductor gauge is recommended. The recommended wire strip length is 0.28 in. (7 mm). Short RTS/CTS and DTR/DSR as needed.

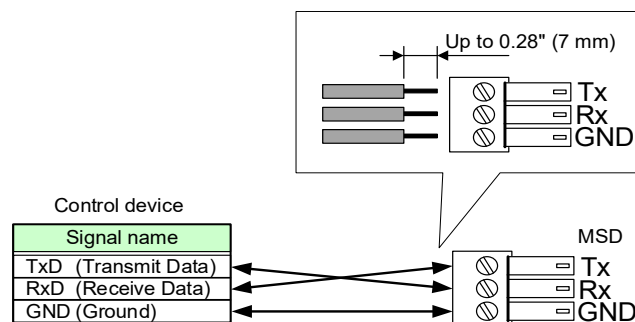

[Fig. 2.1] Connecting RS-232C cable into 3-position terminal block

#### 2.1.2 RS-232C communication specification

[Table 2.1] RS-232C specification

Standard	RS-232C
Baud rate [bps]	4800/9600/19200/38400 [bps]
Data bit length [bit]	7/8
Parity check	NONE, EVEN, ODD
Stop bit [bit]	1/2
X parameter	Invalid
Flow control	None
Delimiter	CR LF (Carriage return and line feed, 0D and 0A in hex)
Communication method	Full duplex

## 2.1.3 Setting up RS-232C communication

- (1) Connect the MSD and the control device via an RS-232C cable.
  - (2) Set the RS-232C communication as follows:
    - RS-232C communication: Baud rate, data bit length, parity check, and stop bit
    - Operation mode of RS-232C communication: "RECEIVER"
- 【Reference: User Guide】
- (3) For the control device, set the same values in the same way as RS-232C communication (baud rate, data bit length, parity check, and stop bit) in step (2) above.
  - (4) Send a communication command from the control device to the MSD in order to check the control status of the MSD.

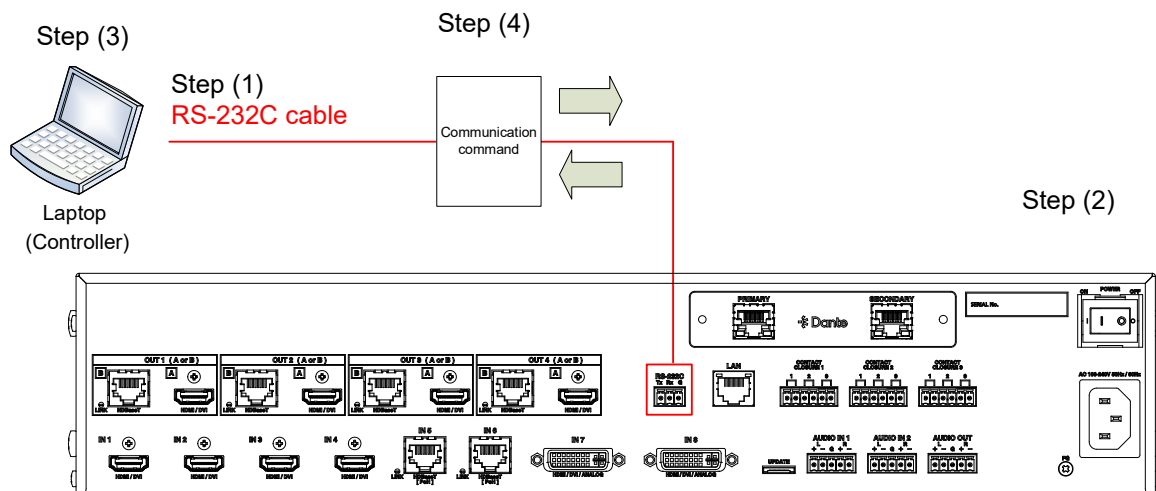

[Fig. 2.2] Setting RS-232C communication (Example: MSD-6204 with Dante)

### ■ Operation example of RS-232C communication

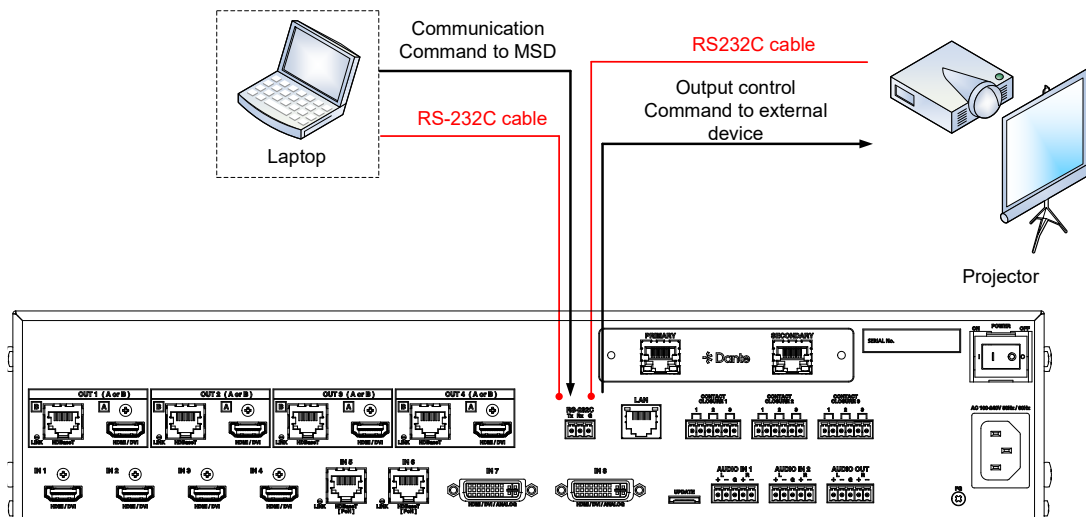

[Fig. 2.3] RS-232C communication (Example: MSD-6204 with Dante)

## 2.2 LAN communication

### 2.2.1 LAN connector specification

It supports Auto MDI/MDI-X, which distinguishes/switches straight and cross cables automatically.

Pin assignments of LAN connector:

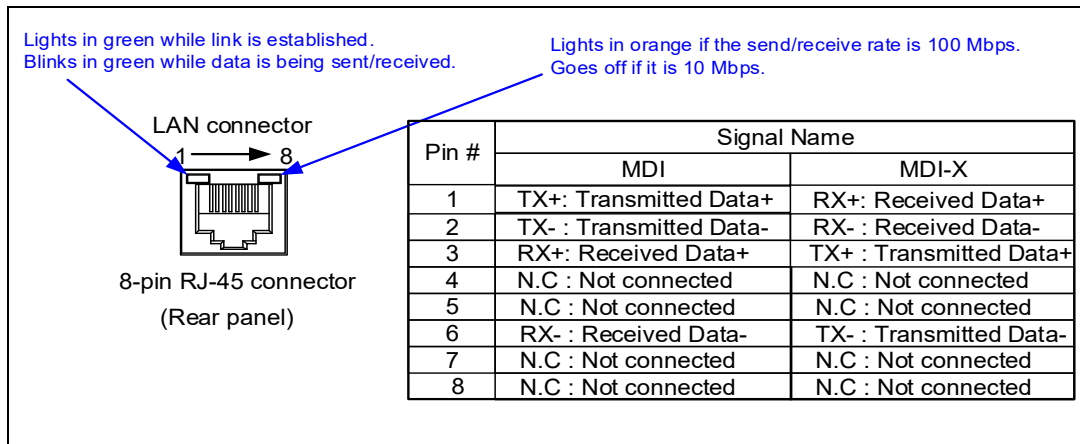

[Fig. 2.4] LAN connector

### 2.2.2 LAN communication specification

[Table 2.2] Specification of LAN communication

Physical layer	10Base-T (IEEE802.3i) / 100Base-TX (IEEE802.3u)
Network layer	ARP, IP, ICMP
Transport layer	TCP
	Port used for command control: 23, 1100, 6000 to 6999 Port used for WEB browser control (HTTP): 80, 5000 to 5999

**Note:** Up to 8 connections can be used simultaneously.

## 2.2.3 Setting up LAN communication

(1) Connect the MSD and the control device via a LAN cable.

(2) Set up LAN communication as follows:

- Set IP address and subnet mask
- Operation mode of LAN communication: "RECEIVER"
- TCP port number: 23, 1100, 6000 to 6999

【Reference: User Guide】

(3) Establish the connection from the control device to the IP address and TCP port that are set to the MSD in step (2) above.

(4) Send a communication command from the control device to the MSD in order to check the control status of the MSD.

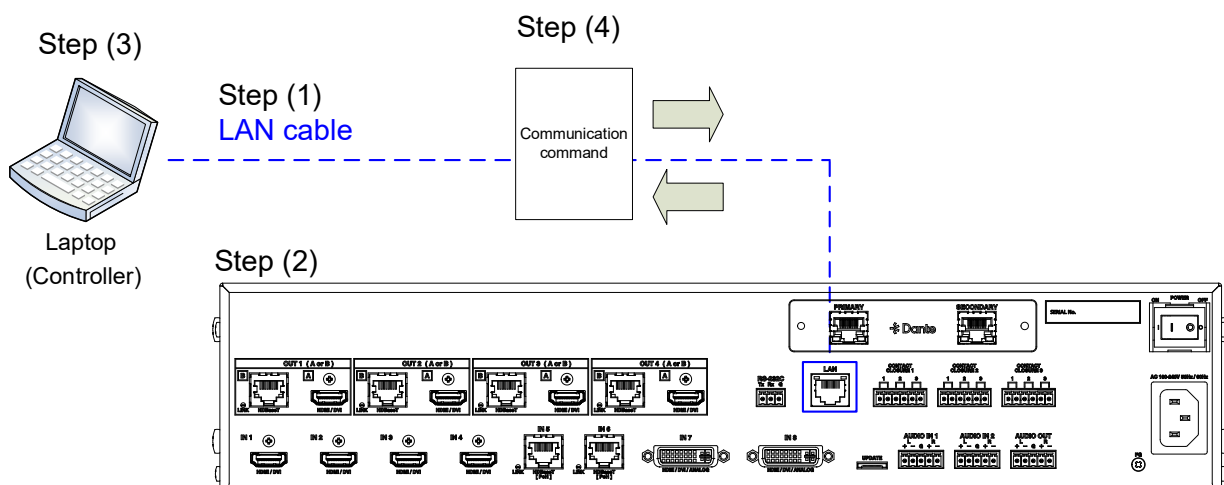

[Fig. 2.5] Setting LAN communication (Example: MSD-6204 with Dante)

■ Operation example of LAN communication

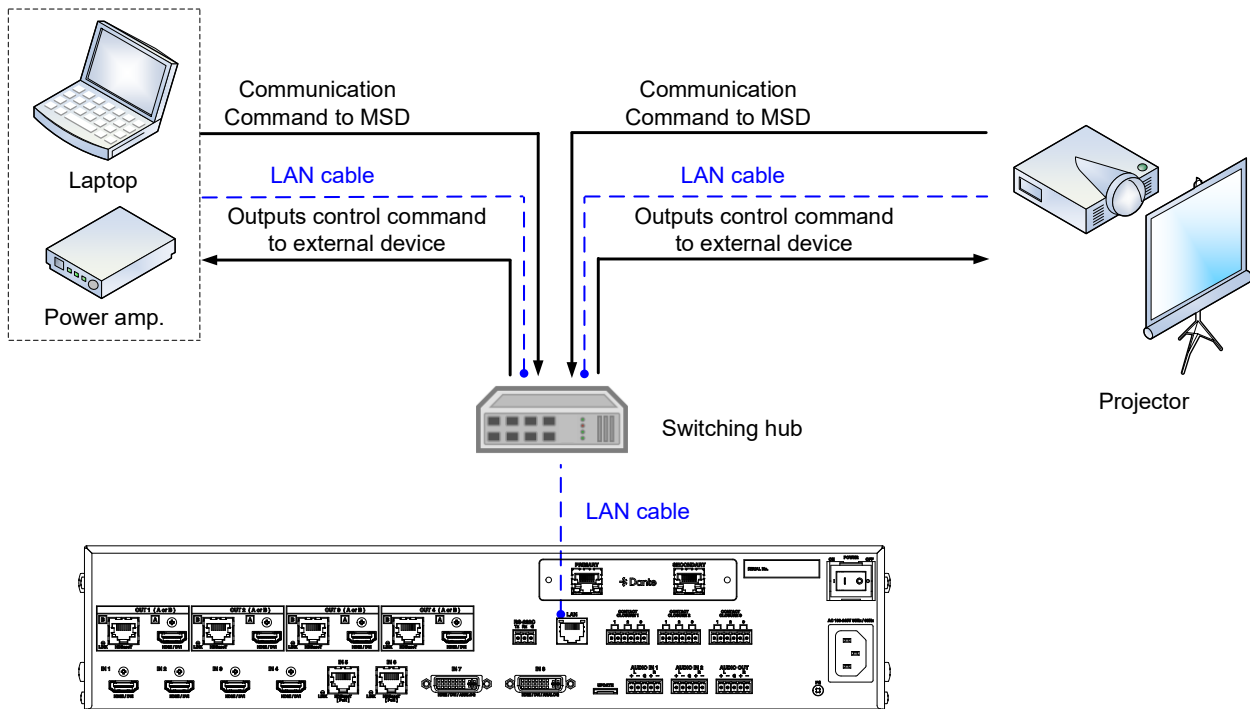

[Fig. 2.6] Example of LAN communication (Example: MSD-6204 with Dante)

## 2.2.4 The number of TCP-IP connections

---

The MSD series can connect up to eight connections (eight ports) simultaneously. If the MSD is controlled from nine or more PCs, they may not be connected to the MSD normally, since the number of connections that can be used is limited.

If you use nine connections or more, execute TCP-IP connection/close every time the communication command is sent or received from the software of user's side. By doing so, MSD's ports are occupied or released so that nine or more connections can be connected logically.

**[Table 2.3] Increasing connections**

Your PC software		MSD
TCP-IP connection	→	(Occupied by 1 port)
Send command (@xxx)	→	
	←	Send back command (@xxx)
TCP-IP close	→	(Release 1 port)

**Note:**

If any command is not sent from the PC side to the MSD for 30 seconds, the MSD disconnects the connection to avoid the limitation problem on the number of connections. As a result, connection needs to be established again from the PC side after the current connection of the PC is disconnected.

(Since the number of ports in the MDS is eight, ports are occupied permanently if the PC is turned off while connections are valid. To prevent this, the MSD disconnects connections if no communication command is sent from the PC side.)

## 3 Command

---

### 3.1 Command outline

---

A command consists of “@” (“40” in hexadecimal), 3 one-byte alphabetical characters (upper and lower cases), and parameters (one-byte numbers\*). For some commands, several parameters can be specified or no parameter is required. Processing is executed by sending a delimiter at the end of the command.

Example: @SPM,2 ↵

“,”( a comma, “2C” in hexadecimal) is indicated between a command and parameter and between two parameters.

#### ■ If there is an error:

An error command is returned if an undefined command or wrong parameter is included.

Example: @SOT,1 ↵  
 @ERR,1 ↵

#### ■ Using as HELP

If only delimiter is sent, command list as the help command is returned.

Example: ↵

```

----- HELP (1/14) -----↵
(CHANNEL SELECT Command) ↵
@GSW / @SSW : Get/Set Input Channel↵
@GSV / @SSV : Get/Set Video Input Channel↵
@GSA / @SSA : Get/Set Audio Input Channel↵
  
```

## 3.2 Command list

### ■ Error status

Command	Function	Page
@ERR	Error status	18

### ■ Power status

Command	Function	Page
@GPS / @SPS	Standby button	19

### ■ Input channels

Command	Function	Page
@GSW / @SSW	Switching video and audio channel simultaneously	19
@GSV / @SSV	Switching video channel	20
@GSA / @SSA	Switching audio channel	20

### ■ Position, size, and masking

Command	Function	Page
@GOT / @SOT	Output resolution	21
@GTD	Actual output resolution	22
@GUM / @SUM	Aspect ratio of sink device	23
@GAP / @SAP	Aspect ratio	23
@GAR / @SAR	Aspect ratio restoration	24
@GOV / @SOV	Overscan	24
@GNP / @SNP	Input position	25
@GNS / @SNS	Input size	26
@GNM / @SNM	Input masking	27
@IAS	Input automatic sizing	27
@GOP / @SOP	Output position	28
@GOS / @SOS	Output size	29
@GOM / @SOM	Output masking	30
@OAS	Output automatic sizing	30
@GBC / @SBC	Background color	31
@GTP / @STP	Test pattern	32

### ■ Video processing

Command	Function	Page
@GOR / @SOR	Video processing mode	33
@GPR / @SPR	Window display priority	33
@GOI / @SOI	Flip horizontal	34
@GWV / @SWV	Hiding window	34

### ■ Image quality

Command	Function	Page
@GFL / @SFL	Sharpness	35
@GBR / @SBR	Input brightness	35
@GCO / @SCO	Input contrast	36
@GHU / @SHU	Hue	36
@GST / @SST	Saturation	37
@GSU / @SSU	Black level	37
@IDC	Input default color	38
@GOB / @SOB	Output brightness	38
@GOC / @SOC	Output contrast	39
@GGM / @SGM	Output gamma	39
@ODC	Output default color	40

### ■ Input settings

Command	Function	Page
@GDT / @SDT	No-signal-input monitoring	40
@GHE / @SHE	HDCP input enabled/disabled	41
@GAI / @SAI	Analog input type	41
@GID / @SID	Automatic detection of input video interruption	42
@GIN / @SIN	Signal selection of DVI input connector	42
@GIA / @SIA	HDBaseT input long reach mode	43
@GFX / @SFX	Fixing settings for input signal	44

### ■ Input timing

Command	Function	Page
@AIS / @AIT	Automatic measurement	45
@GHT / @SHT	The total number of horizontal dots	46
@GHS / @SHS	Horizontal start position	47
@GHD / @SHD	Horizontal display period	47
@GVS / @SVS	Vertical start position	48
@GVD / @SVD	Vertical display period	48
@GIS / @SIS	Automatic measurement of start position	49
@GSM / @SSM	Automatic measurement when unregistered signal is input	49
@RTT	Loading device data	50
@STT	Registering device data	50
@GTK / @STK	Tracking	51

## ■ Output settings

Command	Function	Page
@GEQ / @SEQ	Output equalizer	52
@GDM / @SDM	Output mode	52
@GUY / @SUY	Synchronous signal output when no video signal is input	53
@GBO / @SBO	Output video when no video signal is not input	53
@GFF / @SFF	Video switching effect	54
@GFT / @SFT	Video switching speed	54
@GWC / @SWC	Wipe color	55
@GVO / @SVO	HDMI / HDBaseT output	56
@GEN / @SEN	HDCP output	57
@GHR / @SHR	The number of HDCP retries	57
@GDC / @SDC	Deep Color	58
@GCE / @SCE	CEC connection	58
@HAU	HDCP re-encryption	59
@GAU / @SAU	Priority of input channel automatic switching (OFF to ON)	59
@GOF / @SOF	Priority of input channel automatic switching (ON to OFF)	60
@GMT / @SMT	Masking time after automatic switching of input channel	60
@GAD / @SAD	Channel switching mode for input channel automatic switching	61
@GOA / @SOA	HDBaseT output long reach mode	61

## ■ Audio

Command	Function	Page
@GSL / @SSL	Audio output level	62
@SOL	Relative value of audio output level	62
@GOL	Limit status of audio output level	63
@GAM / @SAM	Audio output mute	63
@GAS / @SAS	Selecting audio input	64
@GSO / @SSO	Audio input level	65
@SIL	Relative value of audio input level	65
@GIL	Limit status of audio input level	65
@GLO / @SLO	Output lip sync	66
@GLY / @SLY	Input lip sync	66
@GSF / @SSF	Sampling frequency	67
@GFD	Actual sampling frequency	67
@GCS / @SCS	Analog audio output	68
@GMD / @SMD	Multi channel audio output	68
@GAT / @SAT	Test tone	69

### ■ EDID

Command	Function	Page
@GED / @SED	EDID	70
@GVF / @SVF	Input resolution for PC	71
@GHF / @SHF	Input resolution for AV devices	72
@GDI / @SDI	Deep Color input	73
@GAF / @SAF	Audio format	74
@GSP / @SSP	The number of speakers (cont'd)	76
@RME	Copying EDID	76

### ■ RS-232C communication

Command	Function	Page
@GCT / @SCT	RS-232C communication	77
@GCF / @SCF	RS-232C communication mode	78
@GCI / @SCI	RS-232C transmission	79
@GCQ / @SCQ	RS-232C HDBaseT sending channel	80
@GCR / @SCR	RS-232C HDBaseT receiving channel	80

### ■ LAN communication

Command	Function	Page
@GIP / @SIP	IP address	81
@GSB / @SSB	Subnet mask	82
@GGW / @SGW	Gateway address	82
@GLF / @SLF	LAN communication mode	83
@GLP / @SLP	TCP port number	84
@GMC	MAC address	84

### ■ Control commands

Command	Function	Page
@EXC	Executing control commands	85
@GDS / @SDS	Power button of sink device	85
@GEC / @SEC	Control command (Communication command)	86
@GEC / @SEC	Control command (Displaying received data)	88
@GEC / @SEC	Control command (contact closure)	90
@GEC / @SEC	Control command (CEC)	91
@GRC / @SRC	Response command	92
@GCC / @SCC	Control command link	93
@GTG / @STG	Toggle operation	95
@GUP / @SUP	Plane to be executed when powered ON	95
@GIT / @SIT	Ineffective time during control command execution	96
@DEC	Initializing registered command and link	96
@GTL / @STL	Lighting condition of execution button	97
@GTF / @STF	Blinking time of sink device power switch	98

### ■ Preset memory

Command	Function	Page
@RCM	Loading crosspoint memory	99
@SCM / @SEM	Saving channels to crosspoint memory	99
@GCM / @ECM	Editing crosspoint memory	100
@RCV	Loading crosspoint memory (setting video channel)	100
@SCV / @SEV	Saving crosspoint memory (Setting video channel)	101
@GCV / @ECV	Editing crosspoint memory (Setting video channel)	101
@RCA	Loading audio channel setting from crosspoint memory	102
@SCA / @SEA	Saving crosspoint memory (Setting audio channel)	102
@GCA / @ECA	Editing crosspoint memory (Setting audio channel)	103
@RPM	Loading all settings	103
@SPM	Saving all settings	104
@SCP	Copying output setting	104
@GMU / @SMU	Startup settings	105

### ■ Bitmap

Command	Function	Page
@GBM / @SBM	Outputting bitmap image	105
@GBB / @SBB	Background color	106
@GBT / @SBT	Aspect ratio	107
@GZP / @SZP	Display position	108
@GBA / @SBA	Assigning input channel	109
@GPB / @SPB	Startup bitmap	109
@GBD / @SBD	Dividing memory area	110
@GBV	Memory area status	110
@GFZ / @SFZ	Freeze	111
@CAP	Capturing input image	111



### ■ Other settings

Command	Function	Page
@GLS / @SLS	Operation lock	112
@GLM / @SLM	Setting operation to be locked	112
@GBZ / @SBZ	Buzzer	113
@GHP / @SHP	Power supply of HDBaseT input	113
@GSS	I/O status	114
@GES	Monitor's EDID	118
@GIV	Version	118

### 3.3 Detailed descriptions

Command formats for MSD-6204 are shown in this section. For other models, use each appropriate command formats according to the number of outputs.

#### 3.3.1 Error status









<b>@ERR</b>		<b>Error status</b>
Description		Response in case the command is not executed.
Response		@ERR, error 
Parameter		error: Error status 1 = Erroneous parameter format or value 2 = Undefined command or wrong format 3 = Currently cannot be used. 4 = Not used. 5 = The command could not be executed, because the control command was not registered. 6 = The command could not be processed since another command was being executed. 7 = Automatic measurement of input timing failed. 8 = Loading EDID from the sink device failed. 9 = Not used. 10 = The control command was stopped according to the stop condition. 11 = The control command was stopped since the number of retries exceeded the set value of "RETRY". 12 = The control command of PJLink was stopped since the password did not match. 13 = The image could not be captured since the image size to be captured exceeded the reserved memory size. 14 = Capturing input image failed.
Getting example	Command	Command @IOS 
	Response	Response @ERR,2 
	Description	@IOS is sent. Command format error.
Remarks		—









### 3.3.2 Power status

@GPS / @SPS		Standby button
Getting	Command	@GPS ↵
	Response	@GPS, onoff ↵
Setting	Command	@SPS, onoff ↵
	Response	@SPS, onoff ↵
Parameter		onoff: Standby button 0 = OFF (Standby), 1 = ON (Power on)
Getting example	Command	@GPS ↵
	Response	@GPS,1 ↵
	Description	Getting the standby button status. It is powered on.
Setting example	Command	@SPS,1 ↵
	Response	@SPS,1 ↵
	Description	Setting the standby button to ON (powered on).
Remarks		—

### 3.3.3 Input channels





@GSW / @SSW		Switching video and audio channel simultaneously
Getting	Command	@GSW ↵
	Response	@GSW, video_1, audio_1, video_2, audio_2, ..., video_4, audio_4 ↵
Setting	Command	@SSW, input_1, output_1 (, input_2, output_2...) ↵
	Response	@SSW, input_1, output_1 (, input_2, output_2...) ↵
Parameter		video_1-4 : Video input channel audio_1-4 : Audio input channel input_1-4 : Video and audio input channel 0 = OFF [Default], 1 = IN1 to 8 = IN8 output_1-4: Video and audio output channel 0 = All outputs, 1 = OUT1 to 4 = OUT4
Getting example	Command	@GSW ↵
	Response	@GSW,2,2,2,2,0,0,0,0 ↵
	Description	Getting the video and audio input channels that are assigned to output channels. OUT1 and OUT2: IN2, OUT3 and OUT4: OFF
Setting example	Command	@SSW,1,1 ↵
	Response	@SSW,1,1 ↵
	Description	Setting IN1 video and audio to be output to OUT1.
Remarks		—

<b>@GSV / @SSV</b>		<b>Switching video channel</b>
Getting	Command	@GSV 
	Response	@GSV, input_1, input_2, input_3, input_4 
Setting	Command	@SSV, input_1, output_1 (, input_2, output_2···) 
	Response	@SSV, input_1, output_1 (, input_2, output_2···) 
Parameter		input_1-4: Video input channel 0 = OFF [Default], 1 = IN1 to 8 = IN8
		output_1-4: Video output channel 0 = All outputs, 1 = OUT1 to 4 = OUT4
Getting example	Command	@GSV 
	Response	@GSV,1,1,2,2 
	Description	Getting the video I/O channel statuses. OUT1 and OUT2: IN1, OUT3 and OUT4: IN2
Setting example	Command	@SSV,1,1 
	Response	@SSV,1,1 
	Description	Setting IN1 video to be output to OUT1.
Remarks		—

<b>@GSA / @SSA</b>		<b>Switching audio channel</b>
Getting	Command	@GSA 
	Response	@GSA, input_1, input_2, input_3, input_4 
Setting	Command	@SSA, input_1, output_1 (, input_2, output_2···) 
	Response	@SSA, input_1, output_1 (, input_2, output_2···) 
Parameter		input_1-4: Audio input channel 0 = OFF [Default], 1 = IN1 to 8 = IN8
		output_1-4: Audio output channel 0 = All outputs, 1 = OUT1 to 4 = OUT4
Getting example	Command	@GSA 
	Response	@GSA,1,1,2,2 
	Description	Getting the audio I/O channel status. OUT1 and OUT2: IN1, OUT3 and OUT4: IN2
Setting example	Command	@SSA,1,1 
	Response	@SSA,1,1 
	Description	Setting IN1 audio to be output to OUT1.
Remarks		—

### 3.3.4 Position, size, and masking

@GOT / @SOT		Output resolution
Getting	Command	@GOT [↵]
	Response	@GOT, resolution_1, resolution_2, resolution_3, resolution_4 [↵]
Setting	Command	@SOT, ch_1, resolution_1 (, ch_2, resolution_2···) [↵]
	Response	@SOT, ch_1, resolution_1 (, ch_2, resolution_2···) [↵]
Parameter		resolution_1-4: Setting value of output resolution 0 = AUTO [Default], 3 = XGA@60 (1024x768), 4 = WXGA@60 (1280x768), 5 = WXGA@60 (1280x800), 6 = Quad-VGA@60 (1280x960), 7 = SXGA@60 (1280x1024), 8 = WXGA@60 (1360x768), 9 = WXGA@60 (1366x768), 10 = SXGA+@60 (1400x1050), 11 = WXGA+@60 (1440x900), 12 = WXGA++@60 (1600x900), 13 = UXGA@60 (1600x1200), 14 = WSXGA+@60 (1680x1050), 15 = VESAHD@60 (1920x1080), 16 = WUXGA@60 (1920x1200), 17 = QWXGA@60 (2048x1152), 24 = 720p@50 (1280x720), 25 = 720p@59.94 (1280x720), 26 = 720p@60 (1280x720), 27 = 1080i@50 (1920x1080), 28 = 1080i@59.94 (1920x1080), 29 = 1080i@60 (1920x1080), 30 = 1080p@50 (1920x1080), 31 = 1080p@59.94(1920x1080), 32 = 1080p@60 (1920x1080), 40 = 2160p@24 (3840x2160), 41 = 2160p@25 (3840x2160), 42 = 2160p@30 (3840x2160), 45 = 2160p@24 (4096x2160), 46 = 2160p@25 (4096x2160), 47 = 2160p@30 (4096x2160)
		ch_1-4: Output channel 0 = All outputs, 1 = OUT1 to 4 = OUT4
Getting example	Command	@GOT [↵]
	Response	@GOT,7,7,31,31 [↵]
	Description	Getting the set output resolution. OUT1 and OUT2: SXGA, OUT3 and OUT4: 1080p 59.94 Hz
Setting example	Command	@SOT,1,31 [↵]
	Response	@SOT,1,31 [↵]
	Description	Setting output resolution of OUT1 to 1080p 59.94 Hz.
Remarks		—

<b>@GTD</b>		<b>Actual output resolution</b>
Getting	Command	@GTD 
	Response	@GTD, resolution_1, resolution_2, resolution_3, resolution_4 
Parameter		resolution_1-4: Actual output resolution 1 = VGA@60 (640x480), 2 = SVGA@60 (800x600), 3 = XGA@60 (1024x768), 4 = WXGA@60 (1280x768), 5 = WXGA@60 (1280x800), 6 = Quad-VGA@60 (1280x960), 7 = SXGA@60 (1280x1024), 8 = WXGA@60 (1360x768), 9 = WXGA@60 (1366x768), 10 = SXGA+@60 (1400x1050), 11 = WXGA+@60 (1440x900), 12 = WXGA++@60 (1600x900), 13 = UXGA@60 (1600x1200), 14 = WSXGA+@60 (1680x1050), 15 = VESAHD@60 (1920x1080), 16 = WUXGA@60 (1920x1200), 17 = QWXGA@60 (2048x1152), 21 = 480p@59.94 (720x480), 23 = 576p@50 (720x576), 24 = 720p@50 (1280x720), 25 = 720p@59.94 (1280x720), 26 = 720p@60 (1280x720), 27 = 1080i@50 (1920x1080), 28 = 1080i@59.94 (1920x1080), 29 = 1080i@60 (1920x1080), 30 = 1080p@50 (1920x1080), 31 = 1080p@59.94 (1920x1080), 32 = 1080p@60 (1920x1080), 40 = 2160p@24 (3840x2160), 41 = 2160p@25 (3840x2160), 42 = 2160p@30 (3840x2160), 45 = 2160p@24 (4096x2160), 46 = 2160p@25 (4096x2160), 47 = 2160p@30 (4096x2160)
Getting example	Command	@GTD 
	Response	@GTD,31,31,26,26 
	Description	Getting the actual output resolution. OUT1 and OUT2: 1080p 59.94 Hz, OUT3 and OUT4: 720p 60 Hz
Remarks		If “@GOT / @SOT Output resolution” is set to “AUTO”, the actual output resolution is returned. If “@GOT / @SOT Output resolution” is set to the value other than “AUTO”, the set output resolution is returned.









<b>@GUM / @SUM</b>		<b>Aspect ratio of sink device</b>
Getting	Command	@GUM
	Response	@GUM, aspect_1, aspect_2, aspect_3, aspect_4
Setting	Command	@SUM, ch_1, aspect_1 (, ch_2, aspect_2···)
	Response	@SUM, ch_1, aspect_1 (, ch_2, aspect_2···)
Parameter		aspect_1-4: Aspect ratio of sink device 0 = RESOLUTION [Default],      1 = 4:3,      2 = 5:4, 3 = 5:3,      4 = 16:9,      5 = 16:10, 6 = 256:135 ch_1-4: Output channel 0 = All outputs, 1 = OUT1 to 4 = OUT4
Getting example	Command	@GUM
	Response	@GUM,4,4,5,5
	Description	Getting the set aspect ratio of the sink device. OUT1 and OUT2: 16:9, OUT3 and OUT4: 16:10
Setting example	Command	@SUM,1,4
	Response	@SUM,1,4
	Description	Setting OUT1 to 16:9.
Remarks		—

<b>@GAP / @SAP</b>		<b>Aspect ratio</b>
Getting	Command	@GAP
	Response	@GAP, aspect_1, aspect_2, aspect_3, ···, aspect_8
Setting	Command	@SAP, ch_1, aspect_1 (, ch_2, aspect_2···)
	Response	@SAP, ch_1, aspect_1 (, ch_2, aspect_2···)
Parameter		aspect_1-8: Aspect ratio of input signal 0 = AUTO-1 [Default],      1 = AUTO-2, 2 = 4:3,      3 = 16:9,      4 = 14:9, 5 = 16:9 LETTER BOX,      6 = 14:9 LETTER BOX,      7 = 4:3 SIDE PANEL, 8 = 14:9 SIDE PANEL,      9 = FULL,      10 = THROUGH ch_1-8: Input channel 0 = All inputs, 1 = IN1 to 8 = IN8
Getting example	Command	@GAP
	Response	@GAP,0,0,2,0,0,0,0,0
	Description	Getting the set aspect ratio. IN3: 4:3, Other inputs: AUTO-1
Setting example	Command	@SAP,7,2
	Response	@SAP,7,2
	Description	Setting IN7 to 4:3.
Remarks		—

<b>@GAR / @SAR</b>		<b>Aspect ratio restoration</b>
Getting	Command	@GAR
	Response	@GAR, mode_1, mode_2, mode_3, ..., mode_8
Setting	Command	@SAR, ch_1, mode_1 (, ch_2, mode_2····)
	Response	@SAR, ch_1, mode_1 (, ch_2, mode_2····)
Parameter		mode_1-8: Aspect ratio restoration 0 = Letter box/Side panel [Default], 1 = Side cut/Top bottom cut
		ch_1-8: Input channel 0 = All inputs, 1 = IN1 to 8 = IN8
Getting example	Command	@GAR
	Response	@GAR,0,0,1,0,0,0,0,0
	Description	Getting the set aspect ratio restoration processing. IN3: Side cut/Top bottom cut, Other inputs: Letter box/Side panel
Setting example	Command	@SAR,5,1
	Response	@SAR,5,1
	Description	Setting IN5 to Side cut/Top bottom cut.
Remarks		—

<b>@GOV / @SOV</b>		<b>Overscan</b>
Getting	Command	@GOV
	Response	@GOV, overscan_1, overscan_2, overscan_3, ..., overscan_8
Setting	Command	@SOV, ch_1, overscan_1 (, ch_2, overscan_2····)
	Response	@SOV, ch_1, overscan_1 (, ch_2, overscan_2····)
Parameter		overscan_1-8: Overscan 100 to 115 [Default] SDTV: 105, HDTV / PC: 100
		ch_1-8: Input channel 0 = All inputs, 1 = IN1 to 8 = IN8
Getting example	Command	@GOV
	Response	@GOV,100,100,105,100,100,100,100,100
	Description	Getting the set overscan. IN3: 105 %, Other inputs: 100 %
Setting example	Command	@SOV,7,105
	Response	@SOV,7,105
	Description	Setting IN7 to 105%.
Remarks		—

@GNP / @SNP		Input position
Getting	Command	@GNP ↵
	Response	@GNP, h_position_1, v_position_1, h_position_2, v_position_2···, h_position_8, v_position_8 ↵
Setting	Command	@SNP, ch_1, h_position_1, v_position_1 (, ch_2, h_position_2, v_position_2···) ↵
	Response	@SNP, ch_1, h_position_1, v_position_1 (, ch_2, h_position_2, v_position_2···) ↵
Parameter		h_position_1-8: Horizontal input position -Horizontal input size to +Horizontal output resolution [Default] 0
		v_position_1-8: Vertical input position -Vertical input size to +Vertical output resolution [Default] 0
		ch_1-8: Input channel 0 = All inputs, 1 = IN1 to 8 = IN8
Getting example	Command	@GNP ↵
	Response	@GNP,-50,20,0,0,0,0,0,0,0,0,0,0,0,0,0,0 ↵
	Description	Getting the set input position. N1: horizontal input display is -50, vertical input display is +20. Other inputs: horizontal and vertical input positions are 0.
Setting example	Command	@SNP,1,-50,20 ↵
	Response	@SNP,1,-50,20 ↵
	Description	Setting IN1 horizontal and vertical input positions are to -50 and +20, respectively.
Remarks		If resolutions differ depending on output, the OUT1 output resolution will be the standard.

@GNS / @SNS		Input size
Getting	Command	@GNS 
	Response	@GNS, h_size_1, v_size_1, h_size_2, v_size_2... , h_size_8, v_size_8 
Setting	Command	@SNS, ch_1, h_size_1, v_size_1 (, ch_2, h_size_2, v_size_2...) 
	Response	@SNS, ch_1, h_size_1, v_size_1 (, ch_2, h_size_2, v_size_2...) 
Parameter		h_size_1-8: Horizontal input size Horizontal output resolution ÷4 to Horizontal output resolution ×4 [Default] Horizontal output resolution
		v_size_1-8: Vertical input size Vertical output resolution ÷4 to Vertical output resolution ×4 [Default] Vertical output resolution
		ch_1-8: Input channel 0 = All inputs, 1 = IN1 to 8 = IN8
Getting example	Command	@GNS 
	Response	@GNS,1925,1084,1920,1080,1920,1080,1920,1080,1920,1080,1920,1080,1920,1080 
	Description	Getting the set input size. Horizontal and vertical display sizes of IN1 are 1925 and 1084, respectively. Other inputs: 1920 and 1080, respectively.
Setting example	Command	@SNS,1,1925,1084 
	Response	@SNS,1,1925,1084 
	Description	Setting IN1 horizontal and vertical input size are 1925 and 1084, respectively.
Remarks		If resolutions differ depending on outputs, the resolution of OUT1 will be the standard.

<b>@GNM / @SNM</b>		<b>Input masking</b>
Getting	Command	@GNM, ch ↵
	Response	@GNM, ch, left, right, top, bottom ↵
Setting	Command	@SNM, ch, left, right, top, bottom ↵
	Response	@SNM, ch, left, right, top, bottom ↵
Parameter		ch: Input channel 1 = IN1 to 8 = IN8  left: Left side masking Horizontal input position to right side masking [Default] 0  right: Right side masking Left side masking to horizontal input position + horizontal input size [Default] Horizontal input size  top: Top side masking Vertical input position to bottom side masking [Default] 0  bottom: Bottom side masking Top side masking to vertical input position +vertical input size [Default] Vertical input size
Getting example	Command	@GNM,1 ↵
	Response	@GNM,1,0,1920,0,1080 ↵
	Description	Getting the set IN1 input masking. Left: 0, right: 1920, top: 0, bottom: 1080
Setting example	Command	@SNM,1,0,1920,0,1080 ↵
	Response	@SNM,1,0,1920,0,1080 ↵
	Description	Setting IN1 input masking to 0 for left, 1920 for right, 0 for top, 1080 for bottom.
Remarks		—

<b>@IAS</b>		<b>Input automatic sizing</b>
Setting	Command	@IAS, ch_1 (, ch_2···) ↵
	Response	@IAS, ch_1 (, ch_2···) ↵
Parameter		ch_1-8: Input channel 0 = All inputs, 1 = IN1 to 8 = IN8
Setting example	Command	@IAS,1 ↵
	Response	@IAS,1 ↵
	Description	Initializing the following settings in order to display images input from IN1 on the full screen:  <b>@GAP / @SAP Aspect ratio</b> <b>@GOV / @SOV Overscan</b> <b>@GNP / @SNP Input position</b> <b>@GNS / @SNS Input size</b> <b>@GNM / @SNM Input masking</b>
Remarks		—

@GOP / @SOP		Output position
Getting	Command	@GOP ↵
	Response	@GOP, h_position_1, v_position_1, h_position_2, v_position_2, h_position_3, v_position_3, h_position_4, v_position_4 ↵
Setting	Command	@SOP, ch_1, h_position_1, v_position_1 (, ch_2, h_position_2, v_position_2···) ↵
	Response	@SOP, ch_1, h_position_1, v_position_1 (, ch_2, h_position_2, v_position_2···) ↵
Parameter		h_position_1-4: Horizontal output position -Horizontal output size to +Horizontal output resolution [Default] 0
		v_position_1-4: Vertical output position -Vertical output size to +Vertical output resolution [Default] 0
		ch_1-4: Output channel 0 = All outputs, 1 = OUT1 to 4 = OUT4
Getting example	Command	@GOP ↵
	Response	@GOP,5,20,5,20,0,0,0,0 ↵
	Description	Getting the set output position. OUT1 and OUT2: horizontal position is +5, vertical position is +20. OUT3 and OUT4: horizontal and vertical positions: 0
Setting example	Command	@SOP,1,5,20 ↵
	Response	@SOP,1,5,20 ↵
	Description	Setting OUT1 horizontal and vertical positions to +5 and +20, respectively.
Remarks		—

<b>@GOS / @SOS</b>		<b>Output size</b>
Getting	Command	@GOS ↵
	Response	@GOS, h_size_1, v_size_1, h_size_2, v_size_2, h_size_3, v_size_3, h_size_4, v_size_4 ↵
Setting	Command	@SOS, ch_1, h_size_1, v_size_1 (, ch_2, h_size_2, v_size_2···) ↵
	Response	@SOS, ch_1, h_size_1, v_size_1 (, ch_2, h_size_2, v_size_2···) ↵
Parameter		<p>h_size_1-4: Horizontal output size Horizontal output resolution÷4 to Horizontal output resolution×4 [Default] Horizontal output resolution</p> <p>v_size_1-4: Vertical output size Vertical output resolution÷4 to Vertical output resolution×4 [Default] Vertical output resolution</p> <p>ch_1-4: Output channel 0 = All outputs, 1 = OUT1 to 4 = OUT4</p>
Getting example	Command	@GOS ↵
	Response	@GOS,1920,1035,1920,1035,1920,1080,1920,1080 ↵
	Description	Getting the set output size. OUT1 and OUT2: horizontal output size is 1920, vertical output size is 1035, respectively. OUT3 and OUT4: horizontal output size is 1920, vertical output size is 1080, respectively.
Setting example	Command	@SOS,1,1920,1080 ↵
	Response	@SOS,1,1920,1080 ↵
	Description	Setting OUT1 horizontal and vertical output sizes to 1920 and 1080, respectively.
Remarks		—

<b>@GOM / @SOM</b>		<b>Output masking</b>
Getting	Command	@GOM, ch
	Response	@GOM, ch, left, right, top, bottom
Setting	Command	@SOM, ch, left, right, top, bottom
	Response	@SOM, ch, left, right, top, bottom
Parameter		<p>ch: Output channel 1 = OUT1 to 4 = OUT4</p> <p>left: Left side masking Horizontal output position (0 or larger) to right side masking [Default] 0</p> <p>right: Right side masking Left side masking to Horizontal output position + horizontal output size (horizontal output resolution or smaller) [Default] Horizontal output resolution</p> <p>top: Top side masking Vertical output position (0 or larger) to bottom side masking [Default] 0</p> <p>bottom: Bottom side masking Top side masking to vertical output position + vertical output size (vertical output resolution or smaller) [Default] Vertical output resolution</p>
Getting example	Command	@GOM,1
	Response	@GOM,1,0,1920,0,1080
	Description	Getting the set OUT1 output masking. Left: 0, right: 1920, top: 0, bottom: 1080
Setting example	Command	@SOM,1,0,1920,0,1080
	Response	@SOM,1,0,1920,0,1080
	Description	Setting OUT1 output masking to 0 for left, 1920 for right, 0 for top, and 1080 for bottom.
Remarks		—

<b>@OAS</b>		<b>Output automatic sizing</b>
Setting	Command	@OAS, ch_1 (, ch_2···)
	Response	@OAS, ch_1 (, ch_2···)
Parameter		<p>ch_1-4: Output channel 0 = All outputs, 1 = OUT1 to 4 = OUT4</p>
Setting example	Command	@OAS,1
	Response	@OAS,1
	Description	<p>Initializing the following settings in order to display OUT1 output images on the full screen:</p> <p><b>@GOP / @SOP Output position</b></p> <p><b>@GOS / @SOS Output size</b></p> <p><b>@GOM / @SOM Output masking</b></p>
Remarks		—

<b>@GBC / @SBC</b>		<b>Background color</b>
Getting	Command	@GBC, ch <input type="checkbox"/>
	Response	@GBC, ch, red, green, blue <input type="checkbox"/>
Setting	Command	@SBC, ch_1, red_1, green_1, blue_1 (, ch_2, red_2, green_2, blue_2····) <input type="checkbox"/>
	Response	@SBC, ch_1, red_1, green_1, blue_1 (, ch_2, red_2, green_2, blue_2····) <input type="checkbox"/>
Parameter		<p>ch: Output channel 1 = OUT1 to 4 = OUT4</p> <p>ch_1-4: Output channel 0 = All outputs, 1 = OUT1 to 4 = OUT4</p> <p>red / red_1-4 : Background color (Red) green / green_1-4 : Background color (Green) blue / blue_1-4 : Background color (Blue) 0 to 255 [Default] 0 (Black)</p>
Getting example	Command	@GBC,1 <input type="checkbox"/>
	Response	@GBC,1,128,128,128 <input type="checkbox"/>
	Description	Getting the set OUT1 background color. RGB: 128 (Gray)
Setting example	Command	@SBC,1,128,128,128 <input type="checkbox"/>
	Response	@SBC,1,128,128,128 <input type="checkbox"/>
	Description	Setting OUT1 background color to 128 (Gray) for all RGB.
Remarks		—



### 3.3.5 Video processing

<b>@GOR / @SOR</b>		<b>Video processing mode</b>
Getting	Command	@GOR ↵
	Response	@GOR, mode ↵
Setting	Command	@SOR, mode ↵
	Response	@SOR, mode ↵
Parameter		mode: Video processing mode 0 = Normal mode [Default], 1 = Video combination mode 2 = 4K mode
Getting example	Command	@GOR ↵
	Response	@GOR,2 ↵
	Description	Getting the video processing mode. 4K mode.
Setting example	Command	@SOR,2 ↵
	Response	@SOR,2 ↵
	Description	Setting this menu to 4K mode.
Remarks		—

<b>@GPR / @SPR</b>		<b>Window display priority</b>
Getting	Command	@GPR ↵
	Response	@GPR, priority_1, priority_2, ..., priority_4 ↵
Setting	Command	@SPR, priority_1, priority_2, ..., priority_4 ↵
	Response	@SPR, priority_1, priority_2, ..., priority_4 ↵
Parameter		priority_1-4: Window priority 1 = priority 1 (high) to 4 = priority 4 (low) [Default] 1,2,3,4 (WINDOW1 to WINDOW4) WINDOW1>WINDOW2>WINDOW3>WINDOW4
Getting example	Command	@GPR ↵
	Response	@GPR,2,4,1,3 ↵
	Description	Getting the set window priority: WINDOW1 to WINDOW4: WINDOW3>WINDOW1>WINDOW4>WINDOW2
Setting example	Command	@SPR,4,3,2,1 ↵
	Response	@SPR,4,3,2,1 ↵
	Description	Setting this menu: WINDOW1 to WINDOW 4: WINDOW4>WINDOW3>WINDOW2>WINDOW1
Remarks		Priorities have to be set for all four windows.

<b>@GOI / @SOI</b>		<b>Flip horizontal</b>
Getting	Command	@GOI
	Response	@GOI, flip_1, flip_2, ..., flip_4
Setting	Command	@SOI, window_1, flip_1, (window_2, flip_2, ..., window_4, flip_4)
	Response	@SOI, window_1, flip_1, (window_2, flip_2, ..., window_4, flip_4)
Parameter		flip_1-4: Flip horizontal 0 = OFF [Default], 1 = ON
Getting example	Command	@GOI
	Response	@GOI,0,1,0,0
	Description	Getting the Flip horizontal setting. WINDOW2: Horizontal flip ON Other windows: Horizontal flip OFF
Setting example	Command	@SOI,3,1
	Response	@SOI,3,1
	Description	Setting the WINDOW3 to horizontal flip ON.
Remarks		An error occurs if this menu is set while 4K mode is enabled. 【See: @GOR / @SOR Video processing mode】

<b>@GWV / @SWV</b>		<b>Hiding window</b>
Getting	Command	@GWV
	Response	@GWV, invisible_1, invisible_2, ..., invisible_4
Setting	Command	@SWV, window_1, invisible_1, (window_2, invisible_2, ..., window_4, invisible_4)
	Response	@SWV, window_1, invisible_1, (window_2, invisible_2, ..., window_4, invisible_4)
Parameter		invisible_1-4: Hiding window setting 0 = Display [Default], 1 = Hide window_1-4: Window 0 = All WINDOW, 1 = WINDOW1 to 4 = WINDOW4
Getting example	Command	@GWV
	Response	@GWV,0,1,0,0
	Description	Getting the hiding window setting. WINDOW2: Hide; Other windows: Display
Setting example	Command	@SWV,2,0
	Response	@SWV,2,0
	Description	Setting the WINDOW2 to display.
Remarks		—

### 3.3.6 Image quality

<b>@GFL / @SFL</b>		<b>Sharpness</b>
Getting	Command	@GFL ↵
	Response	@GFL, sharp_1, sharp_2, sharp_3, sharp_4, ..., sharp_8 ↵
Setting	Command	@SFL, ch_1, sharp_1 (, ch_2, sharp_2···) ↵
	Response	@SFL, ch_1, sharp_1 (, ch_2, sharp_2···) ↵
Parameter		sharp_1-8: Input sharpness -5 to +15 [Default] 0
		ch_1-8: Input channel 0 = All inputs, 1 = IN1 to 8 = IN8
Getting example	Command	@GFL ↵
	Response	@GFL,5,0,0,0,0,0,0,0 ↵
	Description	Getting sharpness setting. IN1: +5, other input channels: 0
Setting example	Command	@SFL,1,5 ↵
	Response	@SFL,1,5 ↵
	Description	Setting the IN1 sharpness to +5.
Remarks		—

<b>@GBR / @SBR</b>		<b>Input brightness</b>
Getting	Command	@GBR ↵
	Response	@GBR, bright_1, bright_2, bright_3, bright_4, ..., bright_8 ↵
Setting	Command	@SBR, ch_1, bright_1 (, ch_2, bright_2···) ↵
	Response	@SBR, ch_1, bright_1 (, ch_2, bright_2···) ↵
Parameter		bright_1-8 : Input brightness 80 to 120 [Default] 100
		ch_1-8: Input channel 0 = All inputs, 1 = IN1 to 8 = IN8
Getting example	Command	@GBR ↵
	Response	@GBR,110,100,100,100,100,100,100,100 ↵
	Description	Getting brightness setting. IN1: 110 %, other input channels: 100 %
Setting example	Command	@SBR,3,110 ↵
	Response	@SBR,3,110 ↵
	Description	Setting the IN3 brightness to 110%.
Remarks		—

<b>@GCO / @SCO</b>		<b>Input contrast</b>
Getting	Command	@GCO, ch
	Response	@GCO, ch, red, green, blue
Setting	Command	@SCO, ch_1, red_1, green_1, blue_1 (, ch_2, red_2, green_2, blue_2···)
	Response	@SCO, ch_1, red_1, green_1, blue_1 (, ch_2, red_2, green_2, blue_2···)
Parameter		ch: Input channel 1 = IN1 to 8 = IN8 ch_1-8: Input channel 0 = All inputs, 1 = IN1 to 8 = IN8 red / red_1-8 : Input contrast (Red) green / green_1-8 : Input contrast (Green) blue / blue_1-8 : Input contrast (Blue) 0 to 200 [Default] 100
Getting example	Command	@GCO,3
	Response	@GCO,3,105,100,95
	Description	Getting IN3 contrast setting. Red: 105 %, Green: 100 %, Blue: 95 %
Setting example	Command	@SCO,3,105,100,95
	Response	@SCO,3,105,100,95
	Description	Setting IN3 contrast to 105% for red, 100% for green, 95% for blue.
Remarks		—

<b>@GHU / @SHU</b>		<b>Hue</b>
Getting	Command	@GHU
	Response	@GHU, hue_1, hue_2, hue_3, hue_4, ···, hue_8
Setting	Command	@SHU, ch_1, hue_1 (, ch_2, hue_2···)
	Response	@SHU, ch_1, hue_1 (, ch_2, hue_2···)
Parameter		hue_1-8: Input hue 0 to 359 [Default] 0 ch_1-8: Input channel 0 = All inputs, 1 = IN1 to 8 = IN8
Getting example	Command	@GHU
	Response	@GHU,60,0,0,0,0,0,0
	Description	Getting the set HUEs. IN1: 60°, other inputs: 0°
Setting example	Command	@SHU,1,60
	Response	@SHU,1,60
	Description	Setting IN1 HUE to 60°.
Remarks		Hue can be set up to 359 °. However, if the dot clock of the input signal exceeds 170 MHz, 0 ° is applied regardless of this setting.

<b>@GST / @SST</b>		<b>Saturation</b>
Getting	Command	@GST
	Response	@GST, saturation_1, saturation_2, saturation_3, saturation_4, ..., saturation_8
Setting	Command	@SST, ch_1, saturation_1 (, ch_2, saturation_2...)
	Response	@SST, ch_1, saturation_1 (, ch_2, saturation_2...)
Parameter		saturation_1-8: Input saturation 0 to 200 [Default] 100
		ch_1-8: Input channel 0 = All inputs, 1 = IN1 to 8 = IN8
Getting example	Command	@GST
	Response	@GST,100,100,100,100,105,100,100,100
	Description	Getting the set saturations. IN5: 105 %, other inputs: 100 %
Setting example	Command	@SST,5,105
	Response	@SST,5,105
	Description	Setting IN5 saturation to 105%.
Remarks		Hue can be set up to 200%. However, if the dot clock of the input signal exceeds 170 MHz, 100% is applied regardless of this setting.

<b>@GSU / @SSU</b>		<b>Black level</b>
Getting	Command	@GSU
	Response	@GSU, setup_1, setup_2, setup_3, setup_4, ..., setup_8
Setting	Command	@SSU, ch_1, setup_1 (, ch_2, setup_2...)
	Response	@SSU, ch_1, setup_1 (, ch_2, setup_2...)
Parameter		setup_1-8: Input black level -20 = $-20 \times 0.5$ (-10.0 %) to +20 = $+20 \times 0.5$ (+10.0 %) [Default] $\pm 0 = \pm 0.0$ %
		ch_1-8: Input channel 0 = All inputs, 1 = IN1 to 8 = IN8
Getting example	Command	@GSU
	Response	@GSU,0,0,0,0,15,0,0,0
	Description	Getting the input black level. IN5: +7.5%, other inputs: 0%.
Setting example	Command	@SSU,5,15
	Response	@SSU,5,15
	Description	Setting the IN5 black level to +7.5%.
Remarks		—

<b>@IDC</b>		<b>Input default color</b>
Setting	Command	@IDC, ch_1 (, ch_2···) ↵
	Response	@IDC, ch_1 (, ch_2···) ↵
Parameter		ch_1-8: Input channel 0 = All inputs, 1 = IN1 to 8 = IN8
Setting example	Command	@IDC,1 ↵
	Response	@IDC,1 ↵
	Description	Initialize the following settings of IN1: <b>@GFL / @SFL Sharpness</b> <b>@GBR / @SBR Input brightness</b> <b>@GCO / @SCO Input contrast</b> <b>@GHU / @SHU Hue</b> <b>@GST / @SST Saturation</b> <b>@GSU / @SSU Black level</b>
Remarks		—

<b>@GOB / @SOB</b>		<b>Output brightness</b>
Getting	Command	@GOB ↵
	Response	@GOB, bright_1, bright_2, bright_3, ···, bright_4 ↵
Setting	Command	@SOB, ch_1, bright_1 (, ch_2, bright_2···) ↵
	Response	@SOB, ch_1, bright_1 (, ch_2, bright_2···) ↵
Parameter		bright_1-4: Output brightness 80 to 120 [Default] 100 ch_1-4: Output channel 0 = All outputs, 1 = OUT1 to 4 = OUT4
Getting example	Command	@GOB ↵
	Response	@GOB,110,110,100,100 ↵
	Description	Getting the output brightness. OUT1 and OUT2: 110 %, OUT3 and OUT4: 100 %
Setting example	Command	@SOB,1,110 ↵
	Response	@SOB,1,110 ↵
	Description	Setting the OUT1 brightness to 110%.
Remarks		—

<b>@GOC / @SOC</b>		<b>Output contrast</b>
Getting	Command	@GOC, ch <a href="#">↵</a>
	Response	@GOC, ch, red, green, blue <a href="#">↵</a>
Setting	Command	@SOC, ch_1, red_1, green_1, blue_1 (, ch_2, red_2, green_2, blue_2····) <a href="#">↵</a>
	Response	@SOC, ch_1, red_1, green_1, blue_1 (, ch_2, red_2, green_2, blue_2····) <a href="#">↵</a>
Parameter		<p>ch: Output channel 1 = OUT1 to 4 = OUT4</p> <p>ch_1-4: Output channel 0 = All outputs, 1 = OUT1 to 4 = OUT4</p> <p>red / red_1-4 : Output contrast (Red) green / green_1-4 : Output contrast (Green) blue / blue_1-4 : Output contrast (Blue) 0 to 200 [Default] 100</p>
Getting example	Command	@GOC,1 <a href="#">↵</a>
	Response	@GOC,1,105,100,95 <a href="#">↵</a>
	Description	Getting the OUT1 contrast setting. Red: 105%, green: 100%, blue: 95%
Setting example	Command	@SOC,1,105,100,95 <a href="#">↵</a>
	Response	@SOC,1,105,100,95 <a href="#">↵</a>
	Description	Setting the OUT1 contrast to 105% for red, 100% for green, 95% for blue.
Remarks		—

<b>@GGM / @SGM</b>		<b>Output gamma</b>
Getting	Command	@GGM <a href="#">↵</a>
	Response	@GGM, out_1, out_2, out_3, out_4 <a href="#">↵</a>
Setting	Command	@SGM, ch_1, gamma_1 (, ch_2, gamma_2····) <a href="#">↵</a>
	Response	@SGM, ch_1, gamma_1 (, ch_2, gamma_2····) <a href="#">↵</a>
Parameter		<p>out_1-4 / gamma_1-4: Output gamma 1 = 0.1 to 30 = 3.0 [Default] 10 = 1.0</p> <p>ch_1-4: Output channel 0 = All outputs, 1 = OUT1 to 4 = OUT4</p>
Getting example	Command	@GGM <a href="#">↵</a>
	Response	@GGM,22,10,10,10 <a href="#">↵</a>
	Description	Getting the set output gamma. OUT1: 2.2, Others: 1.0
Setting example	Command	@SGM,1,22 <a href="#">↵</a>
	Response	@SGM,1,22 <a href="#">↵</a>
	Description	Setting the OUT1 output gamma to 2.2.
Remarks		—

<b>@ODC</b>		<b>Output default color</b>
Setting	Command	@ODC, ch_1 (, ch_2···) ↵
	Response	@ODC, ch_1 (, ch_2···) ↵
Parameter		ch_1-4: Output channel 0 = All outputs, 1 = OUT1 to 4 = OUT4
Setting example	Command	@ODC,1 ↵
	Response	@ODC,1 ↵
	Description	Initializing OUT1 image quality settings. <b>@GOB / @SOB Output brightness</b> <b>@GOC / @SOC Output contrast</b> <b>@GGM / @SGM Output gamma</b>
Remarks		—

### 3.3.7 Input settings

<b>@GDT / @SDT</b>		<b>No-signal-input monitoring</b>
Getting	Command	@GDT ↵
	Response	@GDT, time_1, time_2, time_3, time_4, ···, time_8 ↵
Setting	Command	@SDT, ch_1, time_1 (, ch_2, time_2···) ↵
	Response	@SDT, ch_1, time_1 (, ch_2, time_2···) ↵
Parameter		time_1-8: No-signal-input monitoring 0 = OFF, 2000 = 2 sec to 15000 = 15 sec [Default] 10000 = 10 sec Set the value by 100 ms. If you set a value other than 0 for the lower 2 digits, these values will be rounded down. (For example, if you set it to 2955, the monitoring time is set to 2900 ms.) ch_1-8: Input channel 0 = All digital inputs, 1 = IN1 to 8 = IN8
Getting example	Command	@GDT ↵
	Response	@GDT,6000,10000,10000,4000,4000,4000,4000,4000 ↵
Setting example	Command	@SDT,3,6000 ↵
	Response	@SDT,3,6000 ↵
Remarks		Getting the set monitoring time of input video signal. IN1: 6000 ms. (6 sec.), IN2 and IN3: 10000 ms. (10 sec.), IN4 and IN8: 4000 ms. (4 sec.) Setting the monitoring time of IN3 to 6000 ms. (6 sec.) These commands are only for digital input. IN7 and IN8 are available only if "1" (Digital signal) is selected for " <b>@GIN / @SIN Signal selection of DVI input connector</b> ". If "0" (Analog signal) is selected, "-1" is returned.

<b>@GHE / @SHE</b>		<b>HDCP input enabled/disabled</b>
Getting	Command	@GHE
	Response	@GHE, hdcp_1, hdcp_2, hdcp_3, hdcp_4, ..., hdcp_8
Setting	Command	@SHE, ch_1, hdcp_1 (, ch_2, hdcp_2...)
	Response	@SHE, ch_1, hdcp_1 (, ch_2, hdcp_2...)
Parameter		hdcp_1-8 : HDCP input enabled/disabled 0 = DISABLE, 1 = ENABLE [Default] ENABLE
		ch_1-8: Input channel 0 = All digital inputs, 1 = IN1 to 8 = IN8
Getting example	Command	@GHE
	Response	@GHE,1,1,0,1,1,1,1,1
	Description	Getting HDCP input enabled/disabled. IN3: disables HDCP input, other input channels: enables HDCP input
Setting example	Command	@SHE,1,0
	Response	@SHE,1,0
	Description	Setting IN1 HDCP input to be disabled.
Remarks		These commands are only for digital input. IN7 and IN8 are available only if "1" (Digital signal) is selected for " <b>@GIN / @SIN Signal selection of DVI input connector</b> ". If "0" (Analog signal) is selected, "-1" is returned.

<b>@GAI / @SAI</b>		<b>Analog input type</b>
Getting	Command	@GAI
	Response	@GAI, type_1, type_2
Setting	Command	@SAI, ch_1, type_1 (, ch_2, type_2)
	Response	@SAI, ch_1, type_1 (, ch_2, type_2)
Parameter		type_1-2: Signal type 0 = AUTO [Default], 1 = RGB, 2 = YPbPr
		ch_1-2: Input channel 0 = All analog inputs, 7 = IN7, 8 = IN8
Getting example	Command	@GAI
	Response	@GAI,0,2
	Description	Getting signal type of analog input. IN7: AUTO, IN8: YPbPr
Setting example	Command	@SAI,0,2
	Response	@SAI,0,2
	Description	Setting the signal type of IN7 and IN8 to YPbPr.
Remarks		These commands are only for analog input. IN7 and IN8 are available only if "0" (Analog signal) is selected for " <b>@GIN / @SIN Signal selection of DVI input connector</b> ". If "1" (Digital signal) is selected, "-1" is returned.

<b>@GID / @SID</b>		<b>Automatic detection of input video interruption</b>
Getting	Command	@GID ↵
	Response	@GID, detect_1, detect_2, detect_3, detect_4, ..., detect_8 ↵
Setting	Command	@SID, ch_1, detect_1 (, ch_2, detect_2...) ↵
	Response	@SID, ch_1, detect_1 (, ch_2, detect_2...) ↵
Parameter		detect_1-8: Automatic detection 0 = OFF, 1 = ON [Default]
		ch_1-8: Input channel 0 = All inputs, 1 = IN1 to 8 = IN8
Getting example	Command	@GID ↵
	Response	@GID,1,1,1,1,1,0,1,1 ↵
	Description	Getting the setting of automatic detection of input video interruption. IN6: If input video signal is interrupted, the video output is not turned off instantly. Other inputs: OFF
Setting example	Command	@SID,2,0 ↵
	Response	@SID,2,0 ↵
	Description	Setting IN2 automatic detection to OFF ("0"). If input video signal is interrupted, not to turn off the video output instantly.
Remarks		—

<b>@GIN / @SIN</b>		<b>Signal selection of DVI input connector</b>
Getting	Command	@GIN ↵
	Response	@GIN, signal_1, signal_2 ↵
Setting	Command	@SIN, ch_1, signal_1 (, ch_2, signal_2) ↵
	Response	@SIN, ch_1, signal_1 (, ch_2, signal_2) ↵
Parameter		signal_1-2: Signal selection of DVI input connectors (IN7, IN8) 0 = Analog signal, 1 = Digital signal [Default]
		ch_1-2: Input channel 0 =All analog inputs, 7 = IN7, 8 = IN8
Getting example	Command	@GIN ↵
	Response	@GIN,0,0 ↵
	Description	Getting the set DVI input signal. IN7 and IN8: Analog input signal
Setting example	Command	@SIN,8,1 ↵
	Response	@SIN,8,1 ↵
	Description	Setting IN8 to digital input signal.
Remarks		—

@GIA / @SIA		HDBaseT input long reach mode
Getting	Command	@GIA, ch <input type="checkbox"/>
	Response	@GIA, ch, mode <input type="checkbox"/>
Setting	Command	@SIA, ch, mode <input type="checkbox"/>
	Response	@SIA, ch, mode <input type="checkbox"/>
Parameter		ch: Input channel 5 = IN5, 6 = IN6 Make sure to set this menu to "5" or "6".
		mode: Setting mode 0 = long reach mode OFF [Default], 1 = long reach mode ON
Getting example	Command	@GIA,5 <input type="checkbox"/>
	Response	@GIA,5,0 <input type="checkbox"/>
	Description	Getting long reach mode setting of IN5. Setting long reach mode of IN5 to OFF.
Setting example	Command	@SIA,6,1 <input type="checkbox"/>
	Response	@SIA,6,1 <input type="checkbox"/>
	Description	Setting long reach mode of IN6 to ON.
Remarks		If this menu is set to "ON", resolutions up to 1080p (24 bit) are supported. If it exceeds 1080p (24 bit), video signal cannot be received.

<b>@GFX / @SFX</b>		<b>Fixing settings for input signal</b>
Getting	Command	@GFX ch
	Response	@GFX, ch, mode (, aspect, analog, audio)
Setting	Command	@SFX, ch, mode (, aspect, analog, audio)
	Response	@SFX, ch, mode (, aspect, analog, audio)
Parameter		<p>ch: Input channel 1 = IN1 to 8 = IN8</p> <p>mode : Setting mode 0 = SELECTED, 1 = ALL FIXED</p> <p>Available only if the "mode" is selected to "0" (SELECTED)</p> <p>aspect: Aspect ratio 0 = OFF [Default], 1 = ON(FIXED)</p> <p>analog: Signal type of analog input (For digital input, select "0") 0 = OFF, 1 = ON(FIXED) [Default]</p> <p>audi : Audio input level (For analog input, select "0") 0 = OFF, 1 = ON(FIXED) [Default]</p>
Getting example	Command	@GFX, 1
	Response	@GFX, 1,0,1,0,0
	Description	<p>Getting setting fixation of each input signal. (For analog inputs) IN1 aspect ratio: current setting, signal type of analog input: setting of each input signal. Audio input level is disabled.</p>
Setting example	Command	@SFX,2,1
	Response	@SFX,2,1
	Description	<p>IN2: Fixing settings for each input to the current settings. Completed normally.</p>
Remarks		<p>When digital input channel is acquired, "0" is returned for the Parameter of analog signal type. ("0" is an invalid value.)</p> <p>When analog input channel is acquired, "0" is returned for the Parameter of audio input level. ("0" is an invalid value.)</p> <p>Input channels IN7 and IN8: digital input/analog input selectable. 【See: @GIN / @SIN Signal selection of DVI input connector】</p>

### 3.3.8 Input timing

@AIS / @AIT		Automatic measurement
Setting	Description	Starting automatic measurement of the start position and display period.
	Command	@AIS, ch ↵
	Response	@AIS, ch ↵
Setting	Description	Starting automatic measurement with a desired aspect ratio.
	Command	@AIT, ch (, mode) ↵
	Response	@AIT, ch (, mode) ↵
Parameter		<p>ch: Input channel 7 = IN7, 8 = IN8</p> <p>mode: Measurement mode -1 = NEXT ASPECT, 0 = 4:3, 1 = 5:4, 2 = 5:3, 3 = 16:9, 4 = 16:10</p> <p>If you select "NEXT ASPECT", the next aspect ratio will be selected in order every time the automatic measurement is executed. If you do not set any mode parameter, "NEXT ASPECT" mode will be applied.</p>
Setting example	Command	@AIS,8 ↵
	Response	@AIS,8 ↵
	Description	Starting the automatic measurement of IN8 the start position and display period.
Setting example	Command	@AIT,8,0 ↵
	Response	@AIT,8,0 ↵
	Description	Starting the automatic measurement of IN8 input timing setting at the aspect ratio of "4:3".
Setting example	Command	@AIS,8 ↵
	Response	@ERR,7 ↵
	Description	If the automatic measurement fails, an error is returned.
Remarks		These commands are valid only if analog RGB/analog YPbPr signal is input.

<b>@GHT / @SHT</b>		<b>The total number of horizontal dots</b>
Getting	Command	@GHT ↵
	Response	@GHT, h_total_1, h_total_2, h_total_3, h_total_4, ..., h_total_8 ↵
Setting	Command	@SHT, ch, h_total ↵
	Response	@SHT, ch, h_total ↵
Parameter		h_total_1-8 / h_total: The total number of horizontal dots 400 to 4125 (sampling block should be 13 MHz to 162 MHz) [Default] depends on input signal
		ch: Input channel 0 =All analog inputs, 7 = IN7, 8 = IN8
Getting example	Command	@GHT ↵
	Response	@GHT,2200,2200,0,2640,1344,1792,0,0 ↵
	Description	Getting the total number of horizontal dots. "0" is returned to channels without input signal.
Setting example	Command	@SHT,8,1344 ↵
	Response	@SHT,8,1344 ↵
	Description	Setting the total number of IN8 horizontal dots to "1344".
Setting example	Command	@SHT,8,1344 ↵
	Response	@ERR,3 ↵
	Description	If analog RGB signal or analog YPbPr signal is not input, an error is returned.
Remarks		Getting command acquires all channels' statuses. Setting commands are valid only if analog RGB/analog YPbPr signal is input.

<b>@GHS / @SHS</b>		<b>Horizontal start position</b>
Getting	Command	@GHS
	Response	@GHS, h_start_1, h_start_2, h_start_3, h_start_4, ..., h_start_8
Setting	Command	@SHS, ch, h_start
	Response	@SHS, ch, h_start
Parameter		h_start_1-8 / h_start : Horizontal start position 64 to 2900 (should be [the total number of horizontal dots – horizontal display period] or less) [Default] depends on input signal
		ch: Input channel 0 = All inputs, 1 = IN1 to 8 = IN8
Getting example	Command	@GHS
	Response	@GHS,192,192,496,0,296,0,378,0
	Description	Getting the horizontal start position. “0” is returned to channels without input signal.
Setting example	Command	@SHS,5,296
	Response	@SHS,5,296
	Description	Setting IN5 horizontal start position to 296 dots.
Setting example	Command	@SHS,6,296
	Response	@ERR,3
	Description	If no signal is input, an error is returned.
Remarks		Setting command is valid only for video signal except for 4K video signal. If 4K video signal is input, only Getting commands are available.

<b>@GHD / @SHD</b>		<b>Horizontal display period</b>
Getting	Command	@GHD
	Response	@GHD, h_disp_1, h_disp_2, h_disp_3, h_disp_4, ..., h_disp_8
Setting	Command	@SHD, ch, h_disp
	Response	@SHD, ch, h_disp
Parameter		h_disp_1-8 / h_disp : Horizontal display period 64 to 2900 (should be [the total number of horizontal dots - 64] or less) [Default] depends on input signal
		ch: Input channel 0 = All inputs, 1 = IN1 to 8 = IN8
Getting example	Command	@GHD
	Response	@GHD,1920,1920,0,1920,1024,1360,0,0
	Description	Getting horizontal display period. “0” is returned to channels without input signal.
Setting example	Command	@SHD,5,1024
	Response	@SHD,5,1024
	Description	Setting IN5 horizontal display period to 1024 dots.
Setting example	Command	@SHD,6,1024
	Response	@ERR,3
	Description	If no signal is input, an error is returned.
Remarks		Setting commands: valid only for video signal except for 4K video signal. If 4K video signal is input, only getting commands are valid.

<b>@GVS / @SVS</b>		<b>Vertical start position</b>
Getting	Command	@GVS
	Response	@GVS, v_start_1, v_start_2, v_start_3, v_start_4, ..., v_start_8
Setting	Command	@SVS, ch, v_start
	Response	@SVS, ch, v_start
Parameter		v_start_1-8 / v_start : Vertical start position 10 to 2048 (should be [the total number of vertical lines - vertical display period] or less) [Default] depends on input signal
		ch: Input channel 0 = All inputs, 1 = IN1 to 8 = IN8
Getting example	Command	@GVS
	Response	@GVS,40,0,40,40,35,0,24,0
	Description	Getting the vertical start position. "0" is returned to channels without input signal.
Setting example	Command	@SVS,5,35
	Response	@SVS,5,35
	Description	Setting IN5 vertical start position to 35 lines.
Setting example	Command	@SVS,6,35
	Response	@ERR,3
	Description	If no signal is input, an error is returned.
Remarks		Setting commands: valid only for video signal except for 4K video signal. If 4K video signal is input, only getting commands are valid.

<b>@GVD / @SVD</b>		<b>Vertical display period</b>
Getting	Command	@GVD
	Response	@GVD, v_disp_1, v_disp_2, v_disp_3, v_disp_4, ..., v_disp_8
Setting	Command	@SVD, ch, v_disp
	Response	@SVD, ch, v_disp
Parameter		v_disp_1-8 / v_disp: Vertical display period 10 to 2048 (should be [the total number of vertical lines - 10] or less) [Default] depends on input signal
		ch: Input channel 0 = All inputs, 1 = IN1 to 8 = IN8
Getting example	Command	@GVD
	Response	@GVD,0,1080,1080,900,768,0,900,0
	Description	Getting vertical display period. "0" is returned to channels without input signal.
Setting example	Command	@SVD,5,768
	Response	@SVD,5,768
	Description	Setting IN5 vertical display period to 768 lines.
Setting example	Command	@SVD,5,768
	Response	@ERR,3
	Description	If no signal is input, an error is returned.
Remarks		Setting commands: valid only for video signal except for 4K video signal. If 4K video signal is input, only getting commands are valid.

<b>@GIS / @SIS</b>		<b>Automatic measurement of start position</b>
Getting	Command	@GIS ↵
	Response	@GIS, mode_1, mode_2 ↵
Setting	Command	@SIS, ch, mode ↵
	Response	@SIS, ch, mode ↵
Parameter		mode_1-2 / mode: Automatic measurement 0 = All inputs from this input channel are not measured automatically. 1 = Current input signal is not measured automatically. 2 = Current input signal is measured automatically. [Default]
		ch: Input channel 0 = All analog inputs, 7 = IN7, 8 = IN8
Getting example	Command	@GIS ↵
	Response	@GIS,0,2 ↵
	Description	Getting the setting of Automatic measurement of the start position. IN7: not measured automatically, IN8: measured automatically.
Setting example	Command	@SIS,8,1 ↵
	Response	@SIS,8,1 ↵
	Description	Setting signal that is currently input from IN8 to "1" (Current input signal is not measured automatically).
Remarks		These commands are only for analog input. IN7 and IN8 are available only if "0" (Analog signal) is selected for " <b>@GIN / @SIN Signal selection of DVI input connector</b> ". If "1" (Digital signal) is selected, "-1" is returned.

<b>@GSM / @SSM</b>		<b>Automatic measurement when unregistered signal is input</b>
Getting	Command	@GSM ↵
	Response	@GSM, mode ↵
Setting	Command	@SSM, mode ↵
	Response	@SSM, mode ↵
Parameter		mode: Automatic measurement 0 = Not execute, 1 = Execute [Default]
Getting example	Command	@GSM ↵
	Response	@GSM,1 ↵
	Description	Getting the set automatic measurement mode when unregistered signal is input. Automatic measurement is set to "1" (Execute).
Setting example	Command	@SSM,1 ↵
	Response	@SSM,1 ↵
	Description	Setting the automatic measurement to be executed when unregistered signal is input.
Remarks		—

<b>@RTT</b>		<b>Loading device data</b>
Setting	Command	@RTT, ch (, table) ↵
	Response	@RTT, ch (, table) ↵
Parameter		<p>ch: Input channel 1 = IN1 to 8 = IN8</p> <p>table: Device table 1 to 99 (Registered device data), 100 to 100+n (Preset device data. "n" varies depending on input signal, but 0 for most cases.)</p> <p>Only for analog input, specify the device table.</p>
Setting example	Command	@RTT,1 ↵
	Response	@RTT,1 ↵
	Description	Reconfiguring IN1 input timing setting to the value detected automatically.
Setting example	Command	@RTT,6,2 ↵
	Response	@RTT,6,2 ↵
	Description	Setting IN6 input timings to the values saved in the device table 2.
Remarks		<p>This command is valid only if signal is input.</p> <p>For analog input, this command is valid only if the device data of input signal is registered.</p>

<b>@STT</b>		<b>Registering device data</b>
Setting	Command	@STT, ch, table (, name) ↵
	Response	@STT, ch, table (, name) ↵
Parameter		<p>ch: Input channel 1 = IN1, 2 = IN2</p> <p>table: Device table 1 to 99</p> <p>name: Device table name Up to 14 characters from 20 to 7D of ASCII code.</p> <p>You can skip "Device table name". If you skip it, only input timing setting is saved. However, if no device table name is currently saved, the resolution is saved automatically as the device table name.</p>
Setting example	Command	@STT,1,2 ↵
	Response	@STT,1,2 ↵
	Description	Saving IN1 input timing setting in device table 2 without editing the device table name.
Setting example	Command	@STT,1,2,XGA 60Hz ↵
	Response	@STT,1,2,XGA 60Hz ↵
	Description	Saving the current IN8 input timing setting in device table 2 with the name of "XGA 60Hz".
Remarks		This command is valid only if analog RGB / YPbPr signal is input.

@GTK / @STK		Tracking
Getting	Command	@GTK ↵
	Response	@GTK, track_1, track_2 ↵
Setting	Command	@STK, ch_1, track_1 (, ch_2 , track_2) ↵
	Response	@STK, ch_1, track_1 (, ch_2 , track_2) ↵
Parameter		track_1-2: Tracking 0 to 63 [Default] 0
		ch_1-2: Input channel 0 = All analog inputs, 7 = IN7, 8 = IN8
Getting example	Command	@GTK ↵
	Response	@GTK,4,0 ↵
	Description	Getting the set tracking. If no analog RGB / YPbPr signal is input, "0" is returned.
Setting example	Command	@STK,8,4 ↵
	Response	@STK,8,4 ↵
	Description	Setting IN8 tracking to "4".
Remarks		This command is valid only if analog RGB / YPbPr signal is input. If "1" (Digital signal) is selected, "-1" is returned.

### 3.3.9 Output settings

@GEQ / @SEQ		Output equalizer
Getting	Command	@GEQ
	Response	@GEQ, level_1, level_2, level_3, level_4
Setting	Command	@SEQ, ch_1, level_1 (, ch_2, level_2···)
	Response	@SEQ, ch_1, level_1 (, ch_2, level_2···)
Parameter		level_1-4: Output mode 0 = OFF [Default], 1 = LOW, 2 = MIDDLE, 3 = HIGH  ch_1-4: Output channel 0 = All HDMI outputs, 1 = OUT1A to 4 = OUT4A
Getting example	Command	@GEQ
	Response	@GEQ,3,0,3,3
	Description	Getting the set output mode. OUT2A: OFF, other output channels: HIGH
Setting example	Command	@SEQ,1,0
	Response	@SEQ,1,0
	Description	Setting the OUT1A output equalizer to OFF.
Remarks		This command is only for HDMI output connectors.

@GDM / @SDM		Output mode
Getting	Command	@GDM
	Response	@GDM, mode_1, mode_2, mode_3, mode_4
Setting	Command	@SDM, ch_1, mode_1 (, ch_2, mode_2···)
	Response	@SDM, ch_1, mode_1 (, ch_2, mode_2···)
Parameter		mode_1-4: Output mode 0 = DVI MODE, 1 = HDMI RGB MODE, 2 = HDMI YCbCr4:2:2 MODE, 3 = HDMI YCbCr4:4:4 MODE [Default]  ch_1-4: Output channel 0 = All outputs, 1 = OUT1 to 4 = OUT4
Getting example	Command	@GDM
	Response	@GDM,3,0,3,3
	Description	Getting the set output mode. OUT2: DVI MODE, other output channels: HDMI YCbCr4:4:4 MODE
Setting example	Command	@SDM,1,3
	Response	@SDM,1,3
	Description	Setting the OUT1 output mode to "HDMI YCbCr4: 4: 4 MODE"
Remarks		—

<b>@GUY / @SUY</b>		<b>Synchronous signal output when no video signal is input</b>
Getting	Command	@GUY [↵]
	Response	@GUY, sync_1, sync_2, sync_3, sync_4 [↵]
Setting	Command	@SUY, ch_1, sync_1 (, ch_2, sync_2···) [↵]
	Response	@SUY, ch_1, sync_1 (, ch_2, sync_2···) [↵]
Parameter		sync_1-4: Synchronous signal output 0 = Not output, 1 = Output [Default]
		ch_1-4: Output channel 0 = All outputs, 1 = OUT1 to 4 = OUT4
Getting example	Command	@GUY [↵]
	Response	@GUY,1,0,0,0 [↵]
	Description	Getting synchronous signal output when no video signal is input. OUT1: synchronous signal is output. Other output channels: synchronous signal is not output.
Setting example	Command	@SUY,1,1 [↵]
	Response	@SUY,1,1 [↵]
	Description	Setting OUT1 to "1" (synchronous signal is output even if video signal is not input).
Remarks		—

<b>@GBO / @SBO</b>		<b>Output video when no video signal is not input</b>
Getting	Command	@GBO [↵]
	Response	@GBO, video_1, video_2, video_3, video_4 [↵]
Setting	Command	@SBO, ch_1, video_1 (, ch_2, video_2···) [↵]
	Response	@SBO, ch_1, video_1 (, ch_2, video_2···) [↵]
Parameter		video_1-4: Output video when no video signal is not input 0 = Black, 1 = Blue [Default], 2 = Background color
		ch_1-4: Output channel 0 = All outputs, 1 = OUT1 to 4 = OUT4
Getting example	Command	@GBO [↵]
	Response	@GBO,1,0,0,0 [↵]
	Description	Getting the output video when no video signal is input. OUT1: blue screen, other output channels: black screen
Setting example	Command	@SBO,1,1 [↵]
	Response	@SBO,1,1 [↵]
	Description	Setting OUT1 to output blue when no video signal is input.
Remarks		—

<b>@GFF / @SFF</b>		<b>Video switching effect</b>
Getting	Command	@GFF ↵
	Response	@GFF, switching_1, switching_2, switching_3, switching_4 ↵
Setting	Command	@SFF, ch_1, switching_1 (, ch_2, switching_2···) ↵
	Response	@SFF, ch_1, switching_1 (, ch_2, switching_2···) ↵
Parameter		switching_1-4: Video switching effect 0 = CUT, 1 = FADE OUT/IN, 2 = FREEZE + FADE OUT/IN [Default], 3 = LEFT→RIGHT WIPE, 4 = RIGHT→LEFT WIPE, 5 = TOP→BOTTOM WIPE, 6 = BOTTOM→TOP WIPE
		ch_1-4: Output channel 0 = All outputs, 1 = OUT1 to 4 = OUT4
Getting example	Command	@GFF ↵
	Response	@GFF,0,0,1,1 ↵
	Description	Getting input channel switching effect. OUT1 and OUT2: CUT, OUT3 and OUT4: FADE OUT/IN
Setting example	Command	@SFF,1,1 ↵
	Response	@SFF,1,1 ↵
	Description	Setting OUT1 switching effect to FADE OUT/IN.
Remarks		An error occurs if this menu is set to one of "3" to "6" (WIPE) while video combination mode is enabled.

<b>@GFT / @SFT</b>		<b>Video switching speed</b>
Getting	Command	@GFT ↵
	Response	@GFT, time_1, time_2, time_3, time_4 ↵
Setting	Command	@SFT, ch_1, time_1 (, ch_2, time_2···) ↵
	Response	@SFT, ch_1, time_1 (, ch_2, time_2···) ↵
Parameter		time_1-4: Switching speed 100 = 0.1 sec. to 2000 = 2 sec. [Default] 350 = 0.35 sec. Set the value by 10 ms. If you set a value other than 0 for the lower 1 digits, these values will be rounded down. (For example, if you set it to 395, the speed is set to 390 ms.)
		ch_1-4: Output channel 0 = All outputs, 1 = OUT1 to 4 = OUT4
Getting example	Command	@GFT ↵
	Response	@GFT,400,400,350,350 ↵
	Description	Getting the set switching speed of video input channel. OUT1 and OUT2: 400 ms, OUT3 and OUT4: 350 ms
Setting example	Command	@SFT,1,400 ↵
	Response	@SFT,1,400 ↵
	Description	Setting OUT1 switching time to 400 ms.
Remarks		—

<b>@GWC / @SWC</b>		<b>Wipe color</b>
Getting	Command	@GWC, ch <input type="checkbox"/>
	Response	@GWC, ch, red, green, blue <input type="checkbox"/>
Setting	Command	@SWC, ch_1, red_1, green_1, blue_1 (, ch_2, red_2, green_2, blue_2···) <input type="checkbox"/>
	Response	@SWC, ch_1, red_1, green_1, blue_1 (, ch_2, red_2, green_2, blue_2···) <input type="checkbox"/>
Parameter		<p>ch: Output channel 1 = OUT1 to 4 = OUT4</p> <p>ch_1-4: Output channel 0 = All outputs, 1 = OUT1 to 4 = OUT4</p> <p>red / red_1-4 : Wipe color (Red) green / green_1-4 : Wipe color (Green) blue / blue_1-4 : Wipe color (Blue) 0 to 255 [Default] 0 (black)</p>
Getting example	Command	@GWC,1 <input type="checkbox"/>
	Response	@GWC,1,255,255,255 <input type="checkbox"/>
	Description	Getting the set wipe color of OUT1. RGB: 255 (white)
Setting example	Command	@SWC,1,255,255,255 <input type="checkbox"/>
	Response	@SWC,1,255,255,255 <input type="checkbox"/>
	Description	Setting the wipe colors (RGB) of OUT1 to "255" (white).
Remarks		—

@GVO / @SVO		HDMI / HDBaseT output
Getting	Command	@GVO ↵
	Response	@GVO, out_1A, out_1B, out_2A, out2B, ..., out_4A, out_4B ↵
Setting	Command	@SVO, ch_1, out_1A, out_1B (, ch_2, out_2A, out_2B···) ↵
	Response	@SVO, ch_1, out_1A, out_1B (, ch_2, out_2A, out_2B···) ↵
Parameter		<p>out_1A-4A: HDMI (OUT A) output video  out_1B-4B: HDBaseT (OUT B) output video  0 = Not output, 1 = Output  [Default]: HDMI output signal is output from HDMI output connector,  HDBaseT signal is not output from HDBaseT output connector  (All output channels)</p> <p>* The MSD cannot output signals from HDMI connector and HDBaseT connector simultaneously. Ensure to set only one connector to output signal</p>
		<p>ch_1-4: Output channel  0 = All outputs, 1 = OUT1 to 4 = OUT4</p>
Getting example	Command	@GVO ↵
	Response	@GVO,1,0,1,0,0,1,0,1 ↵
	Description	<p>Getting the video output connectors.  OUT1 and OUT2: The HDMI output connectors output video while the HDBaseT output connectors do not output video.  OUT3 and OUT4: The HDMI output connectors do not output video while the HDBaseT output connectors output video.</p>
Setting example	Command	@SVO,1,1,0 ↵
	Response	@SVO,1,1,0 ↵
	Description	<p>Setting video output connector.  OUT1: The HDMI output connector outputs video and the HDBaseT output connector does not output video.</p>
Remarks		An error occurs if the same parameter is issued to both HDMI output connector and HDBaseT output connector.

<b>@GEN / @SEN</b>		<b>HDCP output</b>
Getting	Command	@GEN
	Response	@GEN, hdcp_1, hdcp_2, hdcp_3, hdcp_4
Setting	Command	@SEN, ch_1, hdcp_1 (, ch_2, hdcp_2····)
	Response	@SEN, ch_1, hdcp_1 (, ch_2, hdcp_2····)
Parameter		hdcp_1-4: HDCP output 0 = HDCP is encrypted only if input signal is with HDCP, 1 = HDCP is always encrypted. [Default], 2 = HDCP is not encrypted.
		ch_1-4: Output channel 0 = All outputs, 1 = OUT1 to 4 = OUT4
Getting example	Command	@GEN
	Response	@GEN,1,1,1,0
	Description	Getting the set HDCP output. OUT4: HDCP is encrypted only if input signal is with HDCP. Other output channels: HDCP is always encrypted.
Setting example	Command	@SEN,1,1
	Response	@SEN,1,1
	Description	Setting OUT1 to "1" (HDCP is always encrypted).
Remarks		—

<b>@GHR / @SHR</b>		<b>The number of HDCP retries</b>
Getting	Command	@GHR
	Response	@GHR, retry_1, retry_2, retry_3, retry_4
Setting	Command	@SHR, ch_1, retry_1 (, ch_2, retry_2····)
	Response	@SHR, ch_1, retry_1 (, ch_2, retry_2····)
Parameter		retry_1-4: The number of retries -1 = Retry until succeed [Default], 0 = Not retry, 1 to 100 = Retry for the desired number of retries
		ch_1-4: Output channel 0 = All outputs, 1 = OUT1 to 4 = OUT4
Getting example	Command	@GHR
	Response	@GHR,-1,-1,-1,10
	Description	Getting the set number of HDCP retries. OUT4: Retry for up to 10 times. Other output channels: continue to retry until succeed.
Setting example	Command	@SHR,4,10
	Response	@SHR,4,10
	Description	Setting OUT4 to retry for up to 10 times.
Remarks		—

<b>@GDC / @SDC</b>		<b>Deep Color</b>
Getting	Command	@GDC
	Response	@GDC, color_1, color_2, color_3, color_4
Setting	Command	@SDC, ch_1, color_1 (, ch_2, color_2····)
	Response	@SDC, ch_1, color_1 (, ch_2, color_2····)
Parameter		color_1-4: Color depth 0 = 24-BIT COLOR [Default], 1 = 30-BIT COLOR
		ch_1-4: Output channel 0 = All outputs, 1 = OUT1 to 4 = OUT4
Getting example	Command	@GDC
	Response	@GDC,1,1,0,1,1,1,1
	Description	Getting the set color depth. OUT3: 24-BIT COLOR, Other output channels: 30-BIT COLOR
Setting example	Command	@SDC,1,0
	Response	@SDC,1,0
	Description	Setting OUT1 deep color to 24-BIT COLOR.
Remarks		—

<b>@GCE / @SCE</b>		<b>CEC connection</b>
Getting	Command	@GCE
	Response	@GCE, connect_1, connect_2, connect_3, connect_4
Setting	Command	@SCE, ch_1, connect_1 (, ch_2, connect_2····)
	Response	@SCE, ch_1, connect_1 (, ch_2, connect_2····)
Parameter		connect_1-4: CEC connection 0 = Not connected [Default], 1 = Selected video input channel, 2 = Input channel1, 3 = Input channel2, 4 = Input channel3, 5 = Input channel4, 6 = Input channel5, 7 = Input channel8
		ch_1-4: Output channel 0 = All outputs, 1 = OUT1 to 4 = OUT4
Getting example	Command	@GCE
	Response	@GCE,4,0,0,0
	Description	Getting the set CEC connection. OUT1: connecting to input channel3, Other output channels: not connected.
Setting example	Command	@SCE,1,4
	Response	@SCE,1,4
	Description	Setting OUT1 CEC connection to Input channel3.
Remarks		—

<b>@HAU</b>		<b>HDCP re-encryption</b>
Setting	Command	@HAU, ch_1 (, ch_2···) ↵
	Response	@HAU, ch_1 (, ch_2···) ↵
Parameter		ch_1-4: Output channel 0 = All outputs, 1 = OUT1 to 4 = OUT4
Setting example	Command	@HAU,1 ↵
	Response	@HAU,1 ↵
	Description	Setting OUT1 to re-encrypt HDCP.
Remarks		—

<b>@GAU / @SAU</b>		<b>Priority of input channel automatic switching (OFF to ON)</b>
Getting	Command	@GAU, out ↵
	Response	@GAU, out, in1_priority, in2_priority, in3_priority, in4_priority, ···, in8_priority ↵
Setting	Command	@SAU, out_1, in1_priority, in2_priority···, in8_priority (, out_2, in1_priority···) ↵
	Response	@SAU, out_1, in1_priority, in2_priority···, in8_priority (, out_2, in1_priority···) ↵
Parameter		out, out_1-4: Output channel 0 = All outputs, 1 = OUT1 to 4 = OUT4  in1_priority-in8_priority: Priority 0 = OFF, 1 = priority (high) to 8 = priority (low)
Getting example	Command	@GAU,1 ↵
	Response	@GAU,1,1,2,3,4,5,6,7,8 ↵
	Description	Getting the set priority of OUT1's automatic switching. IN1>IN2>···>IN8.
Setting example	Command	@SAU,1,8,7,6,5,4,3,2,1 ↵
	Response	@SAU,1,8,7,6,5,4,3,2,1 ↵
	Description	Setting the priority of OUT1's automatic switching to IN8>IN7>···>IN1.
Remarks		—

<b>@GOF / @SOF</b>		<b>Priority of input channel automatic switching (ON to OFF)</b>
Getting	Command	@GOF, out <input type="checkbox"/>
	Response	@GOF, out, in1_priority, in2_priority, in3_priority, in4_priority, ···, in8_priority <input type="checkbox"/>
Setting	Command	@SOF, out_1, in1_priority, in2_priority···, in8_priority (, out_2, in1_priority···) <input type="checkbox"/>
	Response	@SOF, out_1, in1_priority, in2_priority···, in8_priority (, out_2, in1_priority···) <input type="checkbox"/>
Parameter		out, out_1-4: Output channel 0 = All outputs, 1 = OUT1 to 4 = OUT4
		in1_priority-in8_priority: Priority 0 = OFF, 1 = priority (high) to 8 = priority (low)
Getting example	Command	@GOF,1 <input type="checkbox"/>
	Response	@GOF,1,1,2,3,4,5,6,7,8 <input type="checkbox"/>
	Description	Getting the set priority of OUT1's automatic switching. IN1>IN2>···>IN8
Setting example	Command	@SOF,1,8,7,6,5,4,3,2,1 <input type="checkbox"/>
	Response	@SOF,1,8,7,6,5,4,3,2,1 <input type="checkbox"/>
	Description	Setting the priority of OUT1's automatic switching to IN8>IN7>···>IN1.
Remarks		—

<b>@GMT / @SMT</b>		<b>Masking time after automatic switching of input channel</b>
Getting	Command	@GMT <input type="checkbox"/>
	Response	@GMT, time_1, time_2, time_3, time_4 <input type="checkbox"/>
Setting	Command	@SMT, ch_1, time_1 (, ch_2, time_2···) <input type="checkbox"/>
	Response	@SMT, ch_1, time_1 (, ch_2, time_2···) <input type="checkbox"/>
Parameter		time_1-4 : Masking time 0 = 0 sec. to 999999 = 999.999 sec. [Default] 0 sec.
		ch_1-4: Output channel 0 = All outputs, 1 = OUT1 to 4 = OUT4
Getting example	Command	@GMT <input type="checkbox"/>
	Response	@GMT,2000,2000,10000,10000 <input type="checkbox"/>
	Description	Getting the set masking time after automatic switching of input channel. OUT1 and OUT2: 2000 ms (2 sec.), OUT3 and OUT4: 10000 ms (10 sec.)
Setting example	Command	@SMT,1,2000,2,2000,3,10000,4,10000 <input type="checkbox"/>
	Response	@SMT,1,2000,2,2000,3,10000,4,10000 <input type="checkbox"/>
	Description	Setting the masking time to 2000 ms. (2 sec.) for OUT1 and OUT2, 10000 ms. (10 sec.) for OUT3 and OUT4.
Remarks		—

<b>@GAD / @SAD</b>		<b>Channel switching mode for input channel automatic switching</b>
Getting	Command	@GAD
	Response	@GAD, mode_1, mode_2, mode_3, mode_4
Setting	Command	@SAD, ch_1, mode_1 (, ch_2, mode_2···)
	Response	@SAD, ch_1, mode_1 (, ch_2, mode_2···)
Parameter		mode_1-4 : Channel switching mode 0 = VIDEO, 1 = AUDIO, 2 = V&A [Default]
		ch_1-4: Output channel 0 = All outputs, 1 = OUT1 to 4 = OUT4
Getting example	Command	@GAD
	Response	@GAD,2,2,1,1
	Description	Getting the set channel switching mode to: OUT1 and OUT2: V&A, OUT3 and OUT4: AUDIO
Setting example	Command	@SAD,1,2,2,2,3,0,4,0
	Response	@SAD,1,2,2,2,3,0,4,0
	Description	Setting the channel switching mode to: OUT1 and OUT2: V&A, OUT3 and OUT4: VIDEO
Remarks		—

<b>@GOA / @SOA</b>		<b>HDBaseT output long reach mode</b>
Getting	Command	@GOA, ch
	Response	@GOA, ch, mode
Setting	Command	@SOA, ch_1, mode_1 (, ch_2, mode_2···)
	Response	@SOA, ch_1, mode_1 (, ch_2, mode_2···)
Parameter		mode_1-4: Setting mode 0 = long reach mode OFF [Default], 1 = long reach mode ON
		ch_1-4: Output channel 0 = All outputs, 1 = OUT1B to 4 = OUT4B
Getting example	Command	@GOA,1
	Response	@GOA,1,0
	Description	Getting long reach mode setting of OUT1B. OUT1B: Long reach mode is set to OFF
Setting example	Command	@SOA,1,1
	Response	@SOA,1,1
	Description	Setting long reach mode of OUT1B to ON.
Remarks		If this menu is set to “ON”, resolutions up to 1080p (24 bit) are supported. If it exceeds 1080p (24 bit), signals cannot be received.

### 3.3.10 Audio

<b>@GSL / @SSL</b>		<b>Audio output level</b>
Getting	Command	@GSL
	Response	@GSL, level_1, level_2, level_3, level_4
Setting	Command	@SSL, ch_1, level_1 (, ch_2, level_2···)
	Response	@SSL, ch_1, level_1 (, ch_2, level_2···)
Parameter		level_1-4: Audio output level -60 to 10 [Default] 0
		ch_1-4: Output channel 0 = All outputs, 1 = OUT1 to 4 = OUT4
Getting example	Command	@GSL
	Response	@GSL,-4,-4,0,0
	Description	Getting the set audio output level. OUT1 and OUT2: -4 dB, OUT3 and OUT4: ±0 dB
Setting example	Command	@SSL,1,-4
	Response	@SSL,1,-4
	Description	Setting OUT1 audio output level to -4 dB.
Remarks		If you change the output level while muted, it will be unmuted.

<b>@SOL</b>		<b>Relative value of audio output level</b>
Setting	Command	@SOL, ch_1, updown_1 (, ch_2, updown_2···)
	Response	@SOL, ch_1, updown_1 (, ch_2, updown_2···)
Parameter		ch_1-4: Output channel 0 = All outputs, 1 = OUT1 to 4 = OUT4
		updown_1-4: Relative value setting -70 to 70
		The specified value is added to the current audio output level. If the total value exceeds the limit value (-60 to +10), the limit value will be applied.
Setting example	Command	@SOL,1,-1
	Response	@SOL,1,-1
	Description	Lower 1 dB of audio output level of OUT1.
Remarks		If you change the output level while muted, it will be unmuted.

<b>@GOL</b>		<b>Limit status of audio output level</b>
Getting	Command	@GOL ↵
	Response	@GOL, out_1, out_2, out_3, out_4 ↵
Parameter		out_1-4: Limit status of audio output level -1 = minimum settable value (-60 dB), 0 = not limit status, 1 = maximum settable value (+10 dB)
Getting example	Command	@GOL ↵
	Response	@GOL,1,1,0,0 ↵
	Description	Getting limit status of audio output level. OUT1 to OUT2: maximum settable value OUT3 to OUT4: not reach the limit value
Remarks		—

<b>@GAM / @SAM</b>		<b>Audio output mute</b>	
Getting	Command	@GAM ↵	
	Response	@GAM, mute_1, mute_2, mute_3, mute_4 ↵	
Setting	Command	@SAM, ch_1, mute_1 (, ch_2, mute_2···) ↵	
	Response	@SAM, ch_1, mute_1 (, ch_2, mute_2···) ↵	
Parameter		mute_1-4: Audio output mute 0 = Mute OFF [Default], 1 = Mute ON  ch_1-4: Output channel 0 = All outputs, 1 = OUT1 to 4 = OUT4	
Getting example	Command	@GAM ↵	
	Response	@GAM,1,1,0,0 ↵	
		Description	Getting the set value of audio output mute. OUT1 and OUT2: Mute ON, OUT3 and OUT4: Mute OFF
Setting example	Command	@SAM,1,1 ↵	
	Response	@SAM,1,1 ↵	
	Description	Muting OUT1 audio output.	
Remarks		—	

<b>@GAS / @SAS</b>		<b>Selecting audio input</b>
Getting	Command	@GAS ↵
	Response	@GAS, select_1, select_2, select_3, select_4, ..., select_8 ↵
Setting	Command	@SAS, ch_1, select_1 (, ch_2, select_2...) ↵
	Response	@SAS, ch_1, select_1 (, ch_2, select_2...) ↵
Parameter		select_1-8: Audio input selection 0 = Digital audio [Default], 1 = analog audio 1, 2 = analog audio 2
		ch_1-8: Input channel 0 = All digital inputs, 1 = IN1 to 8 = IN8
Getting example	Command	@GAS ↵
	Response	@GAS,1,0,0,0,0,0,0,0 ↵
	Description	Getting the set audio input selection. IN1: analog audio IN1 Other input channels: digital audio
Setting example	Command	@SAS,3,0 ↵
	Response	@SAS,3,0 ↵
	Description	Setting IN3 audio input to digital audio.
Remarks		—

<b>@GSO / @SSO</b>		<b>Aduio input level</b>
Getting	Command	@GSO
	Response	@GSO, level_1, level_2, level_3, level_4, ..., level_8
Setting	Command	@SSO, ch_1, level_1 (, ch_2, level_2····)
	Response	@SSO, ch_1, level_1 (, ch_2, level_2····)
Parameter		level_1-8: Audio input level -60 to 0 [Default] 0  ch_1-8: Input channel 0 = All inputs, 1 = IN1 to 8 = IN8
Getting example	Command	@GSO
	Response	@GSO,0,0,0,0,-4,0,0,0
	Description	Getting audio input level. IN5: -4 dB, other input channels: $\pm 0$ dB
Setting example	Command	@SSO,5,-8
	Response	@SSO,5,-8
	Description	Setting IN5 audio input level to -8 dB.
Remarks		—

<b>@SIL</b>		<b>Relative value of audio input level</b>
Setting	Command	@SIL, ch_1, updown_1 (, ch_2, updown_2····)
	Response	@SIL, ch_1, updown_1 (, ch_2, updown_2····)
Parameter		ch_1-8: Input channel 0 = All inputs, 1 = IN1 to 8 = IN8  updown_1-8: Setting relative value -60 to 60  The specified value is added to the current audio input level. If the total value exceeds the limit value (-60 to +0), the limit value will be applied.
Setting example	Command	@SIL,1,-1
	Response	@SIL,1,-1
	Description	Lowering IN1 audio input level (1 dB).
Remarks		—

<b>@GIL</b>		<b>Limit status of audio input level</b>
Getting	Command	@GIL
	Response	@GIL, in_1, in_2, in_3, in_4, ..., in_8
Parameter		in_1-8: Limit status -1 = minimum settable value (-60 dB), 0 = not limit status, 1 = maximum settable value ( $\pm 0$ dB)
Getting example	Command	@GIL
	Response	@GIL,1,0,0,0,0,0,0,0
Description		Getting the set limit status of audio input level. IN1: maximum settable value Other input channels: not limit value
Remarks		—

<b>@GLO / @SLO</b>		<b>Output lip sync</b>
Getting	Command	@GLO
	Response	@GLO, frame_1, frame_2, frame_3, frame_4
Setting	Command	@SLO, ch_1, frame_1 (, ch_2, frame_2···)
	Response	@SLO, ch_1, frame_1 (, ch_2, frame_2···)
Parameter		frame_1-4: Output lip sync 0 to 8 [Default] 0
		ch_1-4: Output channel 0 = All outputs, 1 = OUT1 to 4 = OUT4
Getting example	Command	@GLO
	Response	@GLO,0,0,2,2
	Description	Getting the set lip sync of the output side. OUT1 and OUT2: 0 frame, OUT3 and OUT4: 2 frames
Setting example	Command	@SLO,1,2
	Response	@SLO,1,2
	Description	Setting the OUT1 lip sync to 2 frames.
Remarks		—

<b>@GLY / @SLY</b>		<b>Input lip sync</b>
Getting	Command	@GLY
	Response	@GLY, frame_1, frame_2, frame_3, frame_4, ···, frame_8
Setting	Command	@SLY, ch_1, frame_1 (, ch_2, frame_2···)
	Response	@SLY, ch_1, frame_1 (, ch_2, frame_2···)
Parameter		frame_1-8: Input lip sync 0 to 8 [Default] 0
		ch_1-8: Input channel 0 = All inputs, 1 = IN1 to 8 = IN8
Getting example	Command	@GLY
	Response	@GLY,0,0,0,2,0,0,0,0
	Description	Getting the set lip sync of input side. IN4: 2 frames, other input channels: 0 frame
Setting example	Command	@SLY,4,2
	Response	@SLY,4,2
	Description	Setting the IN4 lip sync to 2 frames.
Remarks		—

<b>@GSF / @SSF</b>		<b>Sampling frequency</b>
Getting	Command	@GSF
	Response	@GSF, frequency_1, frequency_2, frequency_3, frequency_4
Setting	Command	@SSF, ch_1, frequency_1 (, ch_2, frequency_2···)
	Response	@SSF, ch_1, frequency_1 (, ch_2, frequency_2···)
Parameter		frequency_1-4: Sampling frequency 0 = AUTO [Default], 1 = 32 kHz, 2 = 44.1 kHz, 3 = 48 kHz, 4 = 88.2 kHz, 5 = 96 kHz, 6 = 192 kHz
		ch_1-4: Output channel 0 = All outputs, 1 = OUT1 to 4 = OUT4
Getting example	Command	@GSF
	Response	@GSF,0,0,2,2
	Description	Getting sampling frequency settings. OUT1 and OUT2: AUTO, OUT3 and OUT4: 32 kHz
Setting example	Command	@SSF,1,3
	Response	@SSF,1,3
	Description	Setting OUT1 sampling frequency to 48 kHz.
Remarks		—

<b>@GFD</b>		<b>Actual sampling frequency</b>
Getting	Command	@GFD
	Response	@GFD, frequency_1, frequency_2, frequency_3, frequency_4
Parameter		frequency_1-4: Sampling frequency 1 = 32 kHz, 2 = 44.1 kHz, 3 = 48 kHz, 4 = 88.2 kHz, 5 = 96 kHz, 6 = 192 kHz
Getting example	Command	@GFD
	Response	@GFD,5,5,3,3
	Description	Getting the actual sampling frequency. OUT1 and OUT2: 96 kHz, OUT3 and OUT4: 48 kHz
Remarks		“@GSF / @SSF Sampling frequency” is set to “AUTO”, the sampling frequency that is output actually is returned. If it is set to value other than “AUTO”, the set sampling frequency is returned.

<b>@GCS / @SCS</b>		<b>Analog audio output</b>
Getting	Command	@GCS ↵
	Response	@GCS, channel ↵
Setting	Command	@SCS, channel ↵
	Response	@SCS, channel ↵
Parameter		channel: Output channel 1 = OUT1 [Default] to 4 = OUT4
Getting example	Command	@GCS ↵
	Response	@GCS,2 ↵
	Description	Getting the analog audio output setting. Distributing audio from the OUT2.
Setting example	Command	@SCS,1 ↵
	Response	@SCS,1 ↵
	Description	Setting the analog audio output to OUT 1.
Remarks		—







<b>@GMD / @SMD</b>		<b>Multi channel audio output</b>
Getting	Command	@GMD ↵
	Response	@GMD, out_1, out_2, out_3, out_4 ↵
Setting	Command	@SMD, ch_1, out_1 (, ch_2, out_2····) ↵
	Response	@SMD, ch_1, out_1 (, ch_2, out_2····) ↵
Parameter		out_1-4: Multi channel audio output 0 = CH1 / CH2 STEREO, 1 = CH3 / CH4 STEREO, 2 = CH5 / CH6 STEREO, 3 = CH7 / CH8 STEREO, 4 = CH1 / CH2 MONO, 5 = CH3 / CH4 MONO, 6 = CH5 / CH6 MONO, 7 = CH7 / CH8 MONO, 8 = DOWN MIX [Default]
		ch_1-4: Output channel 0 = All outputs, 1 = OUT1 to 4 = OUT4
Getting example	Command	@GMD ↵
	Response	@GMD,4,4,8,8 ↵
	Description	Getting the multi channel audio output's setting. OUT1 and OUT2: Outputs monaural audio of CH1 / CH2 OUT3 and OUT4: Outputs downmixed audio.
Setting example	Command	@SMD,1,8 ↵
	Response	@SMD,1,8 ↵
	Description	Setting OUT1 to output downmixed audio.
Remarks		—

@GAT / @SAT		Test tone
Getting	Command	@GAT ↵
	Response	@GAT, tone_1, speaker_1, tone_2, speaker_2, tone_3, speaker_3, tone_4, speaker_4 ↵
Setting	Command	@SAT, ch_1, tone_1, speaker_1 (, ch_2, tone_2, speaker_2···) ↵
	Response	@SAT, ch_1, tone_1, speaker_1 (, ch_2, tone_2, speaker_2···) ↵
Parameter		tone_1-4: Test tone 0 = OFF [Default], 1 = 1 kHz, 2 = 400 Hz
		speaker_1-4: Speaker 0 = ALL [Default], 1 = FRONT L/R, 2 = REAR L/R, 3 = REAR L/R CENTER, 4 = FRONT LEFT, 5 = FRONT RIGHT, 6 = LOW FREQUENCY EFFECT, 7 = FRONT CENTER, 8 = REAR LEFT, 9 = REAR RIGHT, 10 = REAR LEFT CENTER, 11 = REAR RIGHT CENTER
		ch_1-4: Output channel 0 = All outputs, 1 = OUT1 to 4 = OUT4
Getting example	Command	@GAT ↵
	Response	@GAT,2,1,2,1,0,0,0,0 ↵
	Description	Getting the set test tone output. OUT1 and OUT2: Outputs test tone (400 Hz) to FRONT L/R. OUT3 and OUT4: Not output test tone.
Setting example	Command	@SAT,1,1,0 ↵
	Response	@SAT,1,1,0 ↵
	Description	Setting OUT1 to output test tone (1k Hz) to all speakers.
Remarks		—

### 3.3.11 EDID

@GED / @SED		EDID
Getting	Command	@GED ↵
	Response	@GED, edid_1, edid_2, edid_3, edid_4, ..., edid_8 ↵
Setting	Command	@SED, ch_1, edid_1 (, ch_2, edid_2...) ↵
	Response	@SED, ch_1, edid_1 (, ch_2, edid_2...) ↵
Parameter		edid_1-8: EDID 0 = Built-in EDID [Default], 1 = OUT1 MONITOR, 2 = OUT2 MONITOR, 3 = OUT3 MONITOR, 4 = OUT4 MONITOR, 101 to 108 = COPY DATA 1 to COPY DATA 8
		ch_1-8: Input channel 0 = All digital inputs, 1 = IN1 to 8 = IN8
Getting example	Command	@GED ↵
	Response	@GED,0,0,0,3,0,0,0,0 ↵
	Description	Getting the set EDID. IN4: EDID of the sink device that is connected to OUT3, other inputs: built-in EDID
Setting example	Command	@SED,2,3 ↵
	Response	@SED,2,3 ↵
	Description	Setting IN2: EDID that is read from the sink device connected to OUT3.
Remarks		These commands are only for digital input. IN7 and IN8: If "0" (Analog signal) is selected for " <b>@GIN / @SIN Signal selection of DVI input connector</b> ", "-1" is acquired and the setting cannot be valid. In order to use a copied data, read EDID data from the sink device in " <b>@RME Copying EDID</b> " in advance.

<b>@GVF / @SVF</b>		<b>Input resolution for PC</b>
Getting	Command	@GVF
	Response	@GVF, resolution_1, resolution_2, resolution_3, resolution_4, ..., resolution_8 
Setting	Command	@SVF, ch_1, resolution_1 (, ch_2, resolution_2...)
	Response	@SVF, ch_1, resolution_1 (, ch_2, resolution_2...)
Parameter		resolution_1-8: Input resolution for PC 0 = SVGA(800x600),                      1 = XGA(1024x768), 2 = 720p(1280x720),                    3 = WXGA(1280x768), 4 = WXGA(1280x800),                    5 = Quad-VGA(1280x960), 6 = SXGA(1280x1024),                    7 = WXGA(1360x768), 8 = WXGA(1366x768),                    9 = SXGA+(1400x1050), 10 = WXGA+(1440x900),                   11 = WXGA++(1600x900), 12 = UXGA(1600x1200),                   13 = WSXGA+(1680x1050), 14 = 1080i(1920x1080),                   15 = 1080p(1920x1080), 16 = WUXGA(1920x1200),                   17 = QWXGA(2048x1152), 18 = WQHD(2560x1440),                   19 = WQXGA(2560x1600), 40 = 2160p@30(3840x2160) [Default] IN1 to IN8: 1080p(1920x1080)
		ch_1-8: Input channel 0 = All inputs, 1 = IN1 to 8 = IN8
Getting example	Command	@GVF
	Response	@GVF,6,6,9,6,6,6,6,6
	Description	Getting the set input resolution for PC. IN3: SXGA+(1400x1050), other input channels: SXGA(1280x1024)
Setting example	Command	@SVF,0,12
	Response	@SVF,0,12
	Description	Setting EDID of all input channels to UXGA (1600x1200).
Remarks		—

<b>@GHF / @SHF</b>		<b>Input resolution for AV devices</b>
Getting	Command	@GHF 
	Response	@GHF, resolution_1, resolution_2, resolution_3, resolution_4, ..., resolution_8 
Setting	Command	@SHF, ch_1, resolution_1 (, ch_2, resolution_2...) 
	Response	@SHF, ch_1, resolution_1 (, ch_2, resolution_2...) 
Parameter		resolution_1-8: Input resolution for AV devices 0 = UNUSED, 1 = 480p, 2 = 720p, 3 = 1080i, 4 = 1080p, 5 = AUTO [Default], 6 = 2160@30, 9 = 4096x2160@30
		ch_1-8: Input channel 0 = All digital inputs, 1 = IN1 to 8 = IN8
Getting example	Command	@GHF 
	Response	@GHF,5,5,5,4,5,5,5,5 
	Description	Getting the set input resolution for AV devices. IN4: 1080p, other inputs: AUTO
Setting example	Command	@SHF,0,4 
	Response	@SHF,0,4 
	Description	Setting EDIDs of all input channels to 1080p.
Remarks		These commands are only for digital input. IN7 and IN8 are available only when "1" (Digital signal) is selected for " <b>@GIN / @SIN Signal selection of DVI input connector</b> ". If "0" (Analog signal) is selected, "-1" is returned.

@GDI / @SDI		Deep Color input
Getting	Command	@GDI ↵
	Response	@GDI, color_1, color_2, color_3, color_4, ..., color_8 ↵
Setting	Command	@SDI, ch_1, color_1 (, ch_2, color_2...) ↵
	Response	@SDI, ch_1, color_1 (, ch_2, color_2...) ↵
Parameter		color_1-8: Color depth 0 = 24-BIT COLOR [Default], 1 = 30-BIT COLOR
		ch_1-8: Input channel 0 = All digital inputs, 1 = IN1 to 8 = IN8
Getting example	Command	@GDI ↵
	Response	@GDI,1,1,1,0,1,1,1,1 ↵
	Description	Getting the set color depth. IN4: 24-BIT COLOR, Other input channels: 30-BIT COLOR
Setting example	Command	@SDI,4,0 ↵
	Response	@SDI,4,0 ↵
	Description	Setting the set IN4 color depth to 24-BIT COLOR.
Remarks		These commands are only for digital input. IN7 and IN8 are available only when "1" (Digital signal) is selected for " <b>@GIN / @SIN Signal selection of DVI input connector</b> ". If "0" (Analog signal) is selected, "-1" is returned.

<b>@GAF / @SAF</b>		<b>Audio format</b>																
Getting	Command	@GAF, ch [↵]																
	Response	@GAF, ch, format_1, frequency_1 (, format_2, frequency_2···) [↵]																
Setting	Command	@SAF, ch, format_1, frequency_1 (, format_2, frequency_2···) [↵]																
	Response	@SAF, ch, format_1, frequency_1 (, format_2, frequency_2···) [↵]																
Parameter		<p>ch: Input channel 0 = All digital inputs (for setting only), 1 = IN1 to 8 = IN8</p> <p>format_1-8: Audio format 0 = PCM,                    1 = Dolby Digital,    2 = AAC, 3 = Dolby Digital+,    4 = DTS,                5 = DTS-HD, 6 = Dolby TrueHD [Default] only PCM can be output</p> <p>frequency_1-8: Maximum sampling frequency 0 = Not output,    1 = 32 kHz,    2 = 44.1 kHz,    3 = 48 kHz, 4 = 88.2 kHz,    5 = 96 kHz,    6 = 176.4 kHz,    7 = 192 kHz [Default] DTS-HD: 192 kHz, Dolby TrueHD: 96 kHz, other formats: 48 kHz</p> <p>Maximum settable sampling frequency depends on the audio format.</p> <table border="1"> <thead> <tr> <th>Audio format</th> <th>Maximum sampling frequency (kHz)</th> </tr> </thead> <tbody> <tr> <td>PCM</td> <td>32 / 44.1 / 48 / 88.2 / 96 / 176.4 / 192</td> </tr> <tr> <td>Dolby Digital</td> <td>Output disabled / 32 / 44.1 / 48</td> </tr> <tr> <td>AAC</td> <td>Output disabled / 32 / 44.1 / 48 / 88.2 / 96</td> </tr> <tr> <td>Dolby Digital+</td> <td>Output disabled / 32 / 44.1 / 48</td> </tr> <tr> <td>DTS</td> <td>Output disabled / 32 / 44.1 / 48 / 96</td> </tr> <tr> <td>DTS-HD</td> <td>Output disabled / 44.1 / 48 / 88.2 / 96 / 176.4 / 192</td> </tr> <tr> <td>Dolby TrueHD</td> <td>Output disabled / 44.1 / 48 / 88.2 / 96 / 176.4 / 192</td> </tr> </tbody> </table> <p>Getting commands: the set audio formats and maximum sampling frequency is returned. Setting commands: send the desired audio formats and the maximum sampling frequencies. Other audio formats is set to "0" (Output disabled) for the maximum sampling frequency. You do not need to specify "0" parameter normally. PCM is always enabled, you can skip this menu unless you need to change the sampling frequency.</p>	Audio format	Maximum sampling frequency (kHz)	PCM	32 / 44.1 / 48 / 88.2 / 96 / 176.4 / 192	Dolby Digital	Output disabled / 32 / 44.1 / 48	AAC	Output disabled / 32 / 44.1 / 48 / 88.2 / 96	Dolby Digital+	Output disabled / 32 / 44.1 / 48	DTS	Output disabled / 32 / 44.1 / 48 / 96	DTS-HD	Output disabled / 44.1 / 48 / 88.2 / 96 / 176.4 / 192	Dolby TrueHD	Output disabled / 44.1 / 48 / 88.2 / 96 / 176.4 / 192
Audio format	Maximum sampling frequency (kHz)																	
PCM	32 / 44.1 / 48 / 88.2 / 96 / 176.4 / 192																	
Dolby Digital	Output disabled / 32 / 44.1 / 48																	
AAC	Output disabled / 32 / 44.1 / 48 / 88.2 / 96																	
Dolby Digital+	Output disabled / 32 / 44.1 / 48																	
DTS	Output disabled / 32 / 44.1 / 48 / 96																	
DTS-HD	Output disabled / 44.1 / 48 / 88.2 / 96 / 176.4 / 192																	
Dolby TrueHD	Output disabled / 44.1 / 48 / 88.2 / 96 / 176.4 / 192																	
Getting example	Command	@GAF,1 [↵]																
	Response	@GAF,1,0,7 [↵]																
	Description	Getting the set audio formats for IN1. Up to 192 kHz of PCM.																
Setting example	Command	@SAF,2,4,3 [↵]																
	Response	@SAF,2,4,3 [↵]																
	Description	Enabling IN2 to output PCM and DTS up to 48 kHz (PCM's sampling frequency is not changed).																
Remarks		These commands are only for digital input. IN7 and IN8 are available only when "1" (Digital signal) is selected for " <b>@GIN / @SIN Signal selection of DVI input connector</b> ". If "0" (Analog signal) is selected, "-1" is returned.																

@GSP / @SSP		The number of speakers																																																																																																																							
Getting	Command	@GSP, ch <input type="checkbox"/>																																																																																																																							
	Response	@GSP, ch, number, speaker_1 (, speaker_2····) <input type="checkbox"/>																																																																																																																							
Setting	Command	@SSP, ch, number (, speaker_1, speaker_2····) <input type="checkbox"/>																																																																																																																							
	Response	@SSP, ch, number (, speaker_1, speaker_2····) <input type="checkbox"/>																																																																																																																							
Parameter		ch: Input channel 0 = All digital inputs (for setting only), 1 = IN1 to 8 = IN8																																																																																																																							
		number: The number of speakers 1 to 8 [Default] 2																																																																																																																							
Parameter		speaker_1-8: Speaker configuration 0 = Front Left / Right [Default], 1 = Low Frequency Effect, 2 = Front Center, 3 = Rear Left / Right, 4 = Rear Center, 5 = Front Left / Right Center, 6 = Rear Left / Right Center, 7 = Front Left / Right Wide, 8 = Front Left / Right High, 9 = Top Center, 10 = Front Center High																																																																																																																							
		Getting commands: the number of speakers and which speakers will be used is returned. Setting commands: if you do not specify the speaker configuration, the following configuration will be applied depending on the set number of speakers.																																																																																																																							
		<table border="1"> <thead> <tr> <th rowspan="2">number</th> <th colspan="11">speaker</th> </tr> <tr> <th>0</th> <th>1</th> <th>2</th> <th>3</th> <th>4</th> <th>5</th> <th>6</th> <th>7</th> <th>8</th> <th>9</th> <th>10</th> </tr> </thead> <tbody> <tr> <td>1</td> <td>OFF</td> <td>OFF</td> <td>ON</td> <td>OFF</td> <td>OFF</td> <td>OFF</td> <td>OFF</td> <td>OFF</td> <td>OFF</td> <td>OFF</td> <td>OFF</td> </tr> <tr> <td>2</td> <td>ON</td> <td>OFF</td> <td>OFF</td> <td>OFF</td> <td>OFF</td> <td>OFF</td> <td>OFF</td> <td>OFF</td> <td>OFF</td> <td>OFF</td> <td>OFF</td> </tr> <tr> <td>3</td> <td>ON</td> <td>ON</td> <td>OFF</td> <td>OFF</td> <td>OFF</td> <td>OFF</td> <td>OFF</td> <td>OFF</td> <td>OFF</td> <td>OFF</td> <td>OFF</td> </tr> <tr> <td>4</td> <td>ON</td> <td>ON</td> <td>ON</td> <td>OFF</td> <td>OFF</td> <td>OFF</td> <td>OFF</td> <td>OFF</td> <td>OFF</td> <td>OFF</td> <td>OFF</td> </tr> <tr> <td>5</td> <td>ON</td> <td>ON</td> <td>OFF</td> <td>ON</td> <td>OFF</td> <td>OFF</td> <td>OFF</td> <td>OFF</td> <td>OFF</td> <td>OFF</td> <td>OFF</td> </tr> <tr> <td>6</td> <td>ON</td> <td>ON</td> <td>ON</td> <td>ON</td> <td>OFF</td> <td>OFF</td> <td>OFF</td> <td>OFF</td> <td>OFF</td> <td>OFF</td> <td>OFF</td> </tr> <tr> <td>7</td> <td>ON</td> <td>ON</td> <td>ON</td> <td>ON</td> <td>ON</td> <td>OFF</td> <td>OFF</td> <td>OFF</td> <td>OFF</td> <td>OFF</td> <td>OFF</td> </tr> <tr> <td>8</td> <td>ON</td> <td>ON</td> <td>ON</td> <td>ON</td> <td>OFF</td> <td>OFF</td> <td>ON</td> <td>OFF</td> <td>OFF</td> <td>OFF</td> <td>OFF</td> </tr> </tbody> </table>	number	speaker											0	1	2	3	4	5	6	7	8	9	10	1	OFF	OFF	ON	OFF	OFF	OFF	OFF	OFF	OFF	OFF	OFF	2	ON	OFF	OFF	OFF	OFF	OFF	OFF	OFF	OFF	OFF	OFF	3	ON	ON	OFF	OFF	OFF	OFF	OFF	OFF	OFF	OFF	OFF	4	ON	ON	ON	OFF	OFF	OFF	OFF	OFF	OFF	OFF	OFF	5	ON	ON	OFF	ON	OFF	OFF	OFF	OFF	OFF	OFF	OFF	6	ON	ON	ON	ON	OFF	OFF	OFF	OFF	OFF	OFF	OFF	7	ON	ON	ON	ON	ON	OFF	OFF	OFF	OFF	OFF	OFF	8	ON	ON	ON	ON	OFF	OFF	ON	OFF	OFF	OFF	OFF
number	speaker																																																																																																																								
	0	1	2	3	4	5	6	7	8	9	10																																																																																																														
1	OFF	OFF	ON	OFF	OFF	OFF	OFF	OFF	OFF	OFF	OFF																																																																																																														
2	ON	OFF	OFF	OFF	OFF	OFF	OFF	OFF	OFF	OFF	OFF																																																																																																														
3	ON	ON	OFF	OFF	OFF	OFF	OFF	OFF	OFF	OFF	OFF																																																																																																														
4	ON	ON	ON	OFF	OFF	OFF	OFF	OFF	OFF	OFF	OFF																																																																																																														
5	ON	ON	OFF	ON	OFF	OFF	OFF	OFF	OFF	OFF	OFF																																																																																																														
6	ON	ON	ON	ON	OFF	OFF	OFF	OFF	OFF	OFF	OFF																																																																																																														
7	ON	ON	ON	ON	ON	OFF	OFF	OFF	OFF	OFF	OFF																																																																																																														
8	ON	ON	ON	ON	OFF	OFF	ON	OFF	OFF	OFF	OFF																																																																																																														
		For speaker configurations: the <i>number</i> and total number of speakers ( <i>speaker_1-8</i> ) do not match, the <i>number</i> is set automatically based on the setting of <i>speaker_1-8</i> . In case the <i>number</i> exceeds the settable range, an error is returned.																																																																																																																							

<b>@GSP / @SSP</b>		<b>The number of speakers (cont'd)</b>
Getting example	Command	@GSP,1 ↵
	Response	@GSP,1,6,0,1,2,3 ↵
	Description	Getting the IN1 speaker configuration. Six speakers (Front Left / Right, Low Frequency Effect, Front Center, Rear Left / Right) are used.
Setting example	Command	@SSP,2,8 ↵
	Response	@SSP,2,8 ↵
	Description	Setting IN2 speaker configuration to Front Left / Right, Low Frequency Effect, Front Center, Rear Left / Right, Rear Left / Right Center (eight speakers). Completed normally.
Setting example	Command	@SSP,3,8,0,3,5,6,7 ↵
	Response	@ERR,1 ↵
	Description	Setting IN3 speaker configuration to Front Left / Right, Rear Left / Right, Front Left / Right Center, Rear Left / Right Center, Front Left / Right Wide. The number of speakers is 10 which exceeds the settable value, and it causes the error.
Remarks		These commands are only for digital input. IN6 and IN7 are available only when "1" (Digital signal) is selected for " <b>@GIN / @SIN Signal selection of DVI input connector</b> ". If "0" (Analog signal) is selected, "-1" is returned.

<b>@RME</b>		<b>Copying EDID</b>
Setting	Command	@RME, out, number, name ↵
	Response	@RME, out, number, name ↵
Parameter		out: Connector to be loaded 1 = OUT1 to 4 = OUT4
		number: Destination COPY DATA number 1 to 8
		name: COPY DATA name Up to 10 characters using 20 to 7D from ASCII codes. You can skip this setting. In this case, only EDID settings are saved without changing currently saved name.
Setting example	Command	@RME,1,1 ↵
	Response	@RME,1,1 ↵
	Description	Loading EDID data of the sink device connected to OUT1 and saving it in COPY DATA 1.
Setting example	Command	@RME,3,4,800x600 ↵
	Response	@RME,3,4,800x600 ↵
	Description	Loading EDID data of the sink device connected to OUT3, naming it "800x600" and saving it in COPY DATA 4.
Remarks		<b>@GED / @SED EDID</b>

### 3.3.12 RS-232C communication

@GCT / @SCT		RS-232C communication
Getting	Command	@GCT ↵
	Response	@GCT, setting_1, setting_2, setting_3 ↵
Setting	Command	@SCT, port, setting ↵
	Response	@SCT, port, setting ↵
Parameter		setting : Communication setting setting_1 : Communication setting of RS-232C connector setting_2 : Communication setting of HDBaseT input connector IN5 and IN6 setting_3 : Communication setting of HDBaseT output connector OUT1 to OUT4 <ul style="list-style-type: none"> <li>▪ Baud rate (4800, 9600, 19200, 38400 [bps] [Default] 9600)</li> <li>▪ Data length (8, 7 [bit] [Default] 8)</li> <li>▪ Parity check (NONE, EVEN, ODD [Default] NONE)</li> <li>▪ Stop bit (1, 2 [bit] [Default] 1)</li> </ul> For setting values, see the [Table 3.1].
		port: RS-232C channel 0 = All channels, 1 = RS-232C connector, 2 = IN5 to IN6 3 = OUT1 to OUT4
Getting example	Command	@GCT ↵
	Response	@GCT,24,24,24 ↵
	Description	Getting communication settings of RS-232Cs. All baud rates = 19200 [bps], data bit length = 8 [bit], parity check = NONE, stop bit =1 [bit]
Setting example	Command	@SCT,1,24 ↵
	Response	@SCT,1,24 ↵
	Description	Setting RS-232C as follows: baud rate = 19200 [bps], data bit length = 8 [bit], parity check = NONE, stop bit = 1 [bit].
Remarks		If IP address or RS-232C communication setting is changed, the communication may be disabled. Change the environmental settings based on the MSD settings.

[Table 3.1] Parameter of RS-232C communication settings

Value	Communication			
0	4800	8	NONE	1
1	4800	8	NONE	2
2	4800	8	ODD	1
3	4800	8	ODD	2
4	4800	8	EVEN	1
5	4800	8	EVEN	2
6	4800	7	NONE	1
7	4800	7	NONE	2
8	4800	7	ODD	1
9	4800	7	ODD	2
10	4800	7	EVEN	1
11	4800	7	EVEN	2

Value	Communication			
12	9600	8	NONE	1
13	9600	8	NONE	2
14	9600	8	ODD	1
15	9600	8	ODD	2
16	9600	8	EVEN	1
17	9600	8	EVEN	2
18	9600	7	NONE	1
19	9600	7	NONE	2
20	9600	7	ODD	1
21	9600	7	ODD	2
22	9600	7	EVEN	1
23	9600	7	EVEN	2

Value	Communication			
24	19200	8	NONE	1
25	19200	8	NONE	2
26	19200	8	ODD	1
27	19200	8	ODD	2
28	19200	8	EVEN	1
29	19200	8	EVEN	2
30	19200	7	NONE	1
31	19200	7	NONE	2
32	19200	7	ODD	1
33	19200	7	ODD	2
34	19200	7	EVEN	1
35	19200	7	EVEN	2

Value	Communication			
36	38400	8	NONE	1
37	38400	8	NONE	2
38	38400	8	ODD	1
39	38400	8	ODD	2
40	38400	8	EVEN	1
41	38400	8	EVEN	2
42	38400	7	NONE	1
43	38400	7	NONE	2
44	38400	7	ODD	1
45	38400	7	ODD	2
46	38400	7	EVEN	1
47	38400	7	EVEN	2

<b>@GCF / @SCF</b>		<b>RS-232C communication mode</b>
Getting	Command	@GCF ↵
	Response	@GCF, mode_1, ..., mode_11 ↵
Setting	Command	@SCF, port, mode ↵
	Response	@SCF, port, mode ↵
Parameter		<p>mode: Operation mode  mode_1: Operation mode of RS-232C connector  mode_2: Operation mode of HDBaseT input connector IN5  mode_3: Operation mode of HDBaseT input connector IN6  mode_4 to mode_7: Operation mode of HDBaseT output connector OUT1 to OUT4  0 = RECEIVER mode [Default], 1 = TRANSMITTER mode</p> <p>port: RS-232C channel  0 = All channels, 1 = RS-232C connector,  2 = IN5, 3 = IN6,  4 = OUT1, 5 = OUT2,  6 = OUT3, 7 = OUT4</p>
Getting example	Command	@GCF ↵
	Response	@GCF,1,1,1,1,1,1,1 ↵
	Description	Getting the set operation mode TRANSMITTER mode
Setting example	Command	@SCF,1,1 ↵
	Response	@SCF,1,1 ↵
	Description	Setting RS-232C connector to TRANSMITTER mode.
Remarks		<p>These commands are only for RS-232C.</p> <p>If IP address or RS-232C communication setting is changed, the communication may be disabled. Change the environmental settings based on the MSD settings.</p>

<b>@GCI / @SCI</b>		<b>RS-232C transmission</b>
Getting	Command	@GCI ↵
	Response	@GCI, mode ↵
Setting	Command	@SCI, mode ↵
	Response	@SCI, mode ↵
Parameter		mode: RS-232C transmission mode 0 = RS-232C transmission mode OFF, 1 = RS-232C transmission mode ON
Getting example	Command	@GCI ↵
	Response	@GCI,0 ↵
	Description	Getting the set RS-232C transmission mode. Setting the RS-232C transmission mode to OFF.
Setting example	Command	@SCI,1 ↵
	Response	@SCI,1 ↵
	Description	Setting the RS-232C transmission mode to ON.
Remarks		Once RS-232C transmission mode is set to ON, the RS-232C connector cannot be used for communication command control from PC to the MSD or for control command output from the MSD to external devices. Only the command that sets the RS-232C transmission setting to OFF can be accepted.

<b>@GCQ / @SCQ</b>		<b>RS-232C HDBaseT sending channel</b>
Getting	Command	@GCQ
	Response	@GCQ, ch_1 (,ch_2,...,ch_10)
Setting	Command	@SCQ, ch_1 (,ch_2,...)
	Response	@SCQ, ch_1 (,ch_2,...)
Parameter		ch_1-6: RS-232C HDBaseT sending channel 0 = All OUTB channels, 1 = OUT1B to 4 = OUT4B, 105 = IN5B to 106 = IN6B
Getting example	Command	@GCQ
	Response	@GCQ,1,2,3,4
	Description	Getting the set RS-232C HDBaseT sending channel. Setting the OUT1B to OUT4B to RS-232C HDBaseT sending channel.
Setting example	Command	@SCQ,1,4
	Response	@SCQ,1,4
	Description	Setting the OUT1B and OUT4B to RS-232C HDBaseT sending channel.
Remarks		—

<b>@GCR / @SCR</b>		<b>RS-232C HDBaseT receiving channel</b>
Getting	Command	@GCR
	Response	@GCR, channel
Setting	Command	@SCR, channel
	Response	@SCR, channel
Parameter		channel: RS-232C HDBaseT receiving channel 1 = OUT1B to 4 = OUT4B, 105 = IN5B to 106 = IN6B
Getting example	Command	@GCR
	Response	@GCR,4
	Description	Getting the set RS-232C HDBaseT receiving channel setting. Setting the OUT4B to RS-232C HDBaseT receiving channel setting.
Setting example	Command	@SCR,1
	Response	@SCR,1
	Description	Setting the OUT1B to RS-232C HDBaseT receiving channel setting.
Remarks		Only one channel can be set for receiving channel.

### 3.3.13 LAN communication

---

@GIP / @SIP		IP address
Getting	Command	@GIP ↵
	Response	@GIP, unit_1, unit_2, unit_3, unit_4 ↵
Setting	Command	@SIP, unit_1, unit_2, unit_3, unit_4 ↵
	Response	@SIP, unit_1, unit_2, unit_3, unit_4 ↵
Parameter		unit_1 : Upper bit of the IP address to unit_4 : lower bit of the IP address 0 to 255 = 8 bit (Decimal notation) [Default]192.168.1.199
Getting example	Command	@GIP ↵
	Response	@GIP,192,168,3,2 ↵
	Description	Getting the IP address of the MSD. IP address: 192.168.3.2
Setting example	Command	@SIP,192,168,3,2 ↵
	Response	@SIP,192,168,3,2 ↵
	Description	Setting IP address to 192.168.3.2.
Remarks		If IP address or RS-232C communication setting is changed, the communication may be disabled. Change the environmental settings based on the MSD settings.

<b>@GSB / @SSB</b>		<b>Subnet mask</b>
Getting	Command	@GSB ↵
	Response	@GSB, unit_1, unit_2, unit_3, unit_4 ↵
Setting	Command	@SSB, unit_1, unit_2, unit_3, unit_4 ↵
	Response	@SSB, unit_1, unit_2, unit_3, unit_4 ↵
Parameter		unit_1 : Upper bit of the subnet mask to unit_4: lower bit of the subnet mask 0 to 255 = 8 bit (Decimal notation) [Default] 255.255.255.0
Getting example	Command	@GSB ↵
	Response	@GSB,255,255,192,0 ↵
	Description	Getting the set subnet mask of the MSD. Subnet mask: 255.255.192.0 ( = 18 bit)
Setting example	Command	@SSB,255,255,192,0 ↵
	Response	@SSB,255,255,192,0 ↵
	Description	Setting subnet mask to 255.255.192.0 ( = 18 bit).
Remarks		If IP address or RS-232C communication setting is changed, the communication may be disabled. Change the environmental settings based on the MSD settings.

<b>@GGW / @SGW</b>		<b>Gateway address</b>
Getting	Command	@GGW ↵
	Response	@GGW, unit_1, unit_2, unit_3, unit_4 ↵
Setting	Command	@SGW, unit_1, unit_2, unit_3, unit_4 ↵
	Response	@SGW, unit_1, unit_2, unit_3, unit_4 ↵
Parameter		unit_1: Upper bit of the gateway address to unit_4: lower bit of the gateway address 0 to 255 = 8 bit (Decimal notation) [Default]192.168.1.200
Getting example	Command	@GGW ↵
	Response	@GGW,192,168,1,254 ↵
	Description	Getting the set gateway address. Gateway address: 192.168.1.254
Setting example	Command	@SGW,192,168,1,254 ↵
	Response	@SGW,192,168,1,254 ↵
	Description	Setting gateway address to 192.168.1.254.
Remarks		If IP address or RS-232C communication setting is changed, the communication may be disabled. Change the environmental settings based on the MSD settings.

@GLF / @SLF		LAN communication mode
Getting	Command	@GLF, connection <input type="checkbox"/>
	Response	@GLF, connection, mode (, ip_1, ip_2, ip_3, ip_4, pjlink, tcp, password) <input type="checkbox"/>
Setting	Command	@SLF, connection, mode (, ip_1, ip_2, ip_3, ip_4, pjlink, tcp, password) <input type="checkbox"/>
	Response	@SLF, connection, mode (, ip_1, ip_2, ip_3, ip_4, pjlink, tcp, password) <input type="checkbox"/>
Parameter		<p>connection: Connection number 1 = connection 1 to 8 = connection8</p> <p>mode: Operation mode 0 = RECEIVER mode [Default], 1 = TRANSMITTER mode</p> <p>ip_1: Upper bit of the destination IP address to ip_4: lower bit of the destination IP address 0 to 255 = 8 bit (Decimal notation) [Default] 192.168.1.198 Available only if the <i>mode</i> is TRANSMITTER.</p> <p>pjlink: PJLink protocol connection 0 = PJLink not used [Default], 1 = PJLink used Available only if the <i>mode</i> is TRANSMITTER.</p> <p>tcp: Destination port number 1 to 65535 [Default] 1100 Available only if the <i>mode</i> is TRANSMITTER and "pjlink" is set to "0" (PJLink not used). If "pjlink" is set to "1" (PJLink used), "tcp" is "4352" fixed.</p> <p>password: Password of PJLink protocol Up to 32 characters of the following ASCII codes: 20, 30 to 39, 41 to 5A, 61 to 7A (alphanumeric characters). [Default] All: 20 (space) Replied/Set only if the <i>mode</i> is "1" (TRANSMITTER) and <i>pjlink</i> is "0" (PJLink not used). Getting commands: replied only if the password is set. Setting commands: you can skip this password setting if you disable password authentication for PJLink protocol connection. Available only if the <i>mode</i> is TRANSMITTER and "pjlink" is set to "0" (PJLink not used). Getting commands: returned only if the password is set. Setting commands: you can skip this password setting if you do not use password authentication for PJLink protocol connection.</p>
Getting example	Command	@GLF,3 <input type="checkbox"/>
	Response	@GLF,3,1,192,168,1,2,1,PROJECTOR1 <input type="checkbox"/>
Setting example	Description	Getting mode settings of connection 3. Mode = TRANSMITTER mode, destination IP address = 192.168.1.2, PJLink = to be used, password = "PROJECTOR1"
	Command	@SLF,3,1,192,168,1,2,1 <input type="checkbox"/>
Setting example	Response	@SLF,3,1,192,168,1,2,1 <input type="checkbox"/>
	Description	Setting connection 3 as follows: Mode = TRANSMITTER mode, destination IP address = 192.168.1.2, PJLink = to be used, password = disabling password authentication.
Remarks		If IP address or RS-232C communication setting is changed, the communication may be disabled. Change the environmental settings based on the MSD settings.

<b>@GLP / @SLP</b>		<b>TCP port number</b>
Getting	Command	@GLP
	Response	@GLP, port_1, port_2, port_3, port_4, port_5, port_6, port_7, port_8
Setting	Command	@SLP, connection_1, port_1 (, connection_2, port_2···)
	Response	@SLP, connection_1, port_1 (, connection_2, port_2···)
Parameter		connection_1-8: Connection number 0 = All connections, 1 = Connection 1 to 8 = Connection 8 port_1-8: TCP port number 23, 80, 1100, 5000 to 5999, 6000 to 6999 [Default] Connection 1 to 3 = 1100, Connection 4 to 6 = 23, Connection 7 to 8 = 80
Getting example	Command	@GLP
	Response	@GLP,1100,1100,1100,23,23,23,80,80
	Description	Getting the set TCP port number. Connection 1 to 3: 1100, Connection 4 to 6: 23, Connection 7 and 8: 80
Setting example	Command	@SLP,8,6000
	Response	@SLP,8,6000
	Description	Setting port number of connection 8 to "6000".
Remarks		If IP address or RS-232C communication setting is changed, the communication may be disabled. Change the environmental settings based on the MSD settings.

<b>@GMC</b>		<b>MAC address</b>
Getting	Command	@GMC
	Response	@GMC, unit_1, unit_2, unit_3, unit_4, unit_5, unit_6
Parameter		unit_1: Upper bit of the MAC address to unit_6: lower bit of the MAC address 00 to FF = 8 bit (in hexadecimal)
Getting example	Command	@GMC
	Response	@GMC,00,08,E5,5F,00,00
	Description	Getting the set MAC address. MAC address: 00-08-E5-5F-00-00
Remarks		—

### 3.3.14 Control commands

<b>@EXC</b>		<b>Executing control commands</b>
Setting	Command	@EXC, command_1 (, command_2···) ↵
	Response	@EXC, command_1 (, command_2···) ↵
Parameter		command_1-5: Control command 1 = COMMAND 1 to 32 = COMMAND 32
Setting example	Command	@EXC,1,2,3 ↵
	Response	@EXC,1,2,3 ↵
	Description	Executing COMMAND 1→2→3 in order.
Setting example	Command	@EXC,6 ↵
	Response	@EXC,6,RECV:POWER OFF ↵
	Description	Executing COMMAND 6. If a command to display received data is executed, the received result is returned. In this example, "POWER OFF" is received from the target device.
Remarks		Since the result is returned after control command execution is complete, it sometimes may take a time for response.

<b>@GDS / @SDS</b>		<b>Power button of sink device</b>
Getting	Command	@GDS ↵
	Response	@GDS, onoff_1, onoff_2, onoff_3, onoff_4 ↵
Setting	Command	@SDS, ch_1, onoff_1 (, ch_2, onoff_2···) ↵
	Response	@SDS, ch_1, onoff_1 (, ch_2, onoff_2···) ↵
Parameter		onoff_1-4: Power button of sink device 0 = OFF, 1 = ON  ch_1-4: Output channel 0 = All outputs, 1 = OUT1 to 4 = OUT4
Getting example	Command	@GDS ↵
	Response	@GDS,1,1,1,1,1,1,1,1 ↵
	Description	Getting the power button status of sink device. OUT1 and OUT4 powered ON
Setting example	Command	@SDS,1,1 ↵
	Response	@SDS,1,1 ↵
	Description	Setting the power button of the sink device that is connected OUT1 to ON.
Remarks		Since the result is returned after control command execution is complete, it sometimes may take a time for response.

@GEC / @SEC		Control command (Communication command)																																																						
Getting	Command	@GEC, no <input type="checkbox"/>																																																						
	Response	@GEC, no, delay, port, memo, length, command, timeout, retry, interval, retryover, display (, rcv_1, rcv_2...) <input type="checkbox"/>																																																						
Setting	Command	@SEC, no, delay, port, memo, length, command, timeout, retry, interval, retryover, display (, rcv_1, rcv_2...) <input type="checkbox"/>																																																						
	Response	@SEC, no, delay, port, memo, length, command, timeout, retry, interval, retryover, display (, rcv_1, rcv_2...) <input type="checkbox"/>																																																						
Parameter		<p>no: Control command number 1 to 32</p> <p>delay: Delay time 0 = 0 sec. to 999999 = 999.999 sec.</p> <p>port: Output port 1 to 1009661</p> <table border="1"> <tr> <td>bit</td> <td>7</td> <td>6</td> <td>5</td> <td>4</td> <td>3</td> <td>2</td> <td>1</td> <td>0</td> </tr> <tr> <td>port</td> <td>LAN 6</td> <td>LAN 5</td> <td>LAN 4</td> <td>LAN 3</td> <td>LAN 2</td> <td>LAN 1</td> <td>—</td> <td>RS-232C</td> </tr> </table> <table border="1"> <tr> <td>bit</td> <td>15</td> <td>14</td> <td>13</td> <td>12</td> <td>11</td> <td>10</td> <td>9</td> <td>8</td> </tr> <tr> <td>port</td> <td>—</td> <td>IN6B</td> <td>IN5B</td> <td>—</td> <td>—</td> <td>LOOP BACK</td> <td>LAN 8</td> <td>LAN 7</td> </tr> </table> <table border="1"> <tr> <td>bit</td> <td>23</td> <td>22</td> <td>21</td> <td>20</td> <td>19</td> <td>18</td> <td>17</td> <td>16</td> </tr> <tr> <td>port</td> <td>—</td> <td>—</td> <td>—</td> <td>—</td> <td>OUT4B</td> <td>OUT3B</td> <td>OUT2B</td> <td>OUT1B</td> </tr> </table> <p>“1” is for the bit of the output port to send a command (Since bit 1, 11, 12, 15, 20 to 23 are not used, they are always “0”). For example, if you want to send a command from RS-232C CH1, specify “1”. If sending a command from LAN 2, specify “8”.</p> <p>memo: Up to 14 characters of 20 to 7D except 2C (,).</p> <p>length: Data size of send command (the number of bytes) 0 to 30</p> <p>command: Send command data Specify <i>length</i> × 2 digits with 0 to 9, A to F, a to f: (4 bit per digit in hexadecimal).</p> <p>timeout: Time-out duration 0 = 0 sec. to 99999 = 99.999 sec.</p> <p>retry: The number of retries 0 to 99</p> <p>interval: Retry interval 0 = 0 sec. to 99999 = 99.999 sec.</p> <p>retryover: Processing at retry over 0 = Stop processing, 1 = Continue processing</p> <p>display: Displaying received data 0 = communication command control</p>	bit	7	6	5	4	3	2	1	0	port	LAN 6	LAN 5	LAN 4	LAN 3	LAN 2	LAN 1	—	RS-232C	bit	15	14	13	12	11	10	9	8	port	—	IN6B	IN5B	—	—	LOOP BACK	LAN 8	LAN 7	bit	23	22	21	20	19	18	17	16	port	—	—	—	—	OUT4B	OUT3B	OUT2B	OUT1B
bit	7	6	5	4	3	2	1	0																																																
port	LAN 6	LAN 5	LAN 4	LAN 3	LAN 2	LAN 1	—	RS-232C																																																
bit	15	14	13	12	11	10	9	8																																																
port	—	IN6B	IN5B	—	—	LOOP BACK	LAN 8	LAN 7																																																
bit	23	22	21	20	19	18	17	16																																																
port	—	—	—	—	OUT4B	OUT3B	OUT2B	OUT1B																																																

<b>@GEC / @SEC</b>		<b>Control command (Communication command) (cont'd)</b>
Parameter		rcv_1-32: Presence or absence of response command check 1 to 32 For get commands, reply command numbers are separated from each other by a comma. For set commands, the reply command number to be checked can be specified. Up to 32 commands can be specified by separating them by a comma. If you send only parameters of reply command number you want to check, the reply commands without sent parameter are automatically set to "not check". Register reply commands in " <b>@GRC / @SRC Response command</b> ".
Getting example	Command Response	@GEC,1  @GEC,1,10,1,POWER,7,5057204F4E0D0A,1000,2,500,0,0,1,2 
	Description	Getting settings registered in control command 1. <ul style="list-style-type: none"> <li>▪ Delay: 10 ms</li> <li>▪ Output port: RS-232C connector</li> <li>▪ Memo: POWER</li> <li>▪ Data size: 7 bytes</li> <li>▪ Command data: PW ON CR LF (ASCII codes)</li> <li>▪ Timeout: 1000 ms</li> <li>▪ Retry: 2 times</li> <li>▪ Retry interval: 500 ms</li> <li>▪ Retry over: Stop</li> <li>▪ Received data: Not displayed</li> <li>▪ Response command: Check 1 and 2</li> </ul>
Setting example	Command Response	@SEC,2,0,1024,IN1 SELECT,10,405353572C312C310D0A,0,0,0,1,0  @SEC,2,0,1024,IN1 SELECT,10,405353572C312C310D0A,0,0,0,1,0 
	Description	Setting control command 2 as follows: <ul style="list-style-type: none"> <li>▪ Delay: 0 ms</li> <li>▪ Output port: LOOP BACK</li> <li>▪ Memo: IN1 SELECT</li> <li>▪ Data size: 10 bytes</li> <li>▪ Command data: @SSW,1,1 CR LF (ASCII codes)</li> <li>▪ Timeout: 0 ms</li> <li>▪ Retry: 0 time</li> <li>▪ Interval: 0 ms</li> <li>▪ Retry over: Execute</li> <li>▪ Received data: Not displayed</li> <li>▪ Response command: Not checked</li> </ul>
Remarks		—









@GEC / @SEC		Control command (Displaying received data)																		
Getting	Command	@GEC, no ↵																		
	Response	@GEC, no, delay, port, memo, length, command, timeout, retry, interval, retryover, display, delimiter ↵																		
Setting	Command	@SEC, no, delay, port, memo, length, command, timeout, retry, interval, retryover, display, delimiter ↵																		
	Response	@SEC, no, delay, port, memo, length, command, timeout, retry, interval, retryover, display, delimiter ↵																		
Parameter		no: Control command number 1 to 32																		
		delay: Delay time 0 = 0 sec. to 999999 = 999.999 sec.																		
		port: Output port 1 to 1009661																		
		<table border="1"> <tr> <td>bit</td> <td>7</td> <td>6</td> <td>5</td> <td>4</td> <td>3</td> <td>2</td> <td>1</td> <td>0</td> </tr> <tr> <td>port</td> <td>LAN 6</td> <td>LAN 5</td> <td>LAN 4</td> <td>LAN 3</td> <td>LAN 2</td> <td>LAN 1</td> <td>—</td> <td>RS-232C</td> </tr> </table>	bit	7	6	5	4	3	2	1	0	port	LAN 6	LAN 5	LAN 4	LAN 3	LAN 2	LAN 1	—	RS-232C
		bit	7	6	5	4	3	2	1	0										
		port	LAN 6	LAN 5	LAN 4	LAN 3	LAN 2	LAN 1	—	RS-232C										
		<table border="1"> <tr> <td>bit</td> <td>15</td> <td>14</td> <td>13</td> <td>12</td> <td>11</td> <td>10</td> <td>9</td> <td>8</td> </tr> <tr> <td>port</td> <td>—</td> <td>IN6B</td> <td>IN5B</td> <td>—</td> <td>—</td> <td>LOOP BACK</td> <td>LAN 8</td> <td>LAN 7</td> </tr> </table>	bit	15	14	13	12	11	10	9	8	port	—	IN6B	IN5B	—	—	LOOP BACK	LAN 8	LAN 7
		bit	15	14	13	12	11	10	9	8										
		port	—	IN6B	IN5B	—	—	LOOP BACK	LAN 8	LAN 7										
		<table border="1"> <tr> <td>bit</td> <td>23</td> <td>22</td> <td>21</td> <td>20</td> <td>19</td> <td>18</td> <td>17</td> <td>16</td> </tr> <tr> <td>port</td> <td>—</td> <td>—</td> <td>—</td> <td>—</td> <td>OUT4B</td> <td>OUT3B</td> <td>OUT2B</td> <td>OUT1B</td> </tr> </table>	bit	23	22	21	20	19	18	17	16	port	—	—	—	—	OUT4B	OUT3B	OUT2B	OUT1B
		bit	23	22	21	20	19	18	17	16										
		port	—	—	—	—	OUT4B	OUT3B	OUT2B	OUT1B										
		<p>“1” is for the output port to send a command (Since bit 1, 11, 12, 15, 20 to 23 are not used, they are always “0”). For example, if you want to send a command to RS-232C, specify “1”. If sending a command to LAN 2, specify “8”.</p>																		
		memo: Up to 14 characters of 20 to 7D except 2C (,) from ASCII codes.																		
length: Command data size (the number of bites) 0 to 30																				
command: Command data Specify length × 2 digits with 0 to 9, A to F, a to f = 4 bit per digit (in hexadecimal).																				
timeout: Time-out duration 0 = 0 sec. to 99999 = 99.999 sec.																				
retry: The number of retries 0 to 99																				
interval: Retry interval 0 = 0 sec. to 99999 = 99.999 sec.																				
retryover: Processing at retry over 0 = Stop processing, 1 = Continue processing																				
display: Displaying received data 1 = in ASCII codes, 2 = in hexadecimals																				
delimiter 2 digits of 0 to 9, A to F, a to f = 4 bit per digit (in hexadecimal) for monitoring delimiter 100 = Not monitor																				

@GEC / @SEC		Control command (Displaying received data) (cont'd)
Getting example	Command	@GEC,3 ↵
	Response	@GEC,3,0,8,POWER STATUS,9,47455420504F570D0A,2000,2,200,0,1,0D ↵
	Description	Getting settings of control command 3. <ul style="list-style-type: none"> <li>▪ Delay time: 0 ms</li> <li>▪ Output port: LAN2</li> <li>▪ Memo: POWER STATUS</li> <li>▪ Data size: 9 bytes</li> <li>▪ Command data: GET POW CR LF (ASCII codes)</li> <li>▪ Timeout: 2000 ms</li> <li>▪ Retry: 2 times</li> <li>▪ Retry interval: 200 ms</li> <li>▪ Retryover: Stop</li> <li>▪ Received data: Displayed in ASCII codes</li> <li>▪ Delimiter: 0D in hex (CR =ASCII codes)</li> </ul>
Setting example	Command	@SEC,3,0,8,POWER STATUS,9,47455420504F570D0A,2000,2,200,0,1,0D ↵
	Response	@SEC,3,0,8,POWER STATUS,9,47455420504F570D0A,2000,2,200,0,1,0D ↵
	Description	Setting control command 3 as follows: <ul style="list-style-type: none"> <li>▪ Delay time: 0 ms</li> <li>▪ Output port: LAN2</li> <li>▪ Memo: POWER STATUS</li> <li>▪ Data size: 9 bytes</li> <li>▪ Command data: GET POW CR LF (ASCII codes)</li> <li>▪ Timeout: 2000 ms</li> <li>▪ Retry: 2 times</li> <li>▪ Retry interval: 200 ms</li> <li>▪ Retryover: Stop</li> <li>▪ Received data: Displayed in ASCII codes</li> <li>▪ Delimiter: 0D in hex (CR =ASCII codes)</li> </ul>
Remarks		—

@GEC / @SEC		Control command (contact closure)																														
Getting	Command	@GEC, no [↵]																														
	Response	@GEC, no, delay, port, memo, ccno_1, cc_1, pulse_1 (, ccno_2, cc_2, pulse_2···) [↵]																														
Setting	Command	@SEC, no, delay, port, memo, ccno_1, cc_1, pulse_1 (, ccno_2, cc_2, pulse_2···) [↵]																														
	Response	@SEC, no, delay, port, memo, ccno_1, cc_1, pulse_1 (, ccno_2, cc_2, pulse_2···) [↵]																														
Parameter		<p>no: Control command number 1 to 32</p> <p>delay: Delay time 0 = 0 sec. to 999999 = 999.999 sec.</p> <p>port: Contact closure control 2048= For contact closure control</p> <p>memo: Up to 14 characters of 20 to 7D except 2C (,) from ASCII codes.</p> <p>ccno_1-8: Contact closure number</p> <table border="1" style="width: 100%; border-collapse: collapse; text-align: center;"> <tr> <td style="width: 10%;">ccno</td> <td>1</td> <td>2</td> <td>3</td> <td>4</td> <td>5</td> <td>6</td> <td>7</td> <td>8</td> <td>9</td> </tr> <tr> <td>Contact closure</td> <td colspan="3">CONTACT CLOSURE 1</td> <td colspan="3">CONTACT CLOSURE 2</td> <td colspan="3">CONTACT CLOSURE 3</td> </tr> <tr> <td></td> <td>CH1</td> <td>CH2</td> <td>CH3</td> <td>CH1</td> <td>CH2</td> <td>CH3</td> <td>CH1</td> <td>CH2</td> <td>CH3</td> </tr> </table> <p>cc_1-8: Contact closure control 0 = OFF, 1 = ON, 2 = Toggle, 3 = Not control</p> <p>pulse_1-8: pulse width 0 = Hold, 100 = 100 ms to 9990 = 9990 ms (by 10 ms) Pulse width after the completion of contact closure.</p> <p>Getting commands: only contact closure numbers to be controlled are replied. Setting commands: specify only contact closure numbers to be controlled. For contact closure numbers that do not specify parameter, "Not check" is set.</p>	ccno	1	2	3	4	5	6	7	8	9	Contact closure	CONTACT CLOSURE 1			CONTACT CLOSURE 2			CONTACT CLOSURE 3				CH1	CH2	CH3	CH1	CH2	CH3	CH1	CH2	CH3
ccno	1	2	3	4	5	6	7	8	9																							
Contact closure	CONTACT CLOSURE 1			CONTACT CLOSURE 2			CONTACT CLOSURE 3																									
	CH1	CH2	CH3	CH1	CH2	CH3	CH1	CH2	CH3																							
Getting example	Command Response	@GEC,7 [↵] @GEC,7,20,2048,SCREEN UP,1,1,100 [↵]																														
	Description	Getting settings of control command 7. <ul style="list-style-type: none"> <li>▪ Delay time: 20ms</li> <li>▪ Memo: SCREEN UP</li> <li>▪ Contact closure1's CH1: ON for 100 ms</li> <li>▪ Other outputs: not controlled.</li> </ul>																														
Setting example	Command Response	@SEC,6,50,2048,PROJECTOR ON,1,0,200,2,1,0 [↵] @SEC,6,50,2048,PROJECTOR ON,1,0,200,2,1,0 [↵]																														
	Description	Setting Control command number 6 as follows: <ul style="list-style-type: none"> <li>▪ Delay time: 50 ms</li> <li>▪ Memo: PROJECTOR ON</li> <li>▪ CH1 of contact closure1 : ON for 200 ms</li> <li>▪ CH2 of contact closure : ON</li> <li>▪ Other contact closure : Not controlled</li> </ul>																														
Remarks		—																														

@GEC / @SEC		Control command (CEC)
Getting	Command	@GEC, no
	Response	@GEC, no, delay, port, memo, error, ch_1, cec_1 (, ch_2, cec_2····)
Setting	Command	@SEC, no, delay, port, memo, error, ch_1, cec_1 (, ch_2, cec_2····)
	Response	@SEC, no, delay, port, memo, error, ch_1, cec_1 (, ch_2, cec_2····)
Parameter		<p>no: Control command number 1 to 32</p> <p>delay: Delay time 0 = 0 sec. to 999999 = 999.999 sec.</p> <p>port: CEC 4096 = For CEC control</p> <p>memo: Up to 14 characters of 20 to 7D except 2C (,) from ASCII codes.</p> <p>error: Processing if no response from sink device. 0 = Stop processing, 1 = Continue processing</p> <p>ch_1-4: Output channel 1 = OUT1 to 4 = OUT4</p> <p>cec_1-8: Control command 0 = Not controlled, 1 = POWER OFF, 2 = POWER ON</p> <p>Getting commands: the control output connector and control command are separated from each other by a comma. Setting commands: specify output connector to be controlled and control commands. For outputs that do not specify parameter, "Not check" is set.</p>
Getting example	Command	@GEC,7
	Response	@GEC,7,0,4096,DISPLAY1 ON,0,1,2
	Description	<p>Getting settings of control command 7.</p> <ul style="list-style-type: none"> <li>• Delay time: 0 ms</li> <li>• Memo: DISPLAY1 ON</li> <li>• Error: Stop</li> <li>• OUT1 sink device: Turning on.</li> <li>• Other outputs: not controlled.</li> </ul>
Setting example	Command	@SEC,7,0,4096,DISPLAY1 ON,0,1,2
	Response	@SEC,7,0,4096,DISPLAY1 ON,0,1,2
	Description	<p>Setting control command 7 as follows:</p> <ul style="list-style-type: none"> <li>• Delay time:0 ms</li> <li>• Memo: DISPLAY1 ON</li> <li>• Error: Stop</li> <li>• OUT1 sink device: Power ON.</li> <li>• Other outputs: not controlled.</li> </ul>
Remarks		—

@GRC / @SRC		Response command
Getting	Command	@GRC, no ↵
	Response	@GRC, no, process, length, command, mask, memo ↵
Setting	Command	@SRC, no, process, length, command, mask, memo ↵
	Response	@SRC, no, process, length, command, mask, memo ↵
Parameter		no: Response command number 1 to 32
		process 0 = Stop, 1 = Continue, 2 = Resending commands
		length: Reply command data size (bytes) 0 to 30
		command: Reply command data length × 2 digits with 0 to 9, A to F, a to f = 4 bit per digit (in hexadecimal)
		mask: Mask data length × 2 digits with 0 to 9, A to F, a to f = 4 bit per digit (in hexadecimal)
		memo: Up to 14 characters of 20 to 7D except 2C (,) from ASCII codes.
Getting example	Command	@GRC,2 ↵
	Response	@GRC,2,0,1,40,40,NG ↵
	Description	Getting settings of reply command 2: <ul style="list-style-type: none"> <li>▪ Processing: Stop</li> <li>▪ Data size: 1 byte</li> <li>▪ Command data: 40 (in hex)</li> <li>▪ Mask data: 40 (checking the second bit from the top)</li> <li>▪ Memo: NG (no good)</li> </ul>
Setting example	Command	@SRC,1,1,9,52454356204F4B0D0A,FFFFFFFFFFFFFFFFFFFF,OK ↵
	Response	@SRC,1,1,9,52454356204F4B0D0A,FFFFFFFFFFFFFFFFFFFF,OK ↵
	Description	Setting reply command 1 as follows: <ul style="list-style-type: none"> <li>▪ Processing: Continue</li> <li>▪ Data size: 9 bytes</li> <li>▪ Command data: RECV OK CR LF (ASCII)</li> <li>▪ Mask data: ALL: FF (checking all bits)</li> <li>▪ Memo: OK</li> </ul>
Remarks		—









<b>@GCC / @SCC</b>		<b>Control command link</b>
Getting	Command	@GCC, event 
	Response	@GCC, event, c_1 (, c_2, c_3···) 
Setting	Command	@SCC, event, c_1 (, c_2, c_3···) 
	Response	@SCC, event, c_1 (, c_2, c_3···) 
Parameter		<p>event: Control command execution condition For settable values, see the <b>[Table 3.2]</b>.</p> <p>c_1-10: Send command 0 = Not link [Default], 1 to 32 = Control command 1 to 32 Control commands that are registered in one of the following commands can be linked.</p> <p><b>@GEC / @SEC Control command (Communication command),</b> <b>@GEC / @SEC Control command (Displaying received data),</b> <b>@GEC / @SEC Control command (contact closure),</b> <b>@GEC / @SEC Control command (CEC).</b></p>
Getting example	Command	@GCC,19 
	Response	@GCC,19,5,2,1 
	Description	Getting control commands that will be executed when the MSD is powered on. Executing in order of control command 5, 2, and 1.
Setting example	Command	@SCC,19,5,2,1 
	Response	@SCC,19,5,2,1 
	Description	Executing in order of control command 5, 2, and 1 when the MSD is powered on.
Remarks		—





**[Table 3.2] Parameter of control command execution condition**

event	Execution condition	event	Execution condition	event	Execution condition
1	COMMAND A-PLANE A	37	VIDEO:OUT1-IN1	73	VIDEO:OUT3-IN1
2	COMMAND A-PLANE B	38	VIDEO:OUT1-IN2	74	VIDEO:OUT3-IN2
3	COMMAND B-PLANE A	39	VIDEO:OUT1-IN3	75	VIDEO:OUT3-IN3
4	COMMAND B-PLANE B	40	VIDEO:OUT1-IN4	76	VIDEO:OUT3-IN4
5	COMMAND C-PLANE A	41	VIDEO:OUT1-IN5	77	VIDEO:OUT3-IN5
6	COMMAND C-PLANE B	42	VIDEO:OUT1-IN6	78	VIDEO:OUT3-IN6
7	COMMAND D-PLANE A	43	VIDEO:OUT1-IN7	79	VIDEO:OUT3-IN7
8	COMMAND D-PLANE B	44	VIDEO:OUT1-IN8	80	VIDEO:OUT3-IN8
9	COMMAND E-PLANE A	45	VIDEO:OUT1-OFF	81	VIDEO:OUT3-OFF
10	COMMAND E-PLANE B	46	AUDIO:OUT1-IN1	82	AUDIO:OUT3-IN1
11	COMMAND F-PLANE A	47	AUDIO:OUT1-IN2	83	AUDIO:OUT3-IN2
12	COMMAND F-PLANE B	48	AUDIO:OUT1-IN3	84	AUDIO:OUT3-IN3
13	COMMAND G-PLANE A	49	AUDIO:OUT1-IN4	85	AUDIO:OUT3-IN4
14	COMMAND G-PLANE B	50	AUDIO:OUT1-IN5	86	AUDIO:OUT3-IN5
15	COMMAND H-PLANE A	51	AUDIO:OUT1-IN6	87	AUDIO:OUT3-IN6
16	COMMAND H-PLANE B	52	AUDIO:OUT1-IN7	88	AUDIO:OUT3-IN7
17	COMMAND I-PLANE A	53	AUDIO:OUT1-IN8	89	AUDIO:OUT3-IN8
18	COMMAND I-PLANE B	54	AUDIO:OUT1-OFF	90	AUDIO:OUT3-OFF
19	POWER ON	55	VIDEO:OUT2-IN1	91	VIDEO:OUT4-IN1
20	POWER OFF	56	VIDEO:OUT2-IN2	92	VIDEO:OUT4-IN2
21	DISPLAY1 POWER ON	57	VIDEO:OUT2-IN3	93	VIDEO:OUT4-IN3
22	DISPLAY1 POWER OFF	58	VIDEO:OUT2-IN4	94	VIDEO:OUT4-IN4
23	DISPLAY2 POWER ON	59	VIDEO:OUT2-IN5	95	VIDEO:OUT4-IN5
24	DISPLAY2 POWER OFF	60	VIDEO:OUT2-IN6	96	VIDEO:OUT4-IN6
25	DISPLAY3 POWER ON	61	VIDEO:OUT2-IN7	97	VIDEO:OUT4-IN7
26	DISPLAY3 POWER OFF	62	VIDEO:OUT2-IN8	98	VIDEO:OUT4-IN8
27	DISPLAY4 POWER ON	63	VIDEO:OUT2-OFF	99	VIDEO:OUT4-OFF
28	DISPLAY4 POWER OFF	64	AUDIO:OUT2-IN1	100	AUDIO:OUT4-IN1
		65	AUDIO:OUT2-IN2	101	AUDIO:OUT4-IN2
		66	AUDIO:OUT2-IN3	102	AUDIO:OUT4-IN3
		67	AUDIO:OUT2-IN4	103	AUDIO:OUT4-IN4
		68	AUDIO:OUT2-IN5	104	AUDIO:OUT4-IN5
		69	AUDIO:OUT2-IN6	105	AUDIO:OUT4-IN6
		70	AUDIO:OUT2-IN7	106	AUDIO:OUT4-IN7
		71	AUDIO:OUT2-IN8	107	AUDIO:OUT4-IN8
		72	AUDIO:OUT2-OFF	108	AUDIO:OUT4-OFF

<b>@GTG / @STG</b>		<b>Toggle operation</b>
Getting	Command	@GTG, event_1 (, event_2····)
	Response	@GTG, event_1, toggle_1 (, event_2, toggle_2····)
Setting	Command	@STG, event_1, toggle_1 (, event_2, toggle_2····)
	Response	@STG, event_1, toggle_1 (, event_2, toggle_2····)
Parameter		event_1-9: Command execution condition 0 = All control commands, 1 = COMMAND A to 9 = COMMAND I
		toggle_1-9: Toggle operation 0 = Disabled [Default], 1 = Enabled
Getting example	Command	@GTG,1
	Response	@GTG,1,1
	Description	Getting the toggle operation of COMMAND A. COMMAND A: Toggle operation enabled.
Setting example	Command	@STG,1,1
	Response	@STG,1,1
	Description	Enabling COMMAND A's toggle operation COMMAND A.
Remarks		—

<b>@GUP / @SUP</b>		<b>Plane to be executed when powered ON</b>
Getting	Command	@GUP, event_1 (, event_2····)
	Response	@GUP, event_1, plane_1 (, event_2, plane_2····)
Setting	Command	@SUP, event_1, plane_1 (, event_2, plane_2····)
	Response	@SUP, event_1, plane_1 (, event_2, plane_2····)
Parameter		event_1-9: Command execution condition 0 = All control commands, 1 = COMMAND A to 9 = COMMAND I
		plane_1-9: Plane to be executed when powered ON 0 = AUTO [Default], 1 = PLANE A, 2 = PLANE B
Getting example	Command	@GUP,1
	Response	@GUP,1,1
	Description	Getting the plane to be executed for COMMAND A. COMMAND A executes PLANE A.
Setting example	Command	@SUP,1,1
	Response	@SUP,1,1
	Description	Setting COMMAND A to execute PLANE A.
Remarks		—

<b>@GIT / @SIT</b>		<b>Ineffective time during control command execution</b>
Getting	Command	@GIT 
	Response	@GIT, time 
Setting	Command	@SIT, time 
	Response	@SIT, time 
Parameter		time: Invalid time 0 = 0 sec. to 999999 = 999.999 sec. [Default] 0 sec.
Getting example	Command	@GIT 
	Response	@GIT,2000 
	Description	Getting ineffective time of control command execution. Disabling operation during control command execution or 2000 ms. (2 seconds) after control command starts.
Setting example	Command	@SIT,2000 
	Response	@SIT,2000 
	Description	Setting ineffective time during control command execution to 2000 ms. (2 seconds).
Remarks		—

<b>@DEC</b>		<b>Initializing registered command and link</b>
Setting	Command	@DEC, no_1 (, no_2, no_3···) 
	Response	@DEC, no_1 (, no_2, no_3···) 
Parameter		no_1-32: Commands or links you want to initialize 1 to 32: Control commands 1 to 32 101 to 132: Response commands 1 to 32 ("1xx": xx is the response command number)  【See: @GRC / @SRC Response command】  201 to 380: Control command links 1 to 5 ("2xx": xx is the control command execution condition)  【See: @GCC / @SCC Control command link】
Setting example	Command	@DEC,201 
	Response	@DEC,201 
	Description	Deleting the link between COMMAND A and PLANE A.
Remarks		—

@GTL / @STL		Lighting condition of execution button
Getting	Command	@GTL, switch_1 (, switch_2···) ↵
	Response	@GTL, switch_1, led_1 (, switch_2, led_2···) ↵
Setting	Command	@STL, switch_1, led_1 (, switch_2, led_2···) ↵
	Response	@STL, switch_1, led_1 (, switch_2, led_2···) ↵
Parameter		<p>switch_1-9: Command execution button  0 = All command execution buttons  1 = COMMAND A to 9 = COMMAND I</p> <p>led_1-9 : Lighting condition  If a control command(s) having only one PLANE, PLANE A or PLANE B is linked to a control command execution button:  0 = Lights when a control command is registered. [Default]  1 = Lights while a control command is being executed.</p> <p>If a control command(s) having two PLANEs, PLANE A and PLANE B is linked to a control command execution button:  0 = A control command(s) that is linked to a button is executed by pressing the desired button when the control command execution button lights/blinks.  Lights: Control command registered to PLANE A.  Blinks: Control command registered to PLANE B.  1 = The control command that is linked to a button is executed by pressing a desired button when the control command execution button lights/goes out.  Lights: Control command registered to PLANE A  Goes out: Control command registered to PLANE B</p>
Getting example	Command	@GTL,5 ↵
	Response	@GTL,5,0 ↵
	Description	Getting the lighting condition of the COMMAND E. The COMMAND E lights if a control command is registered. (If one PLANE is linked)
Setting example	Command	@STL,5,1 ↵
	Response	@STL,5,1 ↵
	Description	Setting the COMMAND E to light while a command is being executed. (If one PLANE is linked)
Remarks		—

<b>@GTF / @STF</b>		<b>Blinking time of sink device power switch</b>
Getting	Command	@GTF, switch_1 (, switch_2····) ↵
	Response	@GTF, switch_1, flash_1 (, switch_2, flash_2····) ↵
Setting	Command	@STF, switch_1, flash_1 (, switch_2, flash_2····) ↵
	Response	@STF, switch_1, flash_1 (, switch_2, flash_2····) ↵
Parameter		<p>switch_1-9: Key group  0 = All keys, 1 = COMMAND A to 5 = COMMAND E  10 = DISPLAY1 POWER to 13 = DISPLAY4 POWER</p> <p>flash_1-9: Blinking time  -1 = Links during control command execution,  0 = Not blink,  1 to 1000 = Blinks for 1 sec. to 1000 sec.  [Default] COMMAND A to COMMAND E = 0,  DISPLAY1 POWER to DISPLAY4 POWER = -1</p>
Getting example	Command	@GTF,1 ↵
	Response	@GTF,1,-1 ↵
	Description	Getting blinking time of COMMAND A. The switch will be blinked while control command is being executed.
Setting example	Command	@STF,1,5 ↵
	Response	@STF,1,5 ↵
	Description	Setting COMMAND A to blink 5 seconds after control command execution starts.
Remarks		—

### 3.3.15 Preset memory

<b>@RCM</b>		<b>Loading crosspoint memory</b>
Setting	Command	@RCM, memory ↵
	Response	@RCM, memory ↵
Parameter		memory: Crosspoint memory 1 to 9
Setting example	Command	@RCM,1 ↵
	Response	@RCM,1 ↵
	Description	Loading video and audio channels of crosspoint memory 1.
Remarks		—

<b>@SCM / @SEM</b>		<b>Saving channels to crosspoint memory</b>
Setting	Description	Overwriting all
	Command	@SCM, memory (, name) ↵
	Response	@SCM, memory (, name) ↵
Setting	Description	Overwriting partly
	Command	@SEM, memory (, name) ↵
	Response	@SEM, memory (, name) ↵
Parameter		memory: Crosspoint memory 1 to 9  name: Memory name Up to 10 characters using 20 to 7D from ASCII codes. If you do not specify memory name, only crosspoint settings are saved without changing the current memory name.
Setting example	Command Response	@SCM,2 ↵ @SCM,2 ↵
	Description	Saving the current video and audio channels to crosspoint memory 2 without changing the memory name.
Setting example	Command Response	@SEM,2,PATTERN2 ↵ @SEM,2,PATTERN2 ↵
	Description	Saving the current video and audio channels to crosspoint memory 2 with the name of "PATTERN2". Output settings that are set to Not Controlled are not saved.
Remarks		—

<b>@GCM / @ECM</b>		<b>Editing crosspoint memory</b>
Getting	Command	@GCM, memory <input type="button" value="↵"/>
	Response	@GCM, memory, v_1, a_1, v_2, a_2, v_3, a_3, v_4, a_4, name <input type="button" value="↵"/>
Setting	Command	@ECM, memory, v_1, a_1, v_2, a_2, v_3, a_3, v_4, a_4 <input type="button" value="↵"/>
	Response	@ECM, memory, v_1, a_1, v_2, a_2, v_3, a_3, v_4, a_4 <input type="button" value="↵"/>
Parameter		memory: Crosspoint memory 1 to 9
		v_1-4: Video channel a_1-4: Audio channel -1 = Not controlled [Default], 0 = OFF, 1 = IN1 to 8 = IN8
		name: Memory name Up to 10 characters using 20 to 7D from ASCII codes. [Default] 20 (space)
Getting example	Command	@GCM,2 <input type="button" value="↵"/>
	Response	@GCM,2,3,3,1,1,-1,-1,-1,-1,PATTERN2 <input type="button" value="↵"/>
	Description	Getting the video and audio channels of crosspoint memory 2. OUT1: IN3, OUT2: IN1 are saved with the name of "PATTERN2", OUT3 to OUT4: Not controlled but saved
Setting example	Command	@ECM,2,1,1,-1,-1,-1,-1,-1 <input type="button" value="↵"/>
	Response	@ECM,2,1,1,-1,-1,-1,-1,-1 <input type="button" value="↵"/>
	Description	Setting the crosspoint memory 2 to: OUT1: IN1, OUT2 to OUT4: Not controlled
Remarks		Nothing is saved in the memory by factory default, the state is "-1" (Not controlled). If you save only video (@SCV) or audio (@SCA) at the first saving of crosspoint settings, "-1" (Not controlled) is returned to unsaved audio and video.

<b>@RCV</b>		<b>Loading crosspoint memory (setting video channel)</b>
Setting	Command	@RCV, memory <input type="button" value="↵"/>
	Response	@RCV, memory <input type="button" value="↵"/>
Parameter		memory: Crosspoint memory 1 to 9
Getting example	Command	@RCV,1 <input type="button" value="↵"/>
	Response	@RCV,1 <input type="button" value="↵"/>
	Description	Loading video channel of crosspoint memory 1.
Remarks		—

<b>@SCV / @SEV</b>		<b>Saving crosspoint memory (Setting video channel)</b>
Setting	Description	Overwriting all
	Command	@SCV, memory (, name)
	Response	@SCV, memory (, name)
Setting	Description	Overwriting partly
	Command	@SEV, memory (, name)
	Response	@SEV, memory (, name)
Parameter		memory: Crosspoint memory 1 to 9
		name: Memory name Up to 10 characters using 20 to 7D from ASCII codes. If you do not specify memory name, only settings of crosspoint are saved without changing the memory name.
Setting example	Command	@SCV,2
	Response	@SCV,2
	Description	Saving the current video channel in crosspoint memory 2 without changing memory name.
Setting example	Command	@SEV,2,PATTERN2
	Response	@SEV,2,PATTERN2
	Description	Saving the current video channel in crosspoint memory 2 with the name of "PATTERN2". Output settings that are set to Not Controlled are not saved.
Remarks		—

<b>@GCV / @ECV</b>		<b>Editing crosspoint memory (Setting video channel)</b>
Getting	Command	@GCV, memory
	Response	@GCV, memory, v_1, v_2, v_3, v_4, name
Setting	Command	@ECV, memory, v_1, v_2, v_3, v_4
	Response	@ECV, memory, v_1, v_2, v_3, v_4
Parameter		memory: Crosspoint memory 1 to 9
		v_1-4: Video channel -1 = Not controlled [Default], 0 = OFF, 1 = IN1 to 8 = IN8
		name: Memory name Up to 10 characters using 20 to 7D from ASCII codes. [Default] 20 (space)
Getting example	Command	@GCV,2
	Response	@GCV,2,3,1,1,1,PATTERN2
	Description	Getting video channel of crosspoint memory 2. OUT1: IN3, Other outputs: IN1 are saved with the name of "PATTERN2".
Setting example	Command	@ECV,2,1,1,-1,-1
	Response	@ECV,2,1,1,-1,-1
	Description	When crosspoint memory 2 is loaded, OUT1 and OUT2 are set to IN1, OUT3 and OUT4 are set to Not Controlled.
Remarks		Nothing is saved in the memory by factory default, the state is "-1" (Not controlled). If you save only audio (@SCA) at the first saving of crosspoint settings, "-1" (Not controlled) is returned to unsaved audio and video.

<b>@RCA</b>		<b>Loading audio channel setting from crosspoint memory</b>
Setting	Command	@RCA, memory ↵
	Response	@RCA, memory ↵
Parameter		memory: Crosspoint memory 1 to 9
Setting example	Command	@RCA,1 ↵
	Response	@RCA,1 ↵
	Description	Loading audio channel of crosspoint memory 1.
Remarks		—

<b>@SCA / @SEA</b>		<b>Saving crosspoint memory (Setting audio channel)</b>
Setting	Description	Overwriting all
	Command	@SCA, memory, name ↵
	Response	@SCA, memory, name ↵
Setting	Description	Overwriting partly
	Command	@SEA, memory (, name) ↵
	Response	@SEA, memory (, name) ↵
Parameter		memory: Crosspoint memory 1 to 9
		name: Memory name Up to 10 characters using 20 to 7D from ASCII codes. If you do not specify memory name, only crosspoint settings are saved without changing the memory name.
Setting example	Command	@SCA,2 ↵
	Response	@SCA,2 ↵
	Description	Saving the current audio channel in crosspoint memory 2 without changing memory name.
Setting example	Command	@SEA,2,PATTERN2 ↵
	Response	@SEA,2,PATTERN2 ↵
	Description	Saving the current video channel in crosspoint memory 2 with the name of "PATTERN2". Output settings that are set to Not Controlled are not saved.
Remarks		—

<b>@GCA / @ECA</b>		<b>Editing crosspoint memory (Setting audio channel)</b>
Getting	Command	@GCA, memory ↵
	Response	@GCA, memory, a_1, a_2, a_3, a_4, name ↵
Setting	Command	@ECA, memory, a_1, a_2, a_3, a_4 ↵
	Response	@ECA, memory, a_1, a_2, a_3, a_4 ↵
Parameter		memory: Crosspoint memory 1 to 9
		a_1-4: Audio channel -1 = Not controlled [Default], 0 = OFF, 1 = IN1 to 8 = IN8
		name: Memory name Up to 10 characters using 20 to 7D from ASCII codes. [Default] 20 (space)
Getting example	Command	@GCA,2 ↵
	Response	@GCA,2,3,3,1,1,PATTERN2 ↵
	Description	Getting audio channel of crosspoint memory 2. OUT1 and OUT2: IN3, OUT3 and OUT4: IN1 are saved with the name of "PATTERN2"
Setting example	Command	@ECA,2,1,2,3,4 ↵
	Response	@ECA,2,1,2,3,4 ↵
	Description	When crosspoint memory 2 is loaded, outputs are set as follows: OUT1: IN1, OUT2: IN2, OUT3: IN3, OUT4: audio channel of IN4
Remarks		Nothing is saved in the memory by factory default, the state is "-1" (Not controlled). If you save only video (@SCV) at the first saving of crosspoint settings, "-1" (Not controlled) is returned to unsaved audio and video.

<b>@RPM</b>		<b>Loading all settings</b>
Setting	Command	@RPM, preset ↵
	Response	@RPM, preset ↵
Parameter		preset: Preset memory 1 to 12
Setting example	Command	@RPM,3 ↵
	Response	@RPM,3 ↵
	Description	Loading preset memory 3.
Remarks		Once preset memory is loaded, all settings of video and audio I/O except for some environmental settings will be updated.

<b>@SPM</b>		<b>Saving all settings</b>
Setting	Command	@SPM, preset (, name) ↵
	Response	@SPM, preset (, name) ↵
Parameter		preset: Preset memory 1 to 12
		name: Memory name Up to 10 characters using 20 to 7D from ASCII codes. If you do not specify memory name, only crosspoint settings are saved without changing the memory name.
Setting example	Command	@SPM,2 ↵
	Response	@SPM,2 ↵
	Description	Saving the current settings in preset memory 2 without changing the memory name.
Setting example	Command	@SPM,2,MEMORY2 ↵
	Response	@SPM,2,MEMORY2 ↵
	Description	Saving the current settings in preset memory 2 with the name of "MEMORY2".
Remarks		—

<b>@SCP</b>		<b>Copying output setting</b>
Setting	Command	@SCP, out_ori, out_des ↵
	Response	@SCP, out_ori, out_des ↵
Parameter		out_ori: Source output channel 1 = OUT1 to 4 = OUT4
		out_des: Destination output channel 1 = OUT1 to 4 = OUT4
Setting example	Command	@SCP,2,1 ↵
	Response	@SCP,2,1 ↵
	Description	Copying OUT2's setting to OUT1.
Remarks		Once output setting is copied, all settings related to output are copied.

<b>@GMU / @SMU</b>		<b>Startup settings</b>
Getting	Command	@GMU ↵
	Response	@GMU, state ↵
Setting	Command	@SMU, state ↵
	Response	@SMU, state ↵
Parameter		state: Startup settings 1 to 9 = Crosspoint memory 1 to 9, 10 = Channel OFF, 11 = Last channel [Default], 12 to23 = Preset memory 1 to 12
Getting example	Command	@GMU ↵
	Response	@GMU,3 ↵
	Description	Getting settings for startup. Channel settings of crosspoint memory 3.
Setting example	Command	@SMU,3 ↵
	Response	@SMU,3 ↵
	Description	Setting startup channel settings to crosspoint memory 3.
Remarks		—

### 3.3.16 Bitmap

<b>@GBM / @SBM</b>		<b>Outputting bitmap image</b>
Getting	Command	@GBM ↵
	Response	@GBM, out_1, out_2, out_3, out_4 ↵
Setting	Command	@SBM, ch_1, out_1 (, ch_2, out_2···) ↵
	Response	@SBM, ch_1, out_1 (, ch_2, out_2···) ↵
Parameter		out_1-4: Outputting bitmap image 0 = OFF [Default], 1 = Bitmap 1 ON, 2 = Bitmap 2 ON, 3 = Bitmap 3 ON, 4 = Bitmap 4 ON Only registered numbers can be specified. ch_1-4: Output channel 0 = All outputs, 1 = OUT1 to 4 = OUT4
Getting example	Command	@GBM ↵
	Response	@GBM,1,0,0,0,0,0,0 ↵
	Description	Getting the output image. OUT1: bitmap 1, OUT2 to OUT4: not output a bitmap image.
Setting example	Command	@SBM,1,1 ↵
	Response	@SBM,1,1 ↵
	Description	Outputting bitmap 1 image to OUT1.
Remarks		—

<b>@GBB / @SBB</b>		<b>Background color</b>
Getting	Command	@GBB, ch
	Response	@GBB, ch, red_1, green_1, blue_1, red_2, green_2, blue_2, red_3, green_3, blue_3, red_4, green_4, blue_4
Setting	Command	@SBB, ch_1, bitmap_1, red_1, green_1, blue_1 (, ch_2, bitmap_2, red_2, green_2, blue_2···)
	Response	@SBB, ch_1, bitmap_1, red_1, green_1, blue_1 (, ch_2, bitmap_2, red_2, green_2, blue_2···)
Parameter		ch: Output channel 1 = OUT1 to 4 = OUT4
		ch_1-4: Output channel 0 = All outputs, 1 = OUT1 to 4 = OUT4
		red_1-4 : Background color (Red) green_1-4 : Background color (Green) blue_1-4 : Background color (Blue) 0 to 255 [Default] 255 (White) Getting commands: registered bitmap settings is returned in order.
		bitmap_1-4: Bitmap number 0 = All bitmaps, 1 = bitmap 1, 2 = bitmap 2, 3 = bitmap 3, 4 = bitmap 4 Only registered numbers can be specified.
Getting example	Command	@GBB,2
	Response	@GBB,2,255,0,0,255,0,0,255,0,0,255,0,0
	Description	Getting background color of OUT2. R: 255, G and B: 0 (Red)
Setting example	Command	@SBB,1,1,255,255,255
	Response	@SBB,1,1,255,255,255
	Description	Setting background color for when Bitmap 1 is output to OUT1 to 255 for RGB (white).
Remarks		—

<b>@GBT / @SBT</b>		<b>Aspect ratio</b>
Getting	Command	@GBT, ch
	Response	@GBT, ch, aspect_1, aspect_2, aspect_3, aspect_4
Setting	Command	@SBT, ch_1, bitmap_1, aspect_1 (, ch_2, bitmap_2, aspect_2···)
	Response	@SBT, ch_1, bitmap_1, aspect_1 (, ch_2, bitmap_2, aspect_2···)
Parameter		<p>ch: Output channel 1 = OUT1 to 4 = OUT4</p> <p>ch_1-4: Output channel 0 = All outputs, 1 = OUT1 to 4 = OUT4</p> <p>aspect_1-4: Aspect ratio 0 = AUTO [Default], 1 = FULL, 2 = THROUGH Getting commands: registered bitmap settings is returned in order.</p> <p>bitmap_1-4: Bitmap number 0 = All bitmaps, 1 = bitmap 1, 2 = bitmap 2, 3 = bitmap 3, 4 = bitmap 4 Only registered numbers can be specified.</p>
Getting example	Command	@GBT,1
	Response	@GBT,1,1,1,1,1
	Description	Getting aspect ratio of OUT1. Displayed on FULL screen.
Setting example	Command	@SBT,1,1,1
	Response	@SBT,1,1,1
	Description	Setting the aspect ratio of bitmap 1 that is output to OUT1 to FLL.
Remarks		—

<b>@GZP / @SZP</b>		<b>Display position</b>
Getting	Command	@GZP, ch
	Response	@GZP, ch, position_1, position_2, position_3, position_4
Setting	Command	@SZP, ch_1, bitmap_1, position_1 (, ch_2, bitmap_2, position_2····)
	Response	@SZP, ch_1, bitmap_1, position_1 (, ch_2, bitmap_2, position_2····)
Parameter		<p>ch: Output channel 1 = OUT1 to 4 = OUT4</p> <p>ch_1-4: Output channel 0 = All outputs, 1 = OUT1 to 4 = OUT4</p> <p>position_1-4: Display position 0 = CENTER [Default], 1 = TOP-LEFT, 2 = BOTTOM-LEFT, 3 = TOP-RIGHT, 4 = BOTTOM-RIGHT Getting commands: registered bitmap settings is returned in order.</p> <p>bitmap_1-4: Bitmap number 0 = All bitmaps, 1 = Bitmap 1, 2 = Bitmap 2, 3 = Bitmap 3, 4 = Bitmap 4 Only registered numbers can be specified.</p>
Getting example	Command	@GZP,1
	Response	@GZP,1,1,1,1,1
	Description	Getting the display position of OUT1. Displaying at TOP-LEFT.
Setting example	Command	@SZP,1,1,1
	Response	@SZP,1,1,1
	Description	Setting bitmap 1 that is output from OUT1 to be displayed at TOP-LEFT.
Remarks		—

<b>@GBA / @SBA</b>		<b>Assigning input channel</b>
Getting	Command	@GBA, ch <a href="#">↵</a>
	Response	@GBA, ch, bitmap_1, bitmap_2, bitmap_3, bitmap_4, ..., bitmap_8 <a href="#">↵</a>
Setting	Command	@SBA, ch_1, input_1, bitmap_1 (, ch_2, input_2, bitmap_2...) <a href="#">↵</a>
	Response	@SBA, ch_1, input_1, bitmap_1 (, ch_2, input_2, bitmap_2...) <a href="#">↵</a>
Parameter		<p>ch: Output channel 1 = OUT1 to 4 = OUT4</p> <p>ch_1-4: Output channel 0 = All outputs, 1 = OUT1 to 4 = OUT4</p> <p>bitmap_1-8: Bitmap assignment 0 = NONE [Default], 1 = Bitmap 1, 2 = Bitmap 2, 3 = Bitmap 3, 4 = Bitmap 4 Only registered numbers can be specified.</p> <p>input_1-8: Input channel 0 = All inputs, 1 = IN1 to 8 = IN8</p>
Getting example	Command	@GBA,1 <a href="#">↵</a>
	Response	@GBA,1,0,0,0,0,0,1,0 <a href="#">↵</a>
	Description	Getting the OUT1 bitmap assignment. OUT1: bitmap 1 to IN7, other input channels: no bitmap is assigned.
Setting example	Command	@SBA,1,7,1 <a href="#">↵</a>
	Response	@SBA,1,7,1 <a href="#">↵</a>
	Description	Setting OUT1: Assigning bitmap 1 to IN7 (If IN7 is selected, bitmap 1 is output.)
Remarks		—

<b>@GPB / @SPB</b>		<b>Startup bitmap</b>
Getting	Command	@GPB <a href="#">↵</a>
	Response	@GPB, out_1, out_2, out_3, out_4 <a href="#">↵</a>
Setting	Command	@SPB, ch_1, out_1 (, ch_2, out_2...) <a href="#">↵</a>
	Response	@SPB, ch_1, out_1 (, ch_2, out_2...) <a href="#">↵</a>
Parameter		<p>out_1-4: Outputting bitmap image 0 = OFF [Default], 1 = Bitmap 1 ON, 2 = Bitmap 2 ON, 3 = Bitmap 3 ON, 4 = Bitmap 4 ON Only registered numbers can be specified.</p> <p>ch_1-4: Output channel 0 = All outputs, 1 = OUT1 to 4 = OUT4</p>
Getting example	Command	@GPB <a href="#">↵</a>
	Response	@GPB,0,0,1,1 <a href="#">↵</a>
	Description	Getting the bitmap that is output at startup. Bitmap 1 is output to OUT3 and OUT4.
Setting example	Command	@SPB,1,0 <a href="#">↵</a>
	Response	@SPB,1,0 <a href="#">↵</a>
	Description	OUT1: not output a bitmap at startup.
Remarks		—

<b>@GBD / @SBD</b>		<b>Dividing memory area</b>
Getting	Command	@GBD
	Response	@GBD, num, block_1 (, block_2···)
Setting	Command	@SBD, num, mode (, block_1, block_2···)
	Response	@SBD, num, mode, block_1 (, block_2···)
Parameter		<p>num: The number of divides 1 to 4 [Default] 1</p> <p>block_1-4: Block size of each memory 0 to 128 [Default] 128 Specify and return the divided block size. 1 block: 65,536 bytes, the total size of all bitmaps: 128 blocks (8,388,608 bytes or smaller) Specify only if “3” is selected for the “mode” below. If you set the divide mode to “3”, specify this value.</p> <p>mode: Divide mode 0 = AUTO, 1 = RESIZE, 2 = FORCE, 3 = Specify size If you select “3”, set <i>size_1-4</i> below.</p>
Getting example	Command	@GBD
	Response	@GBD,2,64,64
	Description	Getting the divide setting for bitmap memory. Bitmap 1 and bitmap 2: 64 blocks (4,194,304 bytes) are allocated for each.
Setting example	Command	@SBD,2,1
	Response	@SBD,2,1,64,64
	Description	Dividing bitmap memory into two in RESIZE mode. Bitmap 1 and bitmap 2: 64 blocks (4,194,304 bytes) are allocated for each.
Remarks		—

<b>@GBV</b>		<b>Memory area status</b>
Getting	Command	@GBV
	Response	@GBV, num, block_1 (, block_2···)
Parameter		<p>num: The number of divides 1 to 4 [Default] 1</p> <p>block_1-4: Block size of each memory actually used. 0 to 128 [Default] 128</p>
Getting example	Command	@GBV
	Response	@GBV,2,32,0
	Description	Getting the actual status of bitmap memory. Bitmap 1: 32 blocks (2,097,152 bytes) are used, bitmap 2: not registered.
Remarks		—

<b>@GFZ / @SFZ</b>		<b>Freeze</b>
Getting	Command	@GFZ ↵
	Response	@GFZ, freeze_1, freeze_2, freeze_3, freeze_4 ↵
Setting	Command	@SFZ, ch_1, freeze_1 (, ch_2, freeze_2···) ↵
	Response	@SFZ, ch_1, freeze_1 (, ch_2, freeze_2···) ↵
Parameter		freeze_1-4: Setting freeze 0 = OFF [Default], 1 = ON
		ch_1-4: Output channel 0 = All outputs, 1 = OUT1 to 4 = OUT4
Getting example	Command	@GFZ ↵
	Response	@GFZ,1,0,0,0 ↵
	Description	Getting the freeze status. OUT1: input image is frozen and output.
Setting example	Command	@SFZ,1,1 ↵
	Response	@SFZ,1,1 ↵
	Description	Freezing the OUT1 image.
Remarks		Images freeze temporarily. When input channel is switched or input signal is changed, the freeze is released automatically and input image is output normally.

<b>@CAP</b>		<b>Capturing input image</b>
Setting	Command	@CAP, ch, bitmap ↵
	Response	@CAP, ch, bitmap ↵
Parameter		ch: Output channel 1 = OUT1 to 4 = OUT4
		bitmap: Bitmap number 1 = Bitmap 1,           2 = Bitmap 2, 3 = Bitmap 3,           4 = Bitmap 4 Only the number of divides or less value can be specified.
Setting example	Command	@CAP,1,2 ↵
	Response	@CAP,1,2 ↵
	Description	Registering OUT1 input video in bitmap 2.
Remarks		—

### 3.3.17 Other settings

<b>@GLS / @SLS</b>		<b>Operation lock</b>
Getting	Command	@GLS ↵
	Response	@GLS, lock ↵
Setting	Command	@SLS, lock ↵
	Response	@SLS, lock ↵
Parameter		lock: Operation lock 0 = Releasing lock [Default], 1 = Locking, 2 = Changing the current setting
Getting example	Command	@GLS ↵
	Response	@GLS,1 ↵
	Description	Getting the operation lock status. Front panel keys are locked.
Setting example	Command	@SLS,1 ↵
	Response	@SLS,1 ↵
	Description	Enabling operation lock.
Remarks		—

<b>@GLM / @SLM</b>		<b>Setting operation to be locked</b>
Getting	Command	@GLM ↵
	Response	@GLM, channel, menu, preset_load, command, power, out_select ↵
Setting	Command	@SLM, channel, menu, preset_load, command, power, out_select ↵
	Response	@SLM, channel, menu, preset_load, command, power, out_select ↵
Parameter		channel : Input channel selection key menu : Menu operation key preset_load : Preset load execution command : Control command execution power : Sink device power key out_select : Output channel switching key 0 = Not locked, 1 = Locked [Default]
Getting example	Command	@GLM ↵
	Response	@GLM,1,0,0,0,0,0 ↵
	Description	Getting the target keys/operations to be locked. Input channel selection keys are locked.
Setting example	Command	@SLM,1,0,0,0,0,0 ↵
	Response	@SLM,1,0,0,0,0,0 ↵
	Description	Setting input channel selection keys to be locked.
Remarks		Setting out_select to 0.

<b>@GBZ / @SBZ</b>		<b>Buzzer</b>
Getting	Command	@GBZ ↵
	Response	@GBZ, bz ↵
Setting	Command	@SBZ, bz ↵
	Response	@SBZ, bz ↵
Parameter		bz : Buzzer sound 0 = OFF, 1 = ON [Default]
Getting example	Command	@GBZ ↵
	Response	@GBZ,1 ↵
	Description	Getting the buzzer status. ON
Setting example	Command	@SBZ,1 ↵
	Response	@SBZ,1 ↵
	Description	Enabling buzzer.
Remarks		—

<b>@GHP / @SHP</b>		<b>Power supply of HDBaseT input</b>
Getting	Command	@GHP ↵
	Response	@GHP, mode_1, mode_2 ↵
Setting	Command	@SHP, ch_1, mode_1 (, ch_2, mode_2···) ↵
	Response	@SHP, ch_1, mode_1 (, ch_2, mode_2···) ↵
Parameter		ch_1-2: Input channel 5 = IN5, 6 = IN6
		mode_1-2: Power supply 0 = OFF [Default], 1 = ON
Getting example	Command	@GHP ↵
	Response	@GHP,0,0 ↵
	Description	Getting the power supply setting of HDBaseT input. Power supply of HDBaseT input is set to OFF.
Setting example	Command	@SHP,5,1 ↵
	Response	@SHP,5,1 ↵
	Description	Power supply of IN5 is set to ON.
Remarks		—

@GSS		I/O status												
Getting	Command	@GSS, channel, mode ↵												
	Response	@GSS, channel, mode, status_1 (, status_2···) ↵												
Parameter		<p>channel: I/O channel            1 = IN1 to 8 = IN8            11 = OUT1 to 14 = OUT4</p> <p>mode: Target status</p> <p>channel = 1 to 8 (Digital input channel):            0 = All of 1 to 4,            1 = Input signal type*1,            2 = Video input signal format*2,            3 = Audio input signal format*3,            4 = HDCP input*4</p> <p>channel = 7 to 8 (Analog input channel):            0 = 1 and 2,            1 = Input signal type*1,            2 = Video input signal format*2</p> <p>channel = 11 to 14 (Output channel):            0 = All of 1 to 3,            1 = HDCP authentication status*4,            2 = Output signal type*5,            3 = Error code*6</p> <p>status_1-4: Status</p> <p>*1 One of the following values is returned.</p> <table border="1"> <thead> <tr> <th>Value</th> <th>Input signal type</th> </tr> </thead> <tbody> <tr> <td>Hxx</td> <td>HDMI signal is input. xx stands for color depth which is 24 or 30.</td> </tr> <tr> <td>D</td> <td>DVI signal is input</td> </tr> <tr> <td>R</td> <td>Analog RGB signal is input</td> </tr> <tr> <td>Y</td> <td>Analog YPbPr signal is input</td> </tr> <tr> <td>N</td> <td>No signal is input</td> </tr> </tbody> </table>	Value	Input signal type	Hxx	HDMI signal is input. xx stands for color depth which is 24 or 30.	D	DVI signal is input	R	Analog RGB signal is input	Y	Analog YPbPr signal is input	N	No signal is input
Value	Input signal type													
Hxx	HDMI signal is input. xx stands for color depth which is 24 or 30.													
D	DVI signal is input													
R	Analog RGB signal is input													
Y	Analog YPbPr signal is input													
N	No signal is input													

@GSS	I/O status (cont'd)													
Parameter	*2 For format of video input signal.													
	<table border="1"> <thead> <tr> <th data-bbox="443 275 719 309">Reply example</th> <th data-bbox="726 275 1410 309">Format of video input signal</th> </tr> </thead> <tbody> <tr> <td data-bbox="443 318 719 376">1080i 59.94Hz</td> <td data-bbox="726 318 1410 376">SDTV/HDTV signal is input, which replies the format type and vertical synchronous frequency</td> </tr> <tr> <td data-bbox="443 385 719 465">800 x 600 60.00Hz</td> <td data-bbox="726 385 1410 465">RGB signal is input, and [Horizontal resolution x Vertical resolution and vertical synchronous frequency] is returned.</td> </tr> <tr> <td data-bbox="443 474 719 533">56.83kHz 60.02Hz</td> <td data-bbox="726 474 1410 533">Undetectable signal is input, which replies the horizontal and vertical synchronous frequencies.</td> </tr> <tr> <td data-bbox="443 542 719 573">NO SIGNAL</td> <td data-bbox="726 542 1410 573">No video signal is input</td> </tr> </tbody> </table>	Reply example	Format of video input signal	1080i 59.94Hz	SDTV/HDTV signal is input, which replies the format type and vertical synchronous frequency	800 x 600 60.00Hz	RGB signal is input, and [Horizontal resolution x Vertical resolution and vertical synchronous frequency] is returned.	56.83kHz 60.02Hz	Undetectable signal is input, which replies the horizontal and vertical synchronous frequencies.	NO SIGNAL	No video signal is input			
	Reply example	Format of video input signal												
	1080i 59.94Hz	SDTV/HDTV signal is input, which replies the format type and vertical synchronous frequency												
	800 x 600 60.00Hz	RGB signal is input, and [Horizontal resolution x Vertical resolution and vertical synchronous frequency] is returned.												
	56.83kHz 60.02Hz	Undetectable signal is input, which replies the horizontal and vertical synchronous frequencies.												
	NO SIGNAL	No video signal is input												
	*3 Format of audio input signal.													
	<table border="1"> <thead> <tr> <th data-bbox="443 654 719 687">Reply example</th> <th data-bbox="726 654 1410 687">Format of audio input signal</th> </tr> </thead> <tbody> <tr> <td data-bbox="443 696 719 754">LINEAR PCM 48kHz</td> <td data-bbox="726 696 1410 754">Linear PCM signal is input, which replies the sampling frequency.</td> </tr> <tr> <td data-bbox="443 763 719 844">LINEAR PCM 48kHz (MULTI CHANNEL)</td> <td data-bbox="726 763 1410 844">Multi channel linear PCM signal is input.</td> </tr> <tr> <td data-bbox="443 853 719 956">COMPRESSED AUDIO</td> <td data-bbox="726 853 1410 956">Compressed audio signal (such as Dolby Digital and DTS) is input (The MSD does not recognize detailed formats. "COMPRESSED AUDIO" is sent to all compressed audios).</td> </tr> <tr> <td data-bbox="443 965 719 999">NO SIGNAL</td> <td data-bbox="726 965 1410 999">No video signal is input.</td> </tr> </tbody> </table>	Reply example	Format of audio input signal	LINEAR PCM 48kHz	Linear PCM signal is input, which replies the sampling frequency.	LINEAR PCM 48kHz (MULTI CHANNEL)	Multi channel linear PCM signal is input.	COMPRESSED AUDIO	Compressed audio signal (such as Dolby Digital and DTS) is input (The MSD does not recognize detailed formats. "COMPRESSED AUDIO" is sent to all compressed audios).	NO SIGNAL	No video signal is input.			
	Reply example	Format of audio input signal												
	LINEAR PCM 48kHz	Linear PCM signal is input, which replies the sampling frequency.												
	LINEAR PCM 48kHz (MULTI CHANNEL)	Multi channel linear PCM signal is input.												
	COMPRESSED AUDIO	Compressed audio signal (such as Dolby Digital and DTS) is input (The MSD does not recognize detailed formats. "COMPRESSED AUDIO" is sent to all compressed audios).												
	NO SIGNAL	No video signal is input.												
	*4 HDCP authentication													
<table border="1"> <thead> <tr> <th data-bbox="443 1079 719 1113">Reply example</th> <th data-bbox="726 1079 1410 1113">HDCP authentication</th> </tr> </thead> <tbody> <tr> <td data-bbox="443 1122 719 1155">HDCP1.4 SUPPORT</td> <td data-bbox="726 1122 1410 1155">Device with HDCP 1.4 is connected.</td> </tr> <tr> <td data-bbox="443 1164 719 1245">HDCP NOT SUPPORT</td> <td data-bbox="726 1164 1410 1245">Device without HDCP is connected.</td> </tr> <tr> <td data-bbox="443 1254 719 1312">HDCP ERROR</td> <td data-bbox="726 1254 1410 1312">Device with HDCP is connected, but the authorization failed.</td> </tr> <tr> <td data-bbox="443 1321 719 1379">HDCP CHECK NOW</td> <td data-bbox="726 1321 1410 1379">Connection status of sink device was changed, and the status is being checked.</td> </tr> <tr> <td data-bbox="443 1388 719 1447">MONITOR DISCONNECT</td> <td data-bbox="726 1388 1410 1447">Sink device is disconnected.</td> </tr> <tr> <td data-bbox="443 1456 719 1482">UNCONNECTED</td> <td data-bbox="726 1456 1410 1482">Sink device is not connected.</td> </tr> </tbody> </table>	Reply example	HDCP authentication	HDCP1.4 SUPPORT	Device with HDCP 1.4 is connected.	HDCP NOT SUPPORT	Device without HDCP is connected.	HDCP ERROR	Device with HDCP is connected, but the authorization failed.	HDCP CHECK NOW	Connection status of sink device was changed, and the status is being checked.	MONITOR DISCONNECT	Sink device is disconnected.	UNCONNECTED	Sink device is not connected.
Reply example	HDCP authentication													
HDCP1.4 SUPPORT	Device with HDCP 1.4 is connected.													
HDCP NOT SUPPORT	Device without HDCP is connected.													
HDCP ERROR	Device with HDCP is connected, but the authorization failed.													
HDCP CHECK NOW	Connection status of sink device was changed, and the status is being checked.													
MONITOR DISCONNECT	Sink device is disconnected.													
UNCONNECTED	Sink device is not connected.													

@GSS	I/O status (cont'd)																																													
Parameter	<p data-bbox="411 241 694 271">*<sup>5</sup> Type of output signal.</p> <table border="1" data-bbox="443 275 1430 555"> <thead> <tr> <th data-bbox="451 275 592 353">Reply example</th> <th data-bbox="600 275 1430 353">Type of output signal</th> </tr> </thead> <tbody> <tr> <td data-bbox="451 356 592 394">Hxx</td> <td data-bbox="600 356 1430 394">HDMI signal is output. xx stands for the color depth, 24 or 30.</td> </tr> <tr> <td data-bbox="451 396 592 434">D</td> <td data-bbox="600 396 1430 434">DVI signal is input.</td> </tr> <tr> <td data-bbox="451 436 592 474">C</td> <td data-bbox="600 436 1430 474">HDCP is being authorized. No video is output.</td> </tr> <tr> <td data-bbox="451 477 592 515">N</td> <td data-bbox="600 477 1430 515">No sink device is connected.</td> </tr> <tr> <td data-bbox="451 517 592 555">O</td> <td data-bbox="600 517 1430 555">No twisted pair cable is connected.</td> </tr> </tbody> </table> <p data-bbox="411 600 1414 705">*<sup>6</sup> Error codes below are returned in the following order: video output to HDMI output connector / audio output to HDMI output connector / audio output to audio output connector.</p> <table border="1" data-bbox="443 710 1414 1697"> <thead> <tr> <th data-bbox="451 710 592 748">Error code</th> <th data-bbox="600 710 991 748">Video output status</th> <th data-bbox="999 710 1414 748">Audio output status</th> </tr> </thead> <tbody> <tr> <td data-bbox="451 750 592 788">0</td> <td colspan="2" data-bbox="600 750 1414 788">Video or audio is output correctly.*<sup>7</sup></td> </tr> <tr> <td data-bbox="451 790 592 875">1</td> <td data-bbox="600 790 991 875">—</td> <td data-bbox="999 790 1414 875">"@GAM / @SAM Audio output mute" is set to "ON".</td> </tr> <tr> <td data-bbox="451 878 592 992">2</td> <td colspan="2" data-bbox="600 878 1414 992">Only digital input is returned, which means DDC power is not input. (When no source device is connected, this error code is normally displayed.)</td> </tr> <tr> <td data-bbox="451 994 592 1032">3</td> <td data-bbox="600 994 991 1032">No video signal is input.</td> <td data-bbox="999 994 1414 1032">No audio signal is input.*<sup>7</sup></td> </tr> <tr> <td data-bbox="451 1034 592 1117">4</td> <td colspan="2" data-bbox="600 1034 1414 1117">Only digital input is returned, which means video or audio output of the source device is muted.</td> </tr> <tr> <td data-bbox="451 1120 592 1234">5</td> <td colspan="2" data-bbox="600 1120 1414 1234">Only digital input is returned, which means signal with HDCP is input but sink device is HDCP incompliant (This error code may be also returned during HDCP authentication)</td> </tr> <tr> <td data-bbox="451 1236 592 1350">6</td> <td colspan="2" data-bbox="600 1236 1414 1350">Only digital input is returned, which means source device does not output the returned information (packets) for output of video or audio.</td> </tr> <tr> <td data-bbox="451 1352 592 1503">7</td> <td data-bbox="600 1352 991 1503">Signal that is not supported by MSD series (dot clock is out of range) is input.</td> <td data-bbox="999 1352 1414 1503">Since compressed audio is input, audio cannot be output (Compressed audio can be output only to sink devices supporting compressed audio).</td> </tr> <tr> <td data-bbox="451 1505 592 1543">8</td> <td data-bbox="600 1505 991 1543">—</td> <td data-bbox="999 1505 1414 1543">—</td> </tr> <tr> <td data-bbox="451 1545 592 1697">9</td> <td data-bbox="600 1545 991 1697">—</td> <td data-bbox="999 1545 1414 1697">"@GDM / @SDM Output mode" is set to "DVI MODE" or a sink device that does not support audio is connected.*<sup>8</sup></td> </tr> </tbody> </table>	Reply example	Type of output signal	Hxx	HDMI signal is output. xx stands for the color depth, 24 or 30.	D	DVI signal is input.	C	HDCP is being authorized. No video is output.	N	No sink device is connected.	O	No twisted pair cable is connected.	Error code	Video output status	Audio output status	0	Video or audio is output correctly.* <sup>7</sup>		1	—	"@GAM / @SAM Audio output mute" is set to "ON".	2	Only digital input is returned, which means DDC power is not input. (When no source device is connected, this error code is normally displayed.)		3	No video signal is input.	No audio signal is input.* <sup>7</sup>	4	Only digital input is returned, which means video or audio output of the source device is muted.		5	Only digital input is returned, which means signal with HDCP is input but sink device is HDCP incompliant (This error code may be also returned during HDCP authentication)		6	Only digital input is returned, which means source device does not output the returned information (packets) for output of video or audio.		7	Signal that is not supported by MSD series (dot clock is out of range) is input.	Since compressed audio is input, audio cannot be output (Compressed audio can be output only to sink devices supporting compressed audio).	8	—	—	9	—	"@GDM / @SDM Output mode" is set to "DVI MODE" or a sink device that does not support audio is connected.* <sup>8</sup>
Reply example	Type of output signal																																													
Hxx	HDMI signal is output. xx stands for the color depth, 24 or 30.																																													
D	DVI signal is input.																																													
C	HDCP is being authorized. No video is output.																																													
N	No sink device is connected.																																													
O	No twisted pair cable is connected.																																													
Error code	Video output status	Audio output status																																												
0	Video or audio is output correctly.* <sup>7</sup>																																													
1	—	"@GAM / @SAM Audio output mute" is set to "ON".																																												
2	Only digital input is returned, which means DDC power is not input. (When no source device is connected, this error code is normally displayed.)																																													
3	No video signal is input.	No audio signal is input.* <sup>7</sup>																																												
4	Only digital input is returned, which means video or audio output of the source device is muted.																																													
5	Only digital input is returned, which means signal with HDCP is input but sink device is HDCP incompliant (This error code may be also returned during HDCP authentication)																																													
6	Only digital input is returned, which means source device does not output the returned information (packets) for output of video or audio.																																													
7	Signal that is not supported by MSD series (dot clock is out of range) is input.	Since compressed audio is input, audio cannot be output (Compressed audio can be output only to sink devices supporting compressed audio).																																												
8	—	—																																												
9	—	"@GDM / @SDM Output mode" is set to "DVI MODE" or a sink device that does not support audio is connected.* <sup>8</sup>																																												

@GSS		I/O status (cont'd)															
Parameter		<table border="1"> <thead> <tr> <th>Error code</th> <th>Video output status</th> <th>Audio output status</th> </tr> </thead> <tbody> <tr> <td>A</td> <td colspan="2">Input channel is set to "OFF". (@GSW / @SSW <b>Switching video and audio channel simultaneously,</b> @GSV / @SSVSwitching video channel, @GSA / @SSASwitching audio channel,)</td> </tr> <tr> <td>B</td> <td colspan="2">No sink device is connected.</td> </tr> <tr> <td>C</td> <td colspan="2">HDCP is being authorized.</td> </tr> <tr> <td>D</td> <td colspan="2">HDCP authentication failed.</td> </tr> </tbody> </table> <p><sup>*7</sup> Analog audio input status cannot be detected. Even if "0" is returned, audio may not be output with analog input selected.</p>	Error code	Video output status	Audio output status	A	Input channel is set to "OFF". (@GSW / @SSW <b>Switching video and audio channel simultaneously,</b> @GSV / @SSVSwitching video channel, @GSA / @SSASwitching audio channel,)		B	No sink device is connected.		C	HDCP is being authorized.		D	HDCP authentication failed.	
Error code	Video output status	Audio output status															
A	Input channel is set to "OFF". (@GSW / @SSW <b>Switching video and audio channel simultaneously,</b> @GSV / @SSVSwitching video channel, @GSA / @SSASwitching audio channel,)																
B	No sink device is connected.																
C	HDCP is being authorized.																
D	HDCP authentication failed.																
Getting example	Command	@GSS,1,0 ↵															
	Response	@GSS,1,0,H30,1080P 60Hz,LINEAR PCM 48kHz,HDCP ON ↵															
	Description	Getting IN1 all statuses. <ul style="list-style-type: none"> <li>• Input signal type: 30-BIT COLOR HDMI signal</li> <li>• Video input signal: 1080P 60Hz</li> <li>• Audio input signal: LINEAR PCM 48kHz</li> <li>• HDCP: ON</li> </ul>															
Remarks		—															

<b>@GES</b>		<b>Monitor's EDID</b>
Getting	Command	@GES, channel, mode
	Response	@GES, channel, mode, status_1 (, status_2, status_3···)
Parameter		<p>channel: Output connector 1 = OUT1 to 8 = OUT8</p> <p>mode: Statuses to be gotten 0 = All of 1 to 4, 1 = Monitor's name, 2 = Resolution and dot clock, 3 = HDMI support status, sampling structure, and color depth<sup>*1</sup>, 4 = Audio support status and sampling frequency, bit length, the number of channels, and support status of compressed audio <sup>*2</sup></p> <p>status_1-4: Status</p> <p><sup>*1</sup> For sink device that does not support HDMI, "DVI" is returned. For sink device that supports HDMI, "HDMI" is returned, and then supported sampling structures (RGB, YCbCr 4: 2: 2, YCbCr 4: 4: 4, and YCbCr 4: 2: 0, separated with "/") and supported color depths (24, 30, and 36, separated with "/") are replied in that order.</p> <p><sup>*2</sup> For sink device that does not support audio, "AUDIO NOT SUPPORT" is returned. For sink device that supports audio, "LINEAR PCM" is returned, and then supported sampling frequencies (32, 44.1, 48, 88.2, 96, 176.4, and 192, separated with "/"), bit length (16, 20, and 24, separated with "/"), the number of channels (one of 1 to 8), and "COMPRESSED AUDIO SUPPORT" (if compressed audio is supported) are replied in that order.</p>
Getting example	Command	@GES,1,0
	Response	@GES,1,0,MSD-6204,1920x1080 148.50MHz,DVI,AUDIO NOT SUPPORT
	Description	<p>Getting the EDID of the sink device connected to OUT1.</p> <ul style="list-style-type: none"> <li>• Monitor name: MSD-6204</li> <li>• Resolution: 1920x1080</li> <li>• Dot clock: 148.50 MHz</li> <li>• HDMI: Not supported</li> <li>• Audio: Not supported</li> </ul>
Remarks		—

<b>@GIV</b>		<b>Version</b>
Getting	Command	@GIV
	Response	@GIV, id, ver
Parameter		<p>id : Model number ver : Firmware version</p>
Getting example	Command	@GIV
	Response	@GIV,MSD-6204,1.00
	Description	<p>Getting the product information. Model number and firmware version are replied.</p>
Remarks		—

---

## User Guide (Command Guide) of MSD-62 Series

Ver.1.4.0

Issued on: 9 January 2026

---



<b>Headquarters</b>	IDK Corporation 7-9-1 Chuo, Yamato-shi, Kanagawa-pref. 242-0021 JAPAN TEL: +81-46-200-0764 FAX: +81-46-200-0765
<b>Email:</b> <a href="mailto:idk_eng@idk.co.jp">idk_eng@idk.co.jp</a>	<b>URL:</b> <a href="http://www.idkav.com">www.idkav.com</a>
<b>USA</b>	IDK America Inc. 72 Grays Bridge Road Suite 1-C, Brookfield, CT 06804 TEL: +1-203-204-2445
<b>Email:</b> <a href="mailto:sales@idkav.com">sales@idkav.com</a>	<b>URL:</b> <a href="http://www.idkav.com">www.idkav.com</a>
<b>Europe</b>	IDK Europe GmbH Lise-Meitner-Str. 6, D-40878 Ratingen TEL: +49-2102-578-301-0
<b>Email:</b> <a href="mailto:info@idkav.eu">info@idkav.eu</a>	<b>URL:</b> <a href="http://www.idkav.com">www.idkav.com</a>



<b>Product information Support</b>	Arvanics Corporation 7-9-1 Chuo, Yamato-shi, Kanagawa-pref. 242-0021 JAPAN TEL: +81-46-259-6920 FAX: +81-46-259-6930
<b>Email:</b> <a href="mailto:info@arvanics.com">info@arvanics.com</a>	<b>URL:</b> <a href="http://www.arvanics.com">www.arvanics.com</a>

Information in this document is subject to change without notice.

©2018 IDK Corporation, all rights reserved. All trademarks mentioned are the property of their respective owners.