

Digital Multi Switcher

MSD-62 Series

MSD-6203/MSD-6204

<User Guide>

Ver.2.7.0

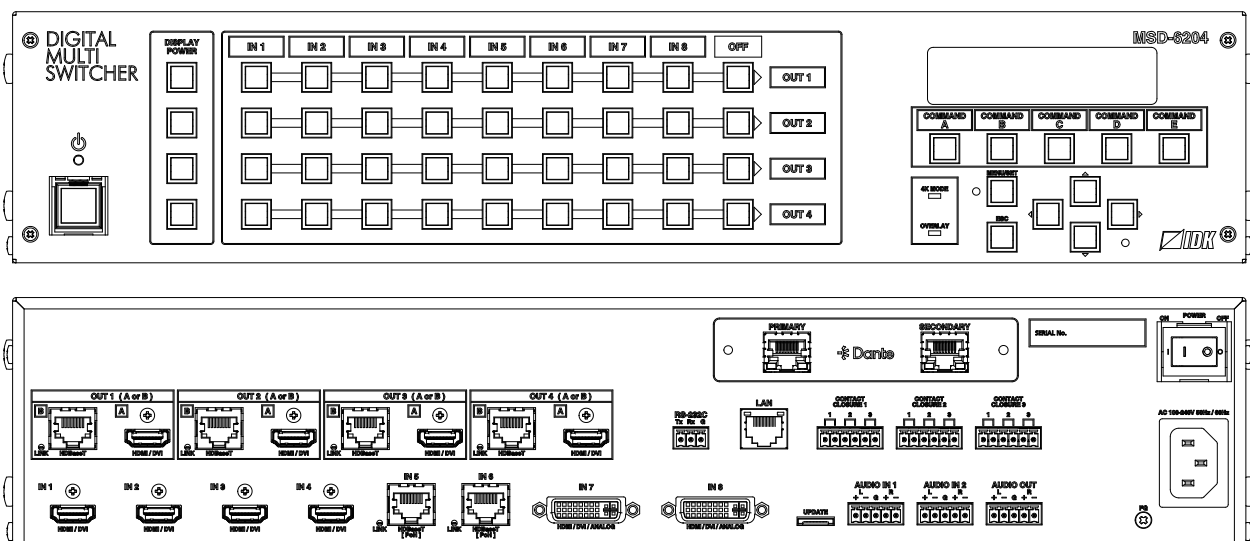

- Thank you for choosing our product.
- To ensure the best performance of this product, please read this user guide fully and carefully before using it and keep this manual together with the product for future reference as needed.

Trademarks

- HDBaseT™ and the HDBaseT Alliance Logo are trademarks of the HDBaseT Alliance.
- The terms HDMI and HDMI High-Definition Multimedia Interface, and the HDMI Logo are trademarks or registered trademarks of HDMI Licensing Administrator, Inc. in the United States and other countries.
- SDVoE™ and SDVoE logo are trademarks of SDVoE Alliance.
- Audinate® is a registered trademark of Audinate Pty Ltd. Dante® is a registered trademark of Audinate Pty Ltd.
- All other company and product names mentioned in this document are either registered trademarks or trademarks of their respective owners. In this document, the “®” or “™” marks may not be specified.
- ©2018 IDK Corporation, all rights reserved.

Before reading this manual

- All rights reserved.
- Some information contained in this User guide such as exact product appearance, diagrams, menu operations, and so on may differ depending on the product version.
- This User guide is subject to change without notice. You can download the latest version from IDK's website at: www.idkav.com

The reference manual consists of the following two volumes:

- User guide (this document):
Provides explanations and procedures for operations, installation, connections among devices, I/O adjustment and settings.
- Command guide: Please download the command guide from the website above.
Provides explanations and procedures for external control using RS-232C and LAN communications.

FCC STATEMENT

Note: This equipment has been tested and found to comply with the limits for a Class A digital device, pursuant to part 15 of the FCC Rules. These limits are designed to provide reasonable protection against harmful interference when the equipment is operated in a commercial environment. This equipment generates, uses, and can radiate radio frequency energy and, if not installed and used in accordance with the instruction manual, may cause harmful interference to radio communications. Operation of this equipment in a residential area is likely to cause harmful interference, in which case the user will be required to correct the interference at his own expense.

(Class A)

**Supplier's Declaration of Conformity
47 CFR § 2.1077 Compliance Information**

Unique Identifier

Type of Equipment: Digital Multi Switcher

Model Name: MSD-6203, MSD-6204

Responsible Party – U.S. Contact Information

Company Name: IDK America Inc.

Address: 72 Grays Bridge Road Suite 1-C, Brookfield, CT 06804

Telephone number: +1-203-204-2445

URL: www.idkav.com

FCC Compliance Statement

This device complies with Part 15 of the FCC Rules. Operation is subject to the following two conditions: (1) This device may not cause harmful interference, and (2) this device must accept any interference received, including interference that may cause undesired operation.

(FCC SDoC)

CE MARKING

This equipment complies with the essential requirements of the relevant European health, safety and environmental protection legislation.

WEEE MARKING



Waste Electrical and Electronic Equipment (WEEE), Directive 2002/96/EC
(This directive is only valid in the EU.)



This equipment complies with the WEEE Directive (2002/96/EC) marking requirement.







The left marking indicates that you must not discard this electrical/electronic equipment in domestic household waste.

Safety Instructions

Read all safety and operating instructions before using this product. Follow instructions and heed warnings/cautions.

Instructions and warnings/cautions for all products are provided. Some of them may not be applicable to your product.

	Warning	Indicates the presence of a hazard that may result in death or serious personal injury if the warning is ignored or the product is handled incorrectly.
	Caution	Indicates the presence of a hazard that may cause minor personal injury or property damage if the caution is ignored or the product is handled incorrectly.

Symbol	Description	Example
 Caution	This symbol is intended to alert the user. (Warning and caution)	 Hot surfaces Caution
 Prohibited	This symbol is intended to prohibit the user from specified actions.	 Do not disassemble
 Instruction	This symbol is intended to instruct the user.	 Unplug

Warning

For lifting heavy products:

 Instruction	<ul style="list-style-type: none"> • Lifting must be done by two or more personnel. <p>To avoid injury: When lifting the product, bend your knees, keep your back straight and get close to it with two or more persons.</p>
--	--





For installing and connecting products:

 Prohibited	<ul style="list-style-type: none"> • Do not place the product in unstable place. <p>Install the product in a horizontal and stable place, as this may fall or tip over and cause injury.</p> <ul style="list-style-type: none"> • Secure the product if installing in the locations with vibration. <p>Vibration may move or tip over the product unexpectedly, resulting in injury.</p>
---	--

Warning

 Instruction	<ul style="list-style-type: none"> ● Installation work must be performed by professionals. The product is intended to be installed by skilled technicians. For installation, please contact a system integrator or IDK. Improper installation may lead to the risk of fire, electric shock, injury, or property damage. ● Insert the power plug into an outlet that is unobstructed. Unobstructed access to the plug enables unplugging the product in case of any extraordinary failure, abnormal situation or for easy disconnection during extended periods of non-use. ● Insert the power plug into an appropriate outlet completely. If the plug is partially inserted, arcing may cause the connection to overheat, increasing the risk of electric shock or fire. Do not use a damaged plug or connect to a loose outlet. ● Unplug the product from an AC power source during installation or service. When connecting peripheral devices to this product, unplug all involved devices from outlets. Ground potential differences may cause fire or other difficulties. ● The product must be electrically earthed/grounded. To reduce the risk of electric shock, ensure the product is connected to a mains socket outlet with a protective earthing connection. ● For powering/powered functions, compatible cables must be used. Otherwise, it may cause problems or a fire.
---	---

For operating products:

 Prohibited	<ul style="list-style-type: none"> ● Keep out any foreign objects. To avoid fire or electric shock, do not permit foreign objects, such as metal and paper, to enter the product from vent holes or other apertures. ● For power cables/plugs, AC adapters, and cables for powering/powered functions, <ul style="list-style-type: none"> • Do not scratch, heat, or modify, including splicing or lengthening them. • Do not pull, place heavy objects on them, or pinch them. • Do not bend, twist, tie or clamp them together forcefully. <p>Misuse of the power cable and plug may cause fire or electric shock. If power cables/plugs become damaged, contact your IDK representative.</p>
 Do not disassemble	<ul style="list-style-type: none"> ● Do not repair, modify or disassemble. Since the product includes circuitry that uses potentially lethal, high voltage levels, disassembly by unauthorized personnel may lead to the risk of fire or electric shock. For internal inspection or repair, contact your IDK representative.
 Do not touch	<ul style="list-style-type: none"> ● Do not touch the product and connected cables during electric storms. Contact may cause electric shock.
 Instruction	<ul style="list-style-type: none"> ● Clean the power plug regularly. If the plug is covered in dust, it may increase the risk of fire.



If the following problem occurs:

 Unplug	<ul style="list-style-type: none"> ● Unplug immediately if the product smokes, makes unusual noise, or produces a burning odor. ● Unplug immediately if the product is damaged by falling or having been dropped. ● Unplug immediately if water or other objects are directed inside. <p>If you continue to use the product under these conditions, it may increase the risk of electric shock or fire. For maintenance and repair, contact your IDK representative.</p>
--	--



Caution

For installing and connecting products:

 <p>Prohibited</p>	<ul style="list-style-type: none"> ● Do not place the product in a location where it will be subjected to high temperatures. If the product is subjected to direct sunlight or high temperatures while under operation, it may affect the product's performance and reliability and may increase the risk of fire. ● Do not store or operate the product in dusty, oil smoke filled, or humid place. Placing the product in such environment may increase the risk of fire or electric shock. ● Do not block the vent holes. If ventilation slots are blocked, it may cause the product to overheat, affecting performance and reliability and may increase the risk of fire. ● Do not place or stack heavy items on the product. Failure to observe this precaution may result in damage to the product itself as well as other property and may lead to the risk of personal injury. ● Do not exceed ratings of outlet and wiring devices. Exceeding the rating of an outlet may increase the risk of fire and electric shock.
 <p>No wet hands</p>	<ul style="list-style-type: none"> ● Do not handle power plug with wet hands. Failure to observe this precaution may increase the risk of electric shock.
 <p>Instruction</p>	<ul style="list-style-type: none"> ● Use and store the product within the specified temperature/humidity range. If the product is used outside the specified range of temperature and humidity continuously, it may increase the risk of fire or electric shock. ● Do not place the product at elevations of 1.24 mi. (2,000 m) or higher above sea level. Failure to do so may shorten the life of the internal parts and result in malfunctions. ● When mounting the product into the rack, provide sufficient cooling space. Mount the product in a rack meeting EIA standards, and maintain spaces above and below for air circulation. For your safety as required, attach an L-shaped bracket in addition to the panel mount bracket kit to improve mechanical stability. ● Never insert screws without the rubber feet into the threaded holes on the bottom of the product. Never insert screws alone into the threaded holes on the bottom of the product. Doing so may lead to damage when the screws contact electric circuitry or components inside the product. Reinstall the originally supplied rubber feet using the originally supplied screws only.

For operating products:





 <p>Hot surfaces Caution</p>	<p>For products with the hot surfaces caution label only:</p> <ul style="list-style-type: none"> ● Do not touch the product’s hot surface. <p>If the product is installed without enough space, it may cause malfunction of other products. If you touch product’s hot surface, it may cause burns.</p>
 <p>Prohibited</p>	<ul style="list-style-type: none"> ● Use only the supplied power cable and AC adapter. ● Do not use the supplied power cable and AC adapter with other products. <p>If non-compliant adapter or power cables are used, it may increase the risk of fire or electric shock.</p>
 <p>Unplug</p>	<ul style="list-style-type: none"> ● If the product won’t be used for an extended period of time, unplug it. <p>Failure to observe this precaution may increase the risk of fire.</p> <ul style="list-style-type: none"> ● Unplug the product before cleaning. <p>To prevent electric shock.</p>
 <p>Instruction</p>	<ul style="list-style-type: none"> ● Do not prevent heat release. <p>If cooling fan stops, power off the product and contact IDK. Failure to do so may raise internal temperature and increase the risk of malfunction, fire, or electric shock.</p> <ul style="list-style-type: none"> ● Keep vents clear of dust. <p>If the vent holes near the cooling fan or near the fan are covered with dust, internal temperatures increase and may increase the risk of malfunction. Clean the vent holes and near the fan as needed. If dust accumulates inside of the product, it may increase the risk of fire or electric shock. Periodic internal cleaning, especially before humid rainy season, is recommended. For internal cleaning, contact your IDK representative.</p>

Table of Contents

1	About this Guide	13
2	Included items	14
3	Product outline	15
4	Features	16
5	Panels	17
5.1	Front panel	17
5.2	Rear panel	18
6	System Configuration Example	20
7	Precautions	23
7.1	Installation	23
7.2	Cabling	24
7.2.1	Cables	25
7.2.2	DVI-I input connector	25
7.2.3	Twisted pair cable for extension	27
7.2.4	Connecting audio cable	28
7.2.5	Connecting RS-232C cable	28
7.2.6	Contact closure	29
8	Basic Operation	30
8.1	Main power switch and standby key	30
8.1.1	Power up period	30
8.2	Selecting input channels	31
8.3	Video processing mode	32
8.3.1	Normal mode	32
8.3.2	Video combination mode	32
8.3.3	4K mode	35
8.4	Menu operation	37
8.5	Sink device power control	38
8.6	Command control	38
8.7	Locking and unlocking key function	39
8.8	Dante output (Optional)	40
8.8.1	IP network connection	41
8.8.2	Dante Controller	42
8.9	Initialization	43
8.10	Control from WEB browser	56
9	Menu	57
9.1	Menu list	57
9.2	Input signal automatic detection	60
9.3	Operation from front panel	62
9.3.1	Channel switching mode	62
9.3.2	Control command execution key operation	62
9.4	Setting position, size, and masking	63
9.4.1	Output resolution	63
9.4.2	Aspect ratio for sink device	64
9.4.3	Aspect ratio	64
9.4.4	Aspect ratio control	65
9.4.5	Overscan	65
9.4.6	Display position	65

9.4.7	Display size	66
9.4.8	Masking	67
9.4.9	Automatic sizing	67
9.4.10	Background color	68
9.4.11	Test pattern	68
9.5	Video processing setting	69
9.5.1	Video output mode	69
9.5.2	Window setting [OVERLAY mode]	69
9.5.3	Window layer order [OVERLAY mode]	70
9.5.4	Horizontal flip [OFF / OVERLAY mode]	71
9.5.5	Window hiding	71
9.6	Quality setting	72
9.6.1	Sharpness	72
9.6.2	Brightness	72
9.6.3	Contrast	72
9.6.4	HUE	73
9.6.5	Saturation	73
9.6.6	Black level	73
9.6.7	Gamma	73
9.6.8	Default color	74
9.7	Input settings	75
9.7.1	No-signal input monitoring	75
9.7.2	HDCP input setting	76
9.7.3	Analog input signal parameters	77
9.7.4	Automatic detection of video input interruption	78
9.7.5	Selecting signal of DVI input connector	78
9.7.6	HDBaseT input long reach mode	78
9.7.7	Fixing settings for each input signal	79
9.8	Setting input timing	80
9.8.1	Automatic measurement	81
9.8.2	The total number of horizontal dots	83
9.8.3	Start position	83
9.8.4	Active area	84
9.8.5	Automatic measurement of start position	85
9.8.6	Automatic setting of input timing	85
9.8.7	Loading device data	86
9.8.8	Registering device data	86
9.8.9	Tracking	86
9.9	Output settings	87
9.9.1	Output equalizer	87
9.9.2	Output mode	87
9.9.3	Synchronous signal output with no input video	88
9.9.4	Output video with no input video	88
9.9.5	Window transition effect	89
9.9.6	Window transition speed	89
9.9.7	Wipe color	89
9.9.8	Output connector	90
9.9.9	HDCP output	90
9.9.10	The number of HDCP retries	91
9.9.11	Deep Color	91

9.9.12	CEC connection	92
9.9.13	HDCP re-authentication	92
9.9.14	Priority of input channel automatic switching	93
9.9.15	Ignoring duration after automatic switching	95
9.9.16	Channel switching mode of automatic switching	95
9.9.17	HDBaseT output long reach mode.....	95
9.10	Audio setting	96
9.10.1	Output level	97
9.10.2	Output mute.....	97
9.10.3	Selecting audio input.....	97
9.10.4	Audio input level.....	97
9.10.5	Lip sync	98
9.10.6	Sampling frequency	98
9.10.7	Analog audio output connector	99
9.10.8	Multi-channel audio output.....	99
9.10.9	Test tone	100
9.11	EDID (Extended Display Identification Data).....	101
9.11.1	EDID.....	101
9.11.2	Resolutions for PCs	102
9.11.3	Input resolution for AV devices	104
9.11.4	Deep Color	105
9.11.5	Audio format.....	105
9.11.6	Speaker configuration	106
9.11.7	Copying EDID.....	107
9.12	RS-232C	108
9.12.1	RS-232C communication setting.....	108
9.12.2	RS-232C operation mode	108
9.12.3	RS-232C HDBaseT connection	109
9.12.4	RS-232C transmitting channel	109
9.12.5	RS-232C receiving channel	109
9.13	LAN	110
9.13.1	IP address/Subnet mask/Gateway address.....	111
9.13.2	LAN operation mode	112
9.13.3	TCP port number.....	113
9.13.4	MAC address.....	113
9.13.5	Setting HDBaseT LAN	113
9.14	Setting control command	114
9.14.1	Registering/editing control command.....	116
9.14.2	Registering/Editing reply command	121
9.14.3	Command link	124
9.14.4	Command execution	126
9.14.5	Invalid duration at control command execution.....	126
9.14.6	Initializing registered command and link	126
9.14.7	Command execution key: Illuminating condition.....	127
9.14.8	Blinking at command execution key.....	127
9.15	Preset memory.....	128
9.15.1	Recalling crosspoint	128
9.15.2	Saving crosspoint.....	128
9.15.3	Editing crosspoint.....	129
9.15.4	Recalling all settings	129

9.15.5	Saving all settings	130
9.15.6	Copying output setting	131
9.15.7	Start-up setting	132
9.16	Bitmap setting	133
9.16.1	Sending bitmap file	133
9.16.2	Outputting bitmap image	135
9.16.3	Background color	135
9.16.4	Aspect ratio	135
9.16.5	Display position	136
9.16.6	Assigning input channel	136
9.16.7	Startup bitmap output	136
9.16.8	Dividing memory area	137
9.16.9	Input image capture	139
9.17	Startup setting	141
9.17.1	Power state	141
9.17.2	DISPLAY POWER keys	142
9.17.3	Control command execution key	143
9.17.4	Key function lock	144
9.18	Other settings	145
9.18.1	Grouping key function lock	145
9.18.2	Beep	145
9.18.3	Automatic lock of control command execution key	145
9.18.4	Power saving	146
9.18.5	DISPLAY POWER key pressing duration	146
9.18.6	HDBaseT input power supply	146
9.18.7	Input channel automatic linking	147
9.18.8	Top page	148
9.18.9	Input signal status	149
9.18.10	Sink device status	151
9.18.11	Viewing sink device EDID	153
9.18.12	Viewing version information	154
9.19	Setting DANTE (Optional)	155
9.19.1	CH61-CH64	155
10	Product specification	156
11	Troubleshooting	160

1 About this Guide

This user guide explains how to use the MSD-62 series switchers (hereafter referred to as “MSD”). All MSD series switchers include scan conversion and the models are generally divided into two versions, based on the number of outputs. Since descriptions in this document are for MSD-6204, there may be slight differences between these models and other MSD models.

[Table 1.1] MSD-62 series products

Model	Input	Output
MSD-6203	8 inputs	3 outputs
MSD-6204		4 outputs

[See: 5.2 Rear panel]

2 Included items

Ensure that all items illustrated below are included in the package.

If any items are missing or damaged, please contact IDK.

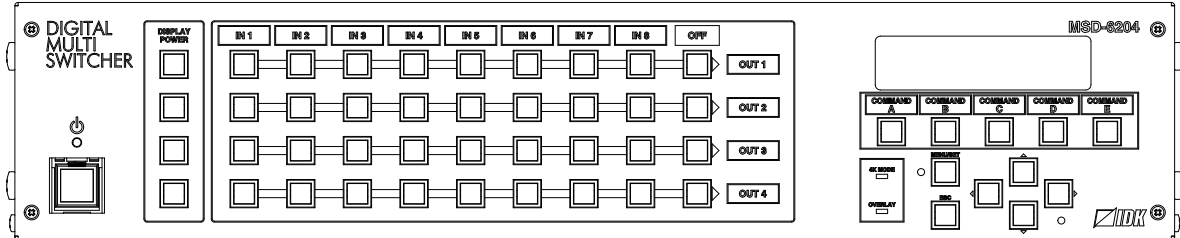

One (1) main unit (Figure: MSD-6204)

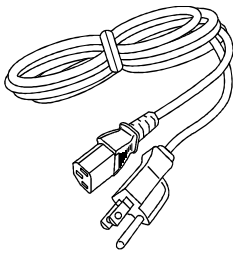

One (1) power cord, 6 ft. (1.8 m)

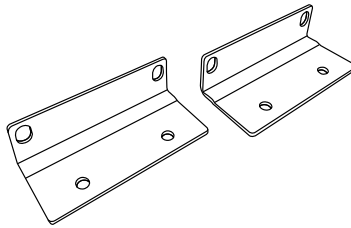

Two (2) rack mounting brackets

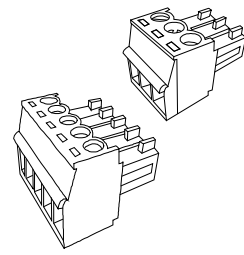

One (1) 3-position terminal block
Three (3) 5-position terminal blocks

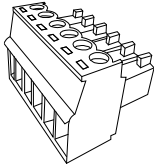

Three (3) 6-position terminal blocks

[Fig. 2.1] Included items

3 Product outline

Models within the MSD-62 series are high performance, digital presentation switchers with built-in scan converters.

The following input signal formats are supported: HDMI, DVI, analog RGB/HV, and analog YPbPr. All video signal inputs are converted to HDMI signals and output at user definable resolution formats up to 4K@30.

For audio input and output, digital audio and analog audio formats are supported, and they are cross-routable. Audio levels of each input and output can be set individually. The lip sync feature provides the user with a means to control time alignment between the video and audio.

The MSD series switchers may be configured and controlled remotely via RS-232C or TCP/IP (LAN). Additionally, peripheral devices connected to the MSD can be controlled through RS-232C, LAN, CEC, or contact closure by registering external device control commands. The waiting function can delay the issuance of registered commands to peripheral equipment. As an example, a power down command can be delayed until after sufficient lamp cooling time for a projector has elapsed. Control commands can be initiated from front panel keys or in response to commands that are issued to the MSD via RS-232C or LAN. Commands can also be initiated when specified channel selection keys are operated or the MSD is powered ON.

With Dante (optional), up to 64 audio channels (48 kHz) can be transmitted over one LAN cable.

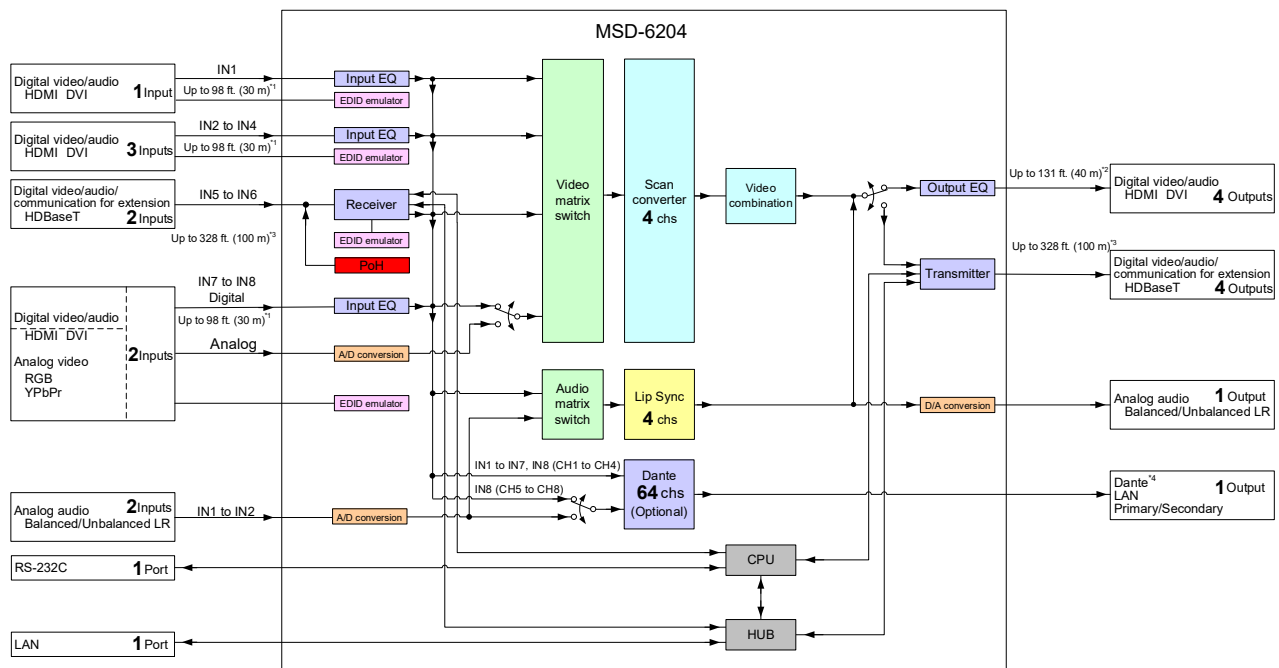

¹ Maximum transmission distances
Up to 98 ft. (30 m) : 1080p@60
Up to 66 ft. (20 m) : 4K@30 (IN1 only)

² Maximum transmission distances
Up to 131 ft. (40 m) : 1080p@60
Up to 98 ft. (30 m) : 4K@30

³ Maximum transmission distances
Up to 328 ft. (100 m) : 4K@30
Up to 492 ft. (150 m) : 1080p (24 bit) in Long reach mode
For long reach mode, video signals up to 1080p (24 bit) can be transmitted to 492 ft. (150 m) at maximum if using with IDK's HDBaseT products supporting 328 ft. (100 m) transmission.

⁴ Dante output is optional.

[Fig. 3.1] MSD-6204 diagram

4 Features

■ Video

- Up to 4K@30
- Automatic input signal equalization
 - Input Up to 98 ft. (30 m) : 1080p@60, Up to 66 ft. (20 m) : 4K@30
 - Output Up to 131 ft. (40 m) : 1080p@60, Up to 98 ft. (30 m) : 4K@30
- Motion adaptive interlaced/progressive conversion
- Scan conversion
- Aspect ratio control
- Horizontal flip (4K format is not supported)
- Seamless switching with one black frame
- Analog/Digital conversion
- Anti-snow
- Up to 492 ft. (150 m) over Cat6 cable in Long reach mode*¹

■ Audio

- Embedding/De-embedding
- Volume adjustment (Input/Output)
- Lip Sync
- Dante output (Optional)

■ Video combination (4K format is not supported)

- Simultaneous display of up to 4 input images on a screen
- Window display priority setting
- Window displaying/hiding

■ Control input

- RS-232C
- LAN

■ Control output

- Control command output (e.g. controlling projectors)
- PJLink
- CEC (Control sink device power)
- Contact closure

■ Others

- PoH (HDBaseT input)
- EDID emulation
- All functions and configuration settings accessible through browser
- Input channel automatic switching
- Audio breakaway for independent audio and video switching
- Crosspoint memory
- Preset memory
- Last memory
- Connection Reset
- Front key function lock

*¹ For long reach mode, video signals up to 1080p (24 bit) can be transmitted to 492 ft. (150 m) at maximum if the MSD is used with IDK's HDBaseT transmitter or receiver that supports 328 ft. (100 m) extension.

5 Panels

5.1 Front panel

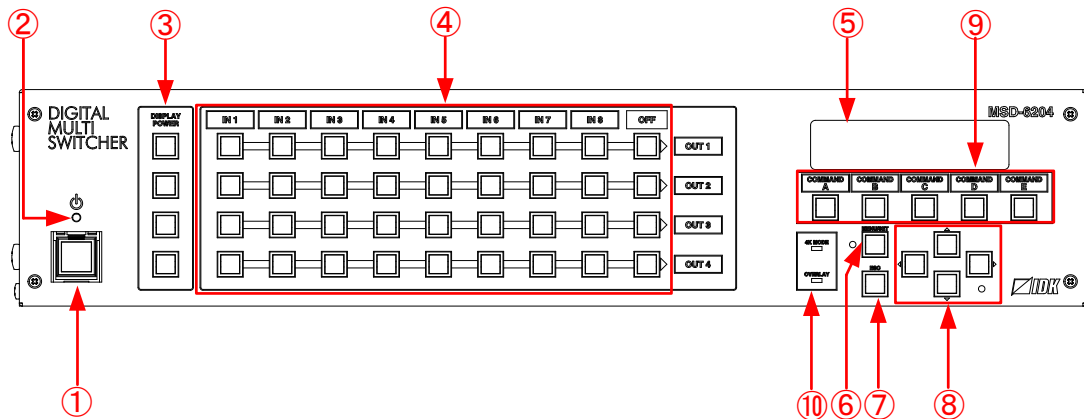

[Fig. 5.1] Front panel drawing (MSD-6204)

[Table 5.1] Front panel features

#	Feature	Description
①	Standby switch	Standby or powers on the MSD. 【See: 8.1 Main power switch and standby key】
②	Power LED	Shows power status of the MSD. 【See: 8.1 Main power switch and standby key】
③	DISPLAY POWER keys	Power on/off connected sink devices. 【See: 8.5 Sink device power control】
④	Input channel selection keys	Select input channels. 【See: 8.2 Selecting input channels】
⑤	VFD screen	Displays menus and settings.
⑥	MENU/SET key	Selects menus, edits, controls, and saves settings. 【See: 8.4 Menu operation】
⑦	ESC key	Ends the current menu setting.
⑧	Arrow keys (▲, ▼, ◀, ▶)	Navigate menu, move cursor, and change setting values.
⑨	Control command execution keys	Execute control commands or crosspoint memory. 【See: 9.14 Setting control command】 【See: 9.15 Preset memory】
⑩	Video mode LEDs (4K MODE/OVER LAY)	Show video processing mode. Illuminates when 4K MODE or OVERLAY mode (video combination mode) is selected. 【See: 8.3 Video processing mode】

5.2 Rear panel

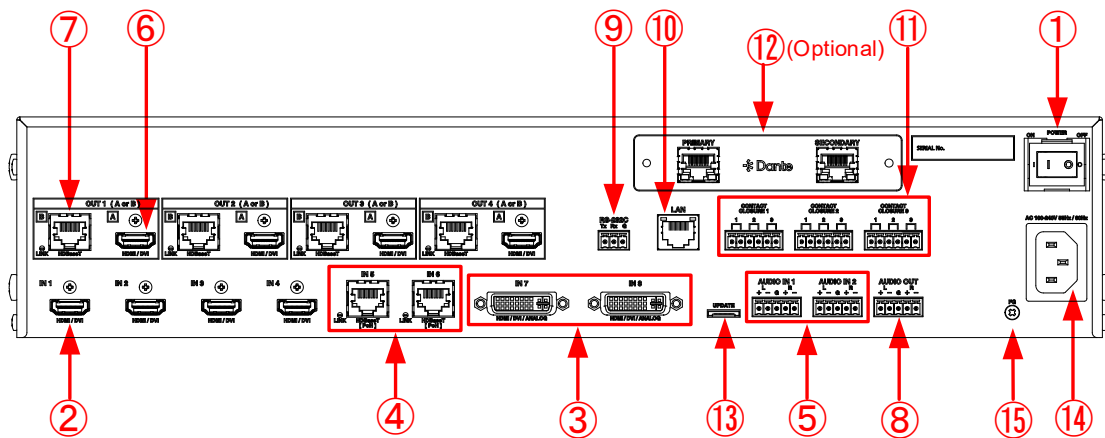

[Fig. 5.2] Rear panel drawing (MSD-6204 with Dante)

[Table 5.2] Rear panel features

#	Feature	Description
①	Main POWER switch	Controls the main power of the MSD. 【See: 8.1 Main power switch and standby key】
②	HDMI input connectors	Input connectors for HDMI and DVI signals to interface source devices, such as Blu-ray players.
③	DVI input connectors	Interfaces with DVI-I or DVI-D cable. The following video signals can be presented to these inputs: <ul style="list-style-type: none"> • DVI • HDMI • Analog RGB (such as PC) • Analog YPbPr (SDTV/HDTV) 【See: 7.2.2 DVI-I input connector】
④	HDBaseT input connectors	Input connector for HDBaseT signals Connects to a transmitter over a twisted pair cable. Provides power to HDBaseT transmitter that supports PoH. 【See: 7.2.3 Twisted pair cable for extension】 【See: 9.7.6 HDBaseT input long reach mode】
⑤	Audio input connectors	Input connectors (5-position terminal block) for analog audio signals 【See: 7.2.4 Connecting audio cable】

[Table 5.3] Rear panel features (Cont'd)

#	Feature	Description
⑥	HDMI output connectors	Output connectors for HDMI and DVI signal, interfaces with sink devices such as LC monitors and projectors. 【See: 9.9.8 Output connector】
⑦	HDBaseT output connectors	Output connector for HDBaseT signal Connects to a remote receiver over a twisted pair cable. 【See: 7.2.3 Twisted pair cable for extension】 【See: 9.9.8 Output connector】 【See: 9.9.17 HDBaseT output long reach mode】
⑧	Audio output connector	Analog audio output connectors interface to amplifiers, speakers, and mixers. Connector type is 5-position terminal block. 【See: 7.2.4 Connecting audio cable】
⑨	RS-232C connector	For external control by communication commands Connector type is 3-position terminal block. 【See: 7.2.5 Connecting RS-232C】
⑩	LAN connector	For external control by communication commands or web browsers
⑪	Contact closures	For external device control by dry contact closure Connector type is 6-position terminal block. 【See: 7.2.6 Contact closure】
⑫	Dante connectors (Optional)	Output connector for Dante audio Input digital and analog audio signals are converted into Dante format. 【See: 8.8 Dante output (Optional)】
⑬	Maintenance port	Factory use only
⑭	Power supply connector	For use with provided power cable.
⑮	Frame ground	Use for bonding chassis to local ground. An M3 screw is used.

<Video combination mode: Full HD Video>

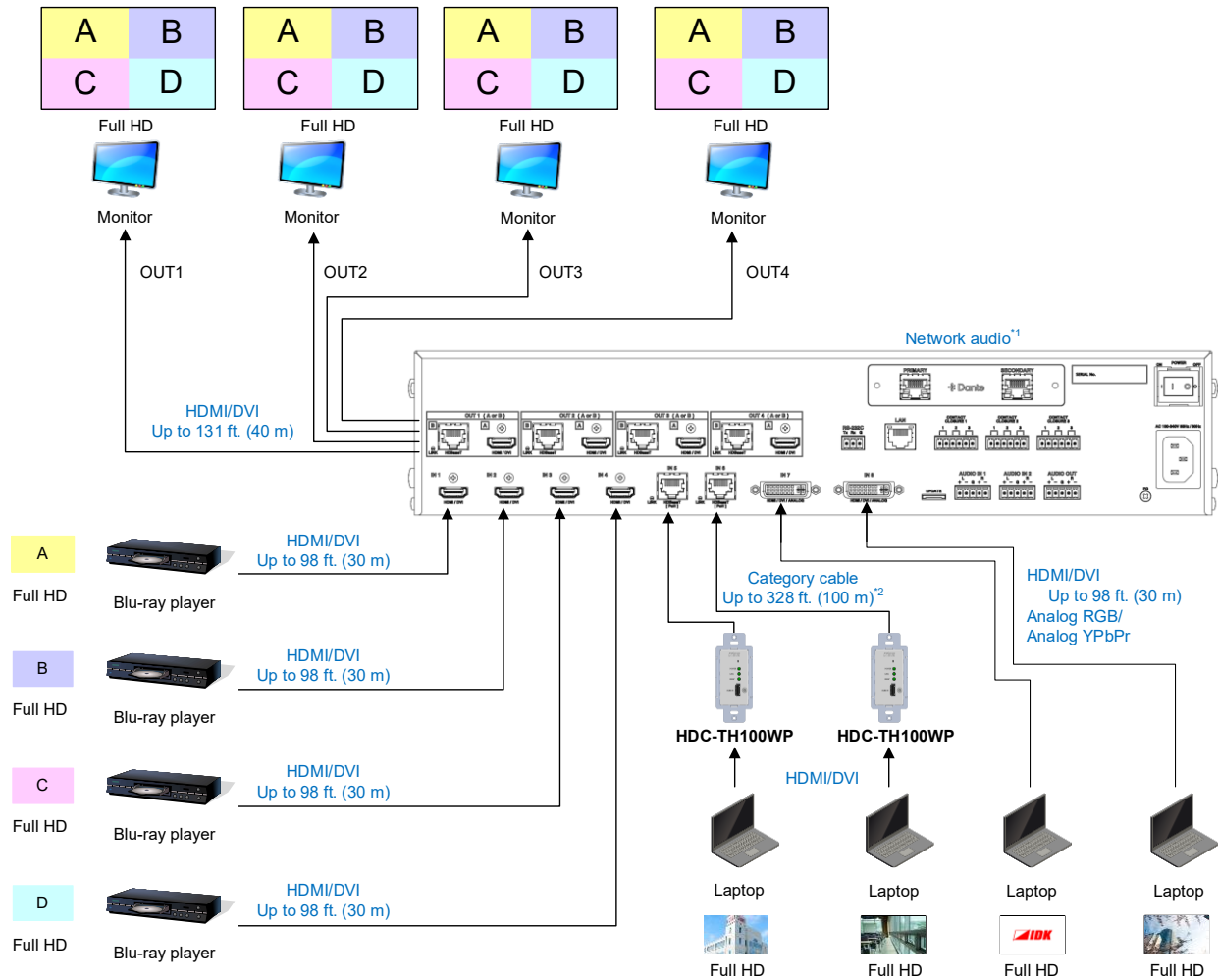

¹Dante output is optional.

²Transmission distances

Up to 328 ft. (100 m) : 4K@30

Up to 492 ft. (150 m) : 1080p (24 bit) in Long reach mode

For long reach mode, video signals up to 1080p (24 bit) can be transmitted to 492 ft. (150 m) at maximum if the MSD is used with IDK's HDBaseT transmitter or receiver that supports 328 ft. (100 m) extension.

[Fig. 6.2] Image combination mode (MSD-6204)

<4K mode: 4K Video>

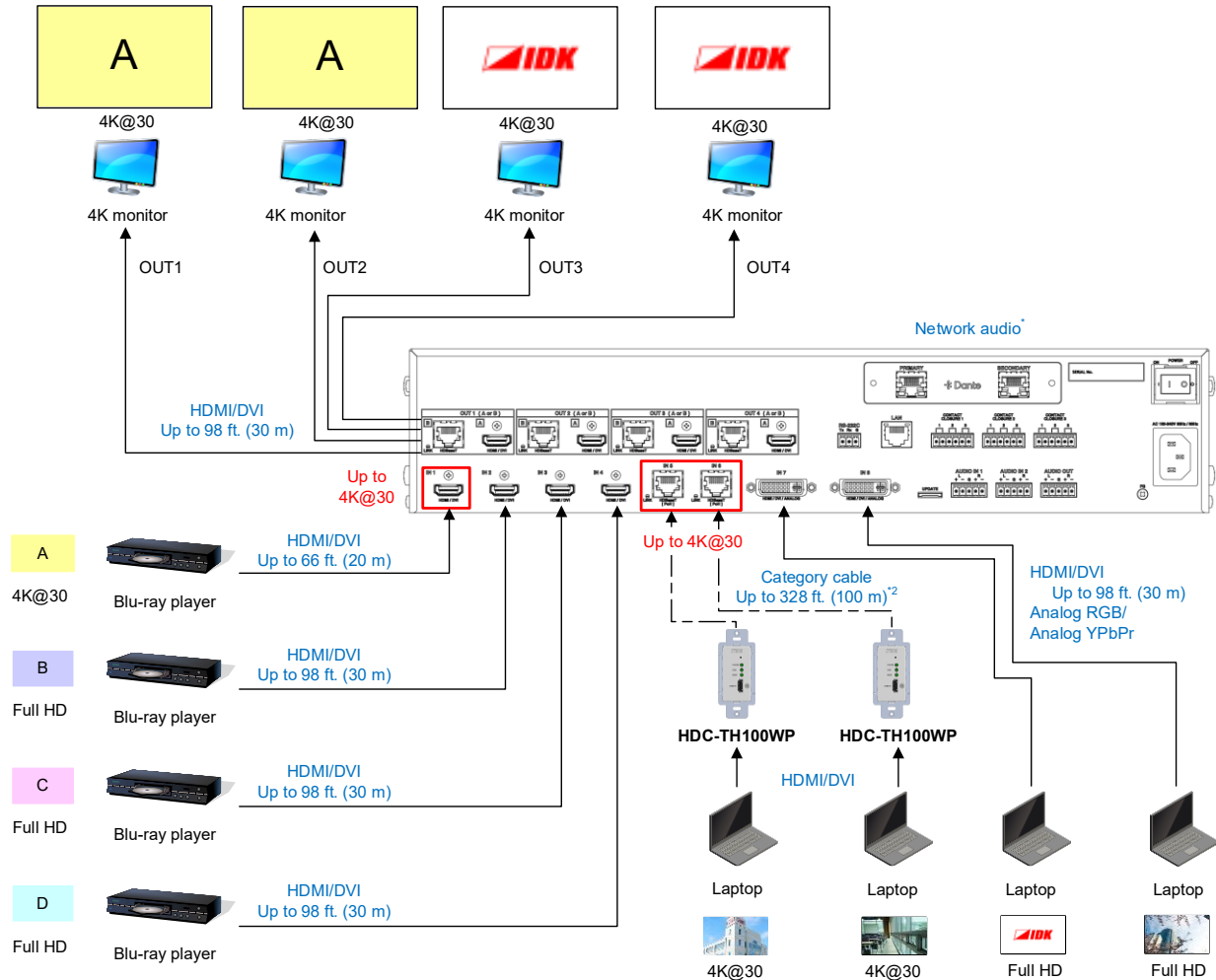

²Dante output is optional.

[Fig. 6.3] 4K mode (MSD-6204)

7 Precautions

Before connecting to external devices, follow the precautions below.

7.1 Installation

When installing the MSD, please observe the following precautions.

- Do not stack or place one MSD directly on top of another MSD.
- Do not block vent holes. To provide adequate ventilation, maintain sufficient clearances around the MSD (1.2 in. (30 mm) or more).
- When the MSD needs to be mounted in an EIA rack, or an enclosed space, ensure that sufficient ventilation or cooling is provided and that the ambient temperature will not exceed 104°F (40°C). If inadequately vented, the product's service life, operation and reliability may be affected.

■ Attaching rack mounting brackets

1. Remove four M5 screws from one side of the unit. Retain these screws for step 2.
2. Attach one bracket to the side of the unit using the screws removed in step 1.
3. Repeat steps 1 and 2 on the other side of the unit.

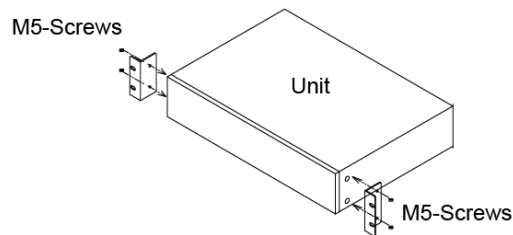

[Fig. 7.1] Attaching rack mounting brackets

Note:

The standard screw tightening torque is 2.94 N·m (about 30 kgf·cm).

7.2 Cabling

When connecting the MSD to external devices, please observe the following precautions.

- Read manuals for the external devices.
- Before connecting cables to the MSD or an external device, dissipate static electricity by touching grounded metal such as equipment racks before handling signal cables. Failure to observe this precaution may result in ESD (electrostatic discharge) damage.
- Power all units off before connecting cables.
- Be sure to fully seat all plugs and connections and dress cables to reduce stress on connectors.
- Use the cable lacing bracket to secure a standard HDMI cable as shown.

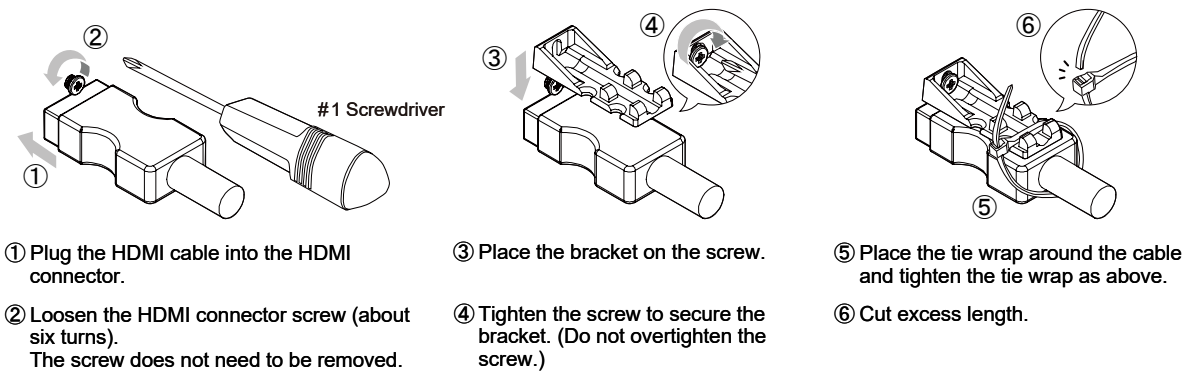

[Fig. 7.2] Cable Lacing Bracket (FB-01 For IDK products only)

7.2.1 Cables

Use the correct HDMI cable or HDMI-DVI conversion cable depending on the system configuration. For analog audio and RS-232C, select or fabricate cables to match the connectors as needed.

7.2.2 DVI-I input connector

Female 29-pin DVI-I connectors are used for DVI inputs.

The DVI-I input connectors can be used for HDMI/DVI digital signals and for analog signals.

■ DVI signal input

Use DVI-I or DVI-D cable.

Signal only supports single-link.

■ HDMI signal input

Use HDMI-DVI conversion cable.

■ Analog RGB signal input

Use conversion cable which has male DVI-I and female high-density D-sub (15-pin) conversion cable

■ Additional supported analog signal input types

Analog YPbPr/composite video/Y/C signals are supported.

Use conversion cables as needed for each signal.

Pin assignments for each signal type are shown below.

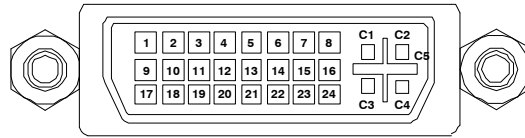

[Fig. 7.3] Female DVI-I (29-pin) connector

[Table 7.1] Pin assignments

Pin #	Input signal		
	HDMI / DVI	Analog RGB	Analog YPbPr
1	TMDS Data2-	N.C.	N.C.
2	TMDS Data2+	N.C.	N.C.
3	GND	N.C.	N.C.
4	N.C.	N.C.	N.C.
5	N.C.	N.C.	N.C.
6	DDC Clock	DDC Clock	N.C.
7	DDC Data	DDC Data	N.C.
8	N.C.	V-Sync	V-Sync
9	TMDS Data1-	N.C.	N.C.
10	TMDS Data1+	N.C.	N.C.
11	GND	N.C.	N.C.
12	N.C.	N.C.	N.C.
13	N.C.	N.C.	N.C.
14	+5V Power	N.C.	N.C.
15	GND	N.C.	N.C.
16	Hot Plug Detect	N.C.	N.C.
17	TMDS Data0-	N.C.	N.C.
18	TMDS Data0+	N.C.	N.C.
19	GND	N.C.	N.C.
20	N.C.	N.C.	N.C.
21	N.C.	N.C.	N.C.
22	GND	N.C.	N.C.
23	TMDS Clock+	N.C.	N.C.
24	TMDS Clock-	N.C.	N.C.
C1	N.C.	Red	Pr / Cr
C2	N.C.	Green/SOG	Y
C3	N.C.	Blue	Pb / Cb
C4	N.C.	H-Sync/CS	H-Sync
C5	N.C.	GND	GND

N.C. : Not Connection
 CS : Composite Sync

7.2.3 Twisted pair cable for extension

To ensure the best performance with twisted pair cables, select a high quality twisted pair cable type, ensuring that proper pinning and pairing requirements are observed.

- Cat5e UTP/STP and Cat6 UTP/STP can be used, but we recommend CAT.5E HDC cable* for optimal performance.
- If using STP cabling, connect the FG connector to a local electrical ground bonding point. Without bonding FG to ground, the shielding feature may not effectively eliminate interference. When using UTP cables, it is still recommend that the FG connector be used.
- The shielded STP cables are less affected by interference or external noise than UTP cables.
- Connectors for long-haul extension are the same as that of eight-core modular connector used for Ethernet, but the transmission system is not the same so that it cannot be connected to Ethernet.
- The maximum extension distance of a twisted pair cables is the shorter distance of the maximum extension distances of transmitter/receiver/sink device connected to the MSD.
- Pin assignments: T568A or T568B straight
- Do not pull the cable using excessive force. The allowable tension of the twisted pair cable is 110 N.
- Do not bend the cable at a sharp angle. Keep the bend radius four times of the cable diameter or larger.
- Do not clamp or tie the cable tightly; leave some space allowing the cable to move slightly.
- If you use multiple twisted pair cables, we recommended keeping a distance between the cables or not to place the cables closely in parallel.
- Keep the twisted pair cable running as straight as possible. Looping or coiling the cable, causes it to be more easily affected by noise; especially when using longer cable run lengths.
- Do not place the cable in an electrically noisy environment, since high-speed noise impulses may couple into the category cable. Use of a high-output radio transmission device near the MSD or remote receivers may interfere with or interrupt video and or audio signals.
- If the total extension distance from the transmitter to receiver is 328 ft. (100 m) or less, up to two cable interconnection points can be used. Products supporting Cat6A (10GBase-T) are recommended. The maximum extension distance of high-resolution transmission, such as 4K, may be shortened by about 10% compared with other lower bandwidth resolution formats.
- Use AWG 24 or heavier gauge cable for PoH applications.
- The table below shows supported extension distance for each twisted pair cable category. Note that specified distances may shorten depending upon the conditions within the actual environment.

[Table 7.2] Extension distance

Noise influence	Category		Extension distance	TMDS clock	Recommended cable
Easily affected	UTP	Cat5e	164 ft. (50 m)	\leq 225 MHz	For 164 ft. (50 m) or longer: CAT.5E HDC*, Cat5e STP, and Cat6 UTP/STP cables
		Cat6	328 ft. (100 m)		
Less affected	STP		Cat5e*	230 ft. (70 m)	> 225 MHz (4K format)
		Cat6		328 ft. (100 m)	
		Cat6	492 ft. (150 m)	Long reach mode \leq 148 MHz (1080p (24 bit) or less)	CAT.5E HDC, Cat5e STP, and Cat6 STP cables

* The CAT.5E HDC cable is a double-shielded twisted pair cable optimized for video signal transmission. It is certified to 500 MHz bandwidth at distances up to 328 ft. (100 m) and verified to meet requirements specified by HDBaseT Alliance. The double-shielded structure protects the video signal from external interference.

Note:

If there is a problem in the transmission path, video or audio may be interrupted. Check the precautions above. If the problem persists, it may be necessary to shorten the twisted pair cable.

7.2.4 Connecting audio cable

The MSD's audio input and output connectors mate with 5-position terminal blocks.

Connect audio cables to the 5-position terminal blocks. The MSD supports both balanced and unbalanced analog signals.

AWG24 to AWG16 conductor gauge and a strip length of 0.28 in. (7 mm) are recommended.

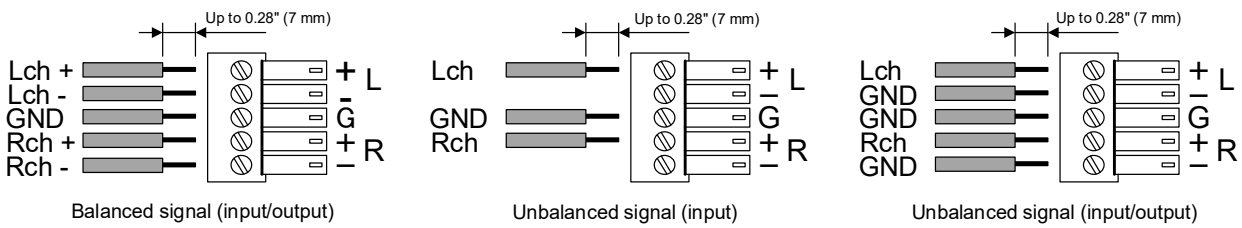

[Fig. 7.4] Connecting audio cable to 5-position terminal block connector

7.2.5 Connecting RS-232C cable

The MSD's RS-232C connection is supported by a 3-position terminal block.

Insert and secure the wires from the RS-232C cable into the supplied 3-position terminal block, and then insert the terminal block into the mating connector on the MSD.

AWG24 to AWG16 conductor gauge is recommended. The recommended wire strip length is 0.28 in. (7 mm). Short RTS/CTS and DTR/DSR as needed.

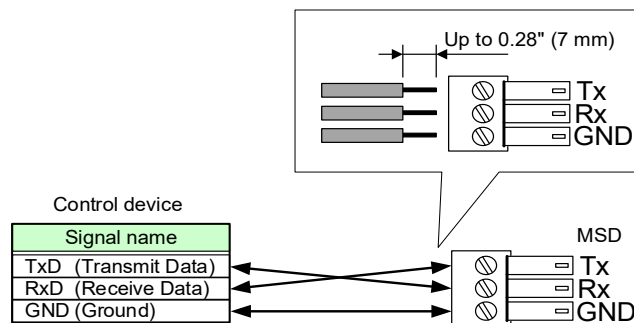

[Fig. 7.5] Connecting RS-232C cable into 3-position terminal block

7.2.6 Contact closure

The MSD has a total of nine (9) independently controlled contact closure channels for external control. Each connector supports three (3) channels. The maximum load is 500 mA at 24 VDC per contact.

Connect a cable to the 6-position terminal block, and then insert into the appropriate connector on the MSD's rear panel.

AWG24 to AWG16 conductor gauge is recommended. The recommended wire strip length is 0.28 in. (7 mm).

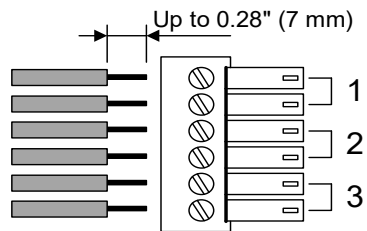

[Fig. 7.6] Connecting cable to 6-position terminal block connector

8 Basic Operation

8.1 Main power switch and standby key

The rear panel has the main power switch while the front panel includes the standby key.

The power LED on the front panel shows the device's power status.

[Table 8.1] Power status

Status	LED	Main power switch	Standby key
Power off	Does not illuminate	OFF	---
Standby	Illuminates (orange)	ON	OFF (Does not illuminate)
Power on	Illuminates (green)	ON	ON (Illuminate, green)

The MSD power can be controlled by the standby key, RS-232C or LAN during standby state.

Start-up power status can be set in "**9.17.1 Power state**".

[See: 9.17.1 Power state]

8.1.1 Power up period

After powering on the MSD from a power-off condition, there is a short initialization delay before the WEB browser is fully operational and before the first communication command can be received and executed.

Predictable behavior during power up can be maintained by observing the recommended delay periods listed below.

[Table 8.2] Power up period

Operation	Period
Receiving communication command	6 seconds
Receiving front panel operation	12 seconds or longer

Note:

If "**9.16.7 Startup bitmap output**" is set to "ON", the required period for the front panel operation may be longer.

8.2 Selecting input channels

You can select desired input channels for video and audio signals by pressing the input channel selection key for each output channel.

Input video and audio signals can be switched simultaneously. Audio can be selected separately via settings in “9.3.1 Channel switching mode”. The selected channel switching mode (V&A/VIDEO/AUDIO) can be checked in the VFD screen.

“V&A” or “VIDEO”: Input channels that are selected for video signals illuminate.

“AUDIO” : Input channels that are selected for audio signals illuminate.

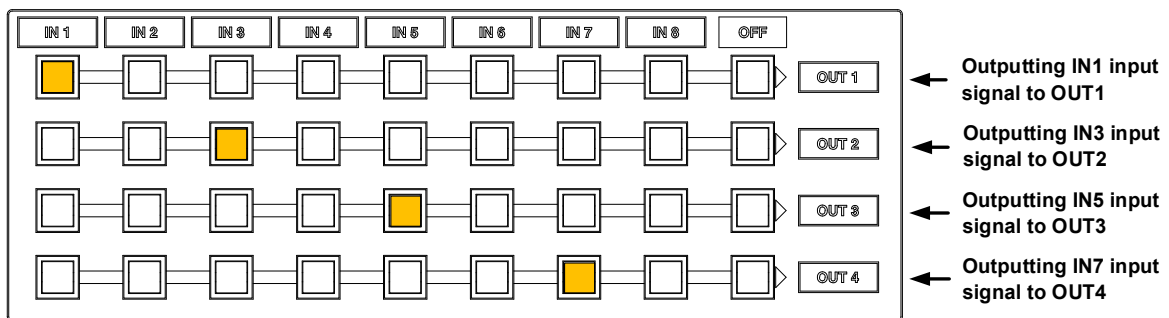

[Fig. 8.1] Crosspoint indication (MSD-6204)

8.3 Video processing mode

The MSD has three video processing modes: Normal mode, video combination mode (overlay), and 4K mode.

You can select a mode in “9.5.1 Video output mode”.

Input channels can be switched from the front panel, menu, WEB browser, or communication commands.

Note:

Only one video processing mode can be used at a time.

8.3.1 Normal mode

Video signals with dot clock frequencies up to 165 MHz can be input or output. This mode is set by default.

【See: 6 System Configuration Example】

8.3.2 Video combination mode

Video signals with dot clock frequencies up to 165 MHz can be input or output.

For MSD-6203 and MSD-6204 in video combination mode, the same video is provided at each output channel.

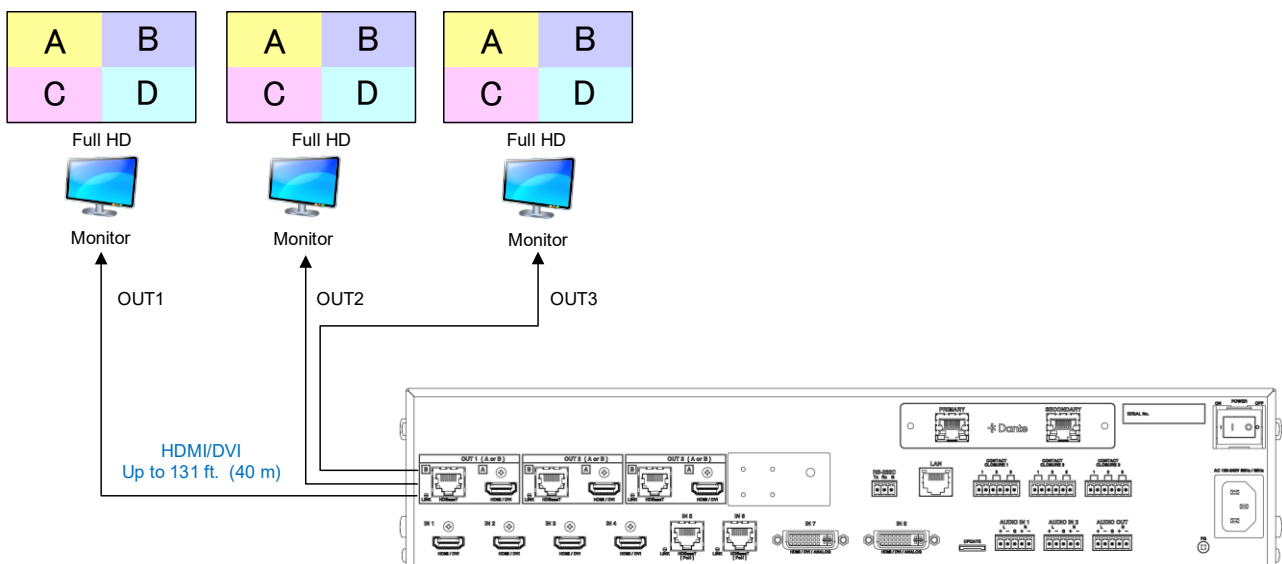

[Fig. 8.2] Video combination mode (MSD-6203 with Dante)

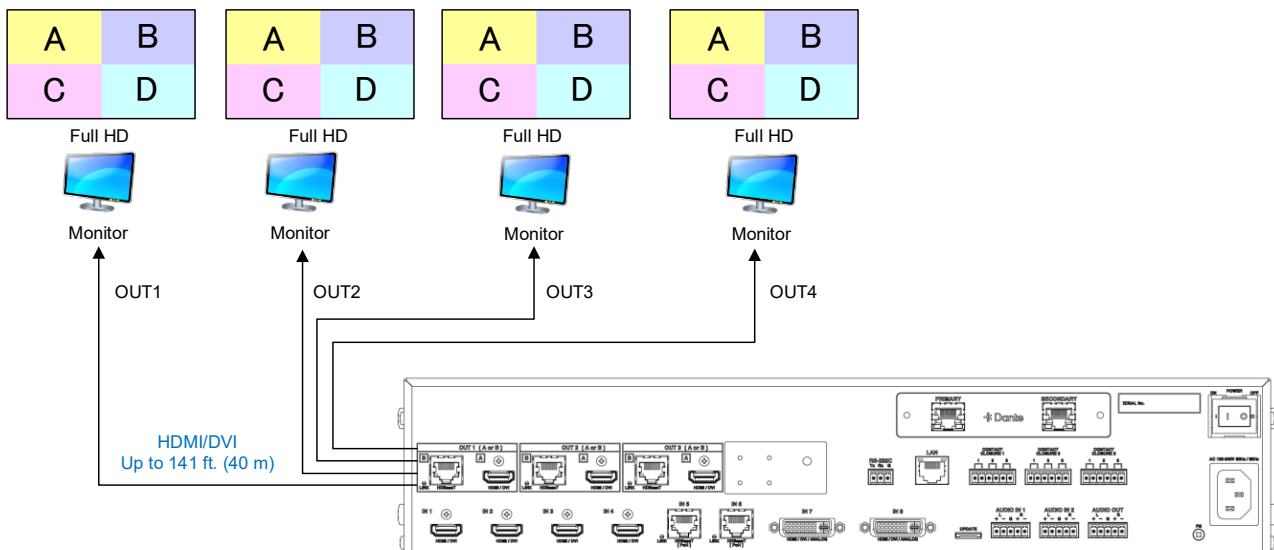

[Fig. 8.3] Video combination mode (MSD-6204 with Dante)

■ Window settings for MSD-6203:

For MSD-6203, you can switch input channel of Window4 from the menu, a WEB browser, or communication commands.

【See: 9.5.2 Window setting】

■ Changing window display position and size:

You can change the window display position and size from output display position and output display size in “9.4.6 Display position” and “9.4.7 Display size”, respectively.

【See: 9.4.6 Display position】

【See: 9.4.7 Display size】

■ Window display priority

When multiple windows are overlaid with overlapping areas, the window with higher priority will have its full area displayed.

【See: 9.5.3 Window layer order】

■ Hiding window

You can set all windows to be displayed or not displayed separately.

If changing the number of windows, set “9.5.5 Window hiding” to “INVISIBLE”.

【See: 9.5.5 Window hiding】

■ **Video combination stored in preset memory**

Three video combinations are stored in the preset memories No.10 to No.12 as combination examples.

【See: 9.15.4 Recalling all settings】

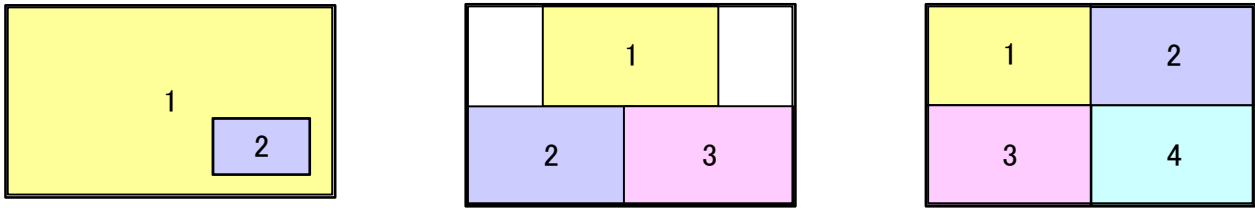

[Fig. 8.4] Video combination in preset memory

8.3.3 4K mode

Video signals with dot clock frequencies exceeding 165 MHz can be input or output.

4K@30 video signals can be input from IN1, IN5, or IN6. Video signals that are input from other channels can be converted to 4K@30.

Video and audio of the selected input channel are output to output channels as follows.

[Table 8.3] Same signal is output to the following groups

Model	Group
MSD-6203	Group1: OUT1 and OUT2 Group2: OUT3
MSD-6204	Group1: OUT1 and OUT2 Group2: OUT3 and OUT4

Note:

For sink devices to be connected to an output group, the supported resolution needs to be the same.

■ **Selecting input channel (for MSD-6203 and MSD-6204)**

MSD-6203 and MSD-6204: Set output channels to OUT1 or OUT3 first, and then select the input channel.

For other output channels, LEDs of input channel selection keys cannot be selected and do not illuminate.

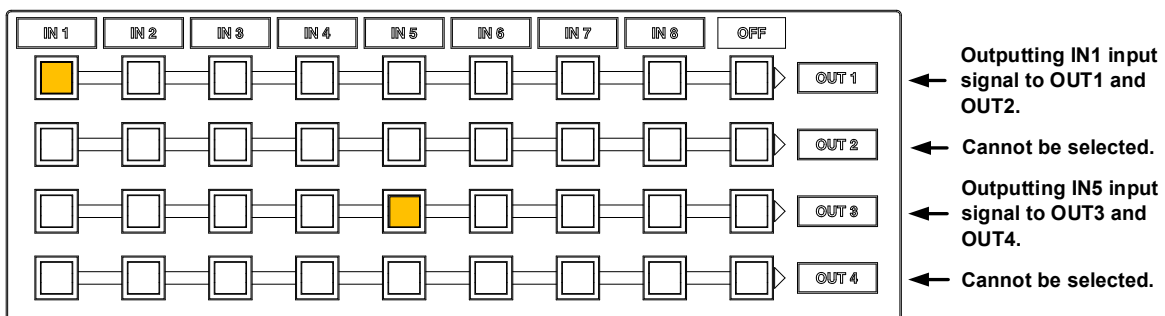

[Fig. 8.5] Front panel with 4K mode (MSD-6204)

Note:

For even-numbered output channels, the settable menus and WEB browser will be displayed. Only settable communication commands can be sent.

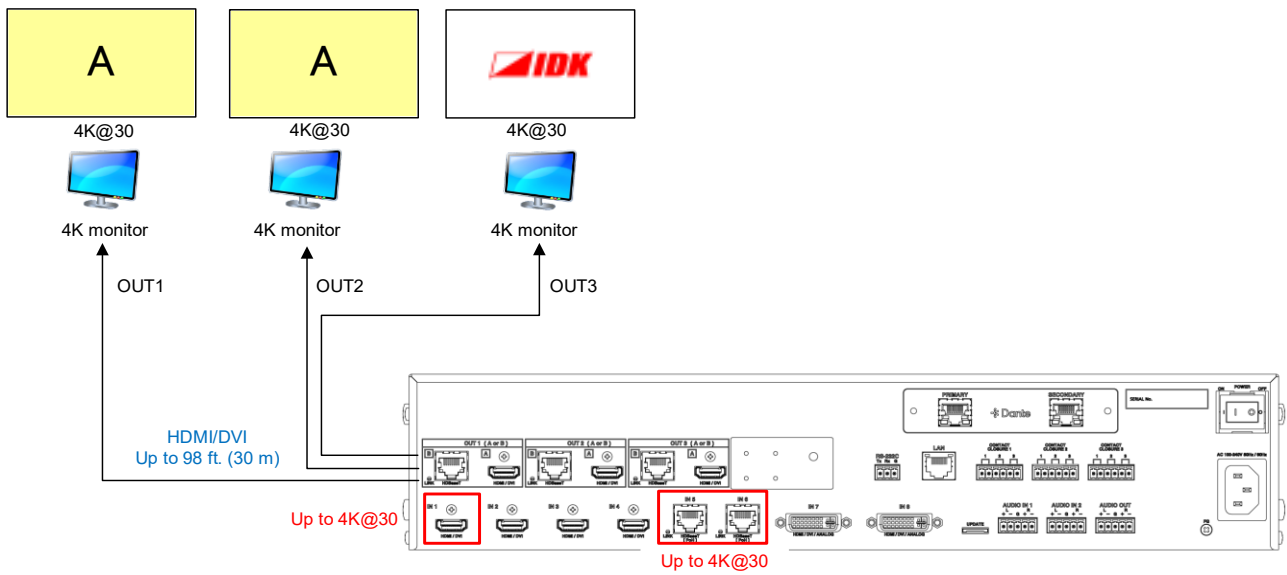

[Fig. 8.6] Video output with 4K mode (MSD-6203 with Dante)

Tip:

4K@30 video is output from OUT3 (MSD-6203).

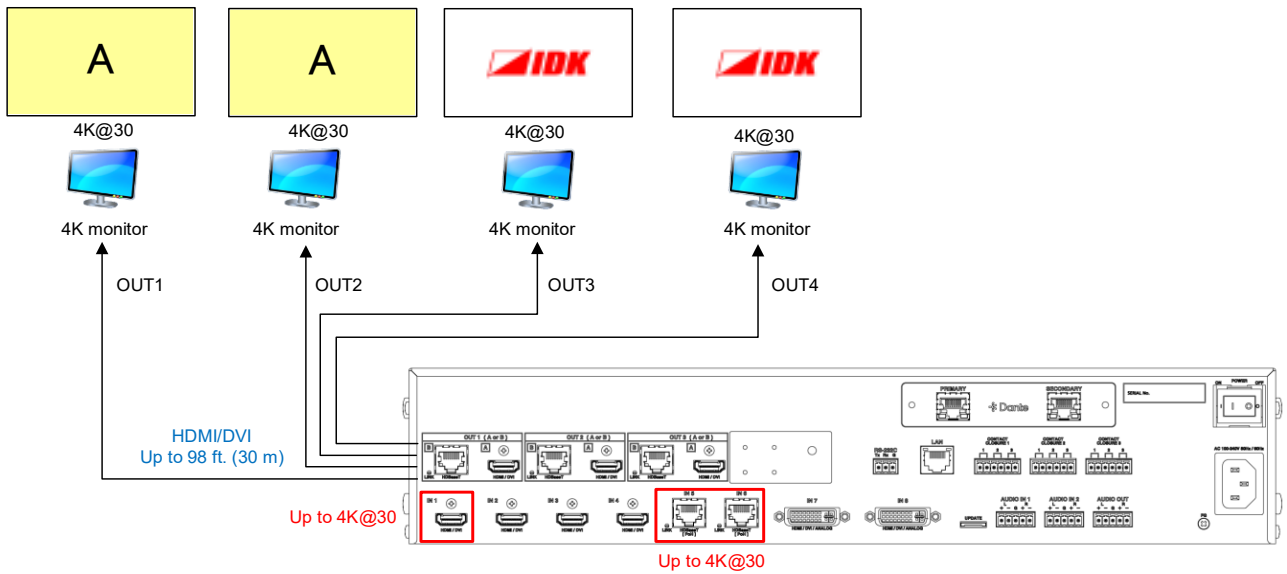

[Fig. 8.7] Video output with 4K mode (MSD-6204 with Dante)

8.4 Menu operation

You can use the VFD screen and front panel keys to view and control settings.

Press the “MENU/SET” key to apply settings and to change the menu level.

Press the “ESC” key to go back to the previous screen.

Use the “▲” and “▼” keys to select channels and use the “▲” and “▼” keys to select menu items.

In the setting screen, use “▲”, “▼”, “▲” and “▼” keys to move the cursor and select the desired setting.

The applied values are saved automatically after exiting the session.

【See: 9.1 Menu list】

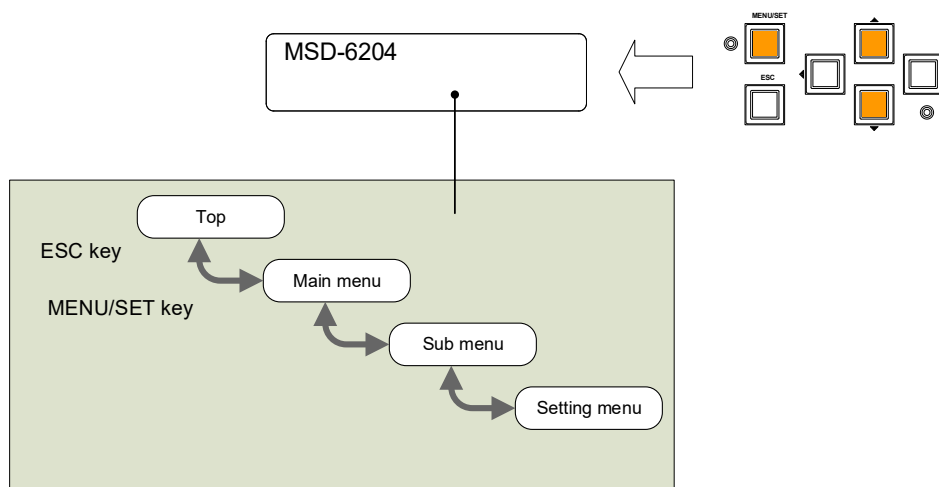

【Fig. 8.8】 Menu level

Tips:

- The “MENU/SET” key LED is illuminated only for menus with user settings.
- For some setting screens, the setting value is applied by pressing the “MENU/SET” key. When the “MENU/SET” key flashes, press the key to apply the setting value. After the setting has been applied, the key will illuminate without flashing.
- We offer an optional cover for menu operation keys to prevent accidental key presses. Please contact us as needed.

Note:

To avoid losing settings, do not interrupt power to the MSD while “NOW SAVING” is displayed; otherwise, the setting information may be lost.

8.5 Sink device power control

You can register control commands to power connected sink devices on/off. By pressing the appropriate key, control commands are sent to the sink device.

The DISPLAY POWER key illuminates when the sink device is powered on. The key does not illuminate when the sink device is powered off.

The DISPLAY POWER key illuminates based on the sink device power status when reply command is sent from the sink device.

【See: 9.14.3 Command link】

Note:

If the reply command from the sink device is not considered, the actual power status of the sink device and the LED may not match.

【See: 9.14.1 Registering/editing control command】

8.6 Command control

You can run commands that are linked to each control command execution key (COMMAND A to COMMAND E).

No command is registered by default. Register commands and link them to control command execution keys.

【See: 9.14.3 Command link】

8.7 Locking and unlocking key function

Press and hold the “ESC” key for two seconds or longer to set/cancel keylock for keys below. You will hear a beep tone and then one of the following messages is displayed for one second.

You can group target keys.

- OPERATION LOCK ! (Locked)
- OP LOCK RELEASE ! (Unlocked)

【See: 9.18.1 Grouping key function lock】

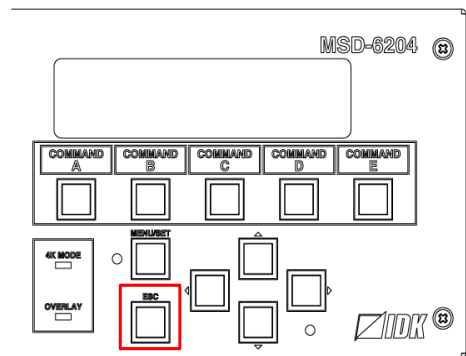

Press and hold for
2 seconds or longer

[Fig. 8.9] Keys can be locked/unlocked (MSD-6204)

8.8 Dante output (Optional)

Dante (Digital Audio Network Through Ethernet) is an audio networking technology developed by Audinate. The MSD converts digital and analog audio into Dante format with 48-kHz sampling frequency and 24-bit sample size.

Up to 64 channels can be output. Multi-channel PCM output is assigned to Dante output channel. However, Dante output channels 61 to 64 channels can be selected from digital audio input or analog audio input.

【See: 9.19.1 CH61-CH64】

[Table 8.4] Dante output channel and audio input channel

Dante output channel	Audio input channel	Dante output channel	Audio input channel
CH1	IN1-CH1	CH33	IN5-CH1
CH2	IN1-CH2	CH34	IN5-CH2
CH3	IN1-CH3	CH35	IN5-CH3
CH4	IN1-CH4	CH36	IN5-CH4
CH5	IN1-CH5	CH37	IN5-CH5
CH6	IN1-CH6	CH38	IN5-CH6
CH7	IN1-CH7	CH39	IN5-CH7
CH8	IN1-CH8	CH40	IN5-CH8
CH9	IN2-CH1	CH41	IN6-CH1
CH10	IN2-CH2	CH42	IN6-CH2
CH11	IN2-CH3	CH43	IN6-CH3
CH12	IN2-CH4	CH44	IN6-CH4
CH13	IN2-CH5	CH45	IN6-CH5
CH14	IN2-CH6	CH46	IN6-CH6
CH15	IN2-CH7	CH47	IN6-CH7
CH16	IN2-CH8	CH48	IN6-CH8
CH17	IN3-CH1	CH49	IN7-CH1
CH18	IN3-CH2	CH50	IN7-CH2
CH19	IN3-CH3	CH51	IN7-CH3
CH20	IN3-CH4	CH52	IN7-CH4
CH21	IN3-CH5	CH53	IN7-CH5
CH22	IN3-CH6	CH54	IN7-CH6
CH23	IN3-CH7	CH55	IN7-CH7
CH24	IN3-CH8	CH56	IN7-CH8
CH25	IN4-CH1	CH57	IN8-CH1
CH26	IN4-CH2	CH58	IN8-CH2
CH27	IN4-CH3	CH59	IN8-CH3
CH28	IN4-CH4	CH60	IN8-CH4
CH29	IN4-CH5	CH61	IN8-CH5/AUDIO IN1-L
CH30	IN4-CH6	CH62	IN8-CH6/AUDIO IN1-R
CH31	IN4-CH7	CH63	IN8-CH7/AUDIO IN2-L
CH32	IN4-CH8	CH64	IN8-CH8/AUDIO IN2-R

Note:

Compressed audio is not output as Dante audio and the audio will be muted.

8.8.1 IP network connection

Redundant connection and Daisy chain connection (Redundant connection is set by default) are supported for devices with Dante.

The IP address for Dante connectors (Primary and Secondary) is automatically obtained over IP network. Use a Cat5e or better cable for Dante.

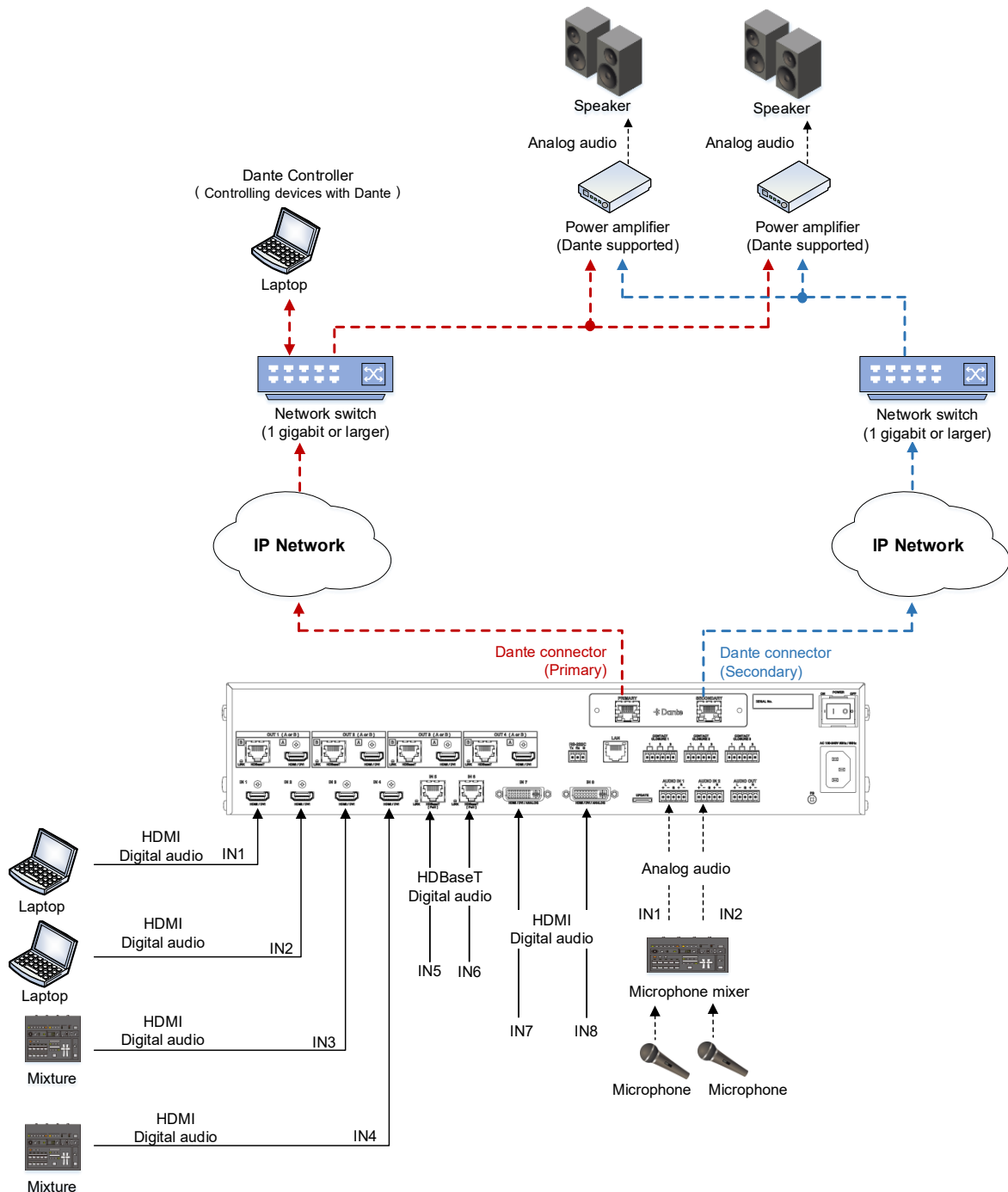

[Fig. 8.10] Redundant connection

Note:

For redundant operation, do not connect the Dante primary and secondary connectors to the same IP network.

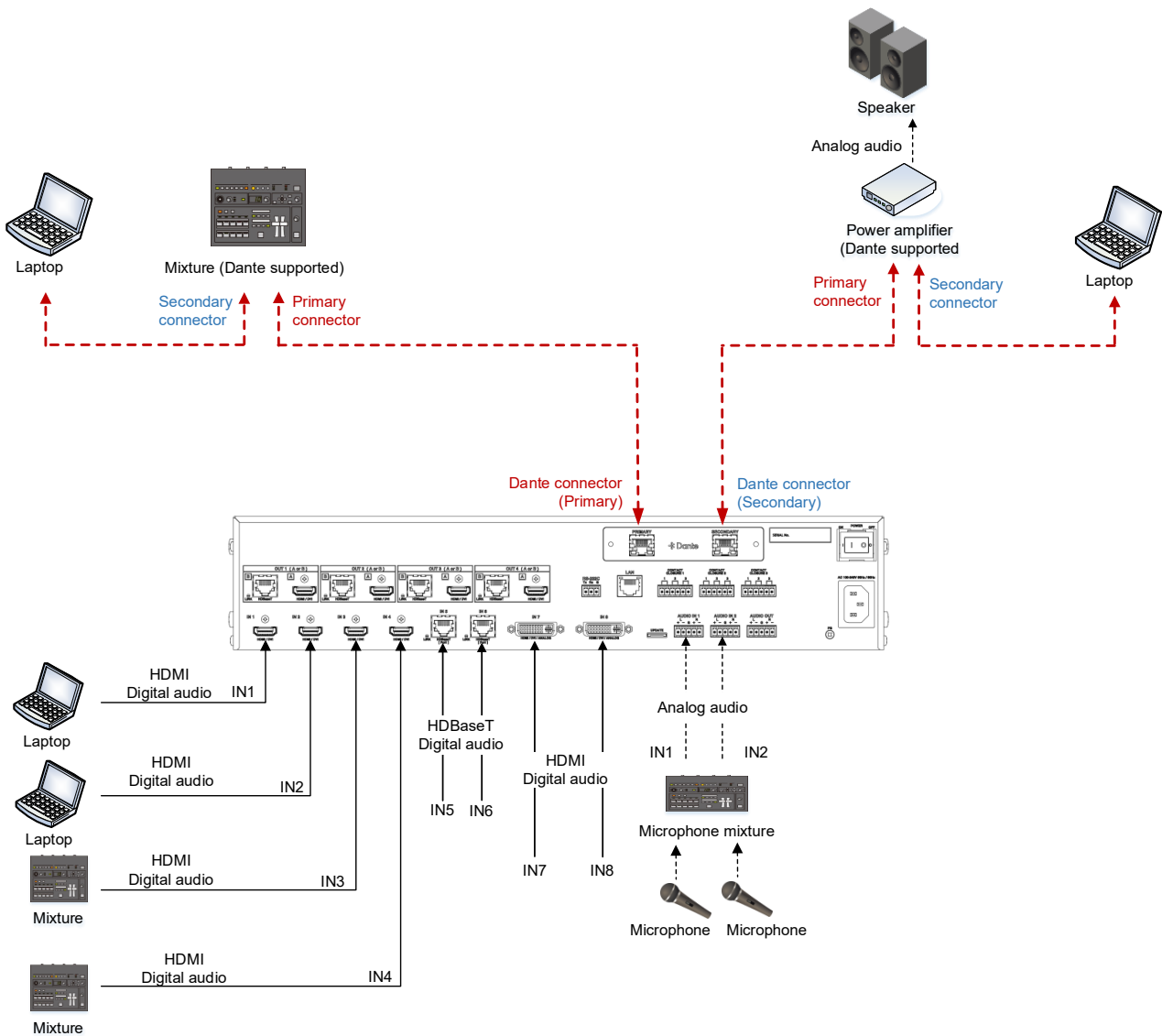

[Fig. 8.11] Daisy chain connection

8.8.2 Dante Controller

Use Dante Controller released by Audinate for setting Dante output functions and for setting audio routing with Dante-supported devices. These settings are saved in Dante-supported devices.

For “Dante Controller” details and to download the software, visit the website below:
<https://www.audinate.com/>

8.9 Initialization

All user configurable settings can be reset to their respective factory default values by powering the MSD on while simultaneously depressing the “ESC” key.

Press and hold the “ESC” key until you hear a long beep tone.

The following tables show factory defaults.

When settings are initialized from the WEB browser, they can be initialized without changing LAN settings.

Note that after returning to factory default, the previous setting values cannot be restored. Some menus can be set for each input channel and output channel individually; see “[Table 8.17] Setting condition” for details.

[Table 8.5] Factory default

Menu	Factory default		See
FRONT OPERATION			
SWITCHING MODE	For	---	P.62
	Default	V&A	
COMMAND/PRESET	For	---	P.62
	Default	LOCK	

[Table 8.6] Factory default (Cont'd)

Menu	Factory default		See
OUTPUT TIMING			
RESOLUTION	For	Each output channel	P.63
	Default	AUTO	
MONITOR ASPECT	For	Each output channel	P.64
	Default	RESOLUTION	
INPUT ASPECT	For	Each input channel, each input signal	P.64
	Default	AUTO-1	
ASPECT PROCESS	For	Each input channel, each input signal	P.65
	Default	L-BOX/S-PANEL	
INPUT OVER SCAN	For	Each input channel, each input signal	P.65
	Default	105% [SDTV input] 100% [HDTV/PC input]	
INPUT POSITION	For	Each input channel, each input signal	P.65
	Default	H: 0, V: 0	
INPUT SIZE	For	Each input channel, each input signal	P.66
	Default	H: Horizontal output resolution V: Vertical output resolution	
INPUT MASKING	For	Each input channel, each input signal	P.67
	Default	L : 0 R: Horizontal input size T : 0 B: Vertical input size	
INPUT AUTO SIZING	For	Each input channel, each input signal	P.67
	Default	---	
OUTPUT POSITION	For	Each output channel	P.65
	Default	H: 0, V: 0	
OUTPUT SIZE	For	Each output channel	P.66
	Default	H: Horizontal output resolution V: Vertical output resolution	
OUTPUT MASKING	For	Each output channel	P.67
	Default	L : 0 R: Horizontal output resolution T : 0 B: Vertical output resolution	
OUTPUT AUTO SIZING	For	Each output channel	P.67
	Default	---	
BACKGROUND COLOR	For	Each output channel	P.68
	Default	R: 0, G: 0, B: 0	
TEST PATTERN	For	Each output channel	P.68
	Default	OFF	

[Table 8.7] Factory default (Cont'd)

Menu	Factory default		See
VIDEO FUNCTION			
MODE SELECT	For	---	P.69
	Default	OFF	
WINDOW INPUT CH	For	Each window	P.69
	Default	OFF	
WINDOW PRIORITY	For	Each window	P.70
	Default	WINDOW1: Priority 1 (high) WINDOW2: Priority 2 WINDOW3: Priority 3 WINDOW4: Priority 4 (low)	
WINDOW FLIP H	For	Each window	P.71
	Default	OFF	
WINDOW INVISIBLE	For	Each window	P.71
	Default	VISIBLE	
IMAGE EFFECT			
INPUT SHARPNESS	For	Each input channel, each input signal	P.72
	Default	0	
INPUT BRIGHTNESS	For	Each input channel, each input signal	P.72
	Default	100%	
INPUT CONTRAST	For	Each input channel, each input signal	P.72
	Default	R : 100% G : 100% B : 100%	
INPUT HUE	For	Each input channel, each input signal	P.73
	Default	0 °	
INPUT SATURATION	For	Each input channel, each input signal	P.73
	Default	100%	
INPUT SETUP LEVEL	For	Each input channel, each input signal	P.73
	Default	0.0%	
IN DEFAULT COLOR	For	Each input channel, each input signal	P.74
	Default	---	
OUTPUT BRIGHTNESS	For	Each output channel	P.72
	Default	100%	
OUTPUT CONTRAST	For	Each output channel	P.72
	Default	R : 100% G : 100% B : 100%	
OUTPUT GAMMA	For	Each output channel	P.73
	Default	1.0	
OUT DEFAULT COLOR	For	Each output channel	P.74
	Default	---	

[Table 8.8] Factory default (Cont'd)

Menu	Factory default		See
INPUT SETTING			
INPUT VIDEO DETECT	For	Each input channel, digital input only	P.75
	Default	10000 ms	
HDCP INPUT ENABLE	For	Each input channel, digital input only	P.76
	Default	HDCP 1.4	
ANALOG INPUT TYPE	For	Each input channel, each input signal, analog input only	P.77
	Default	AUTO	
INPUT OFF CHECK	For	Each input channel	P.78
	Default	ON	
INPUT AD TYPE	For	Each input channel, DVI connector only	P.78
	Default	DIGITAL	
LONG REACH MODE	For	Each HDBaseT input channel	P.78
	Default	OFF	
INPUT TABLE FIXED	For	Each input channel	P.79
	Default	[Setting mode] SELECTED [Individual setting (if "SELECTED" is selected for the setting mode)] ASPECT : OFF, ANALOG TYPE : ON(FIXED), AUDIO LEVEL : ON(FIXED)	

[Table 8.9] Factory default (Cont'd)

Menu	Factory default		See
INPUT TIMING			
AUTO SETUP	For	Each input channel, each input signal, analog input only* ¹	P.81
	Default	NORMAL MODE	
H TOTAL DOTS	For	Each input channel, each input signal, analog input only* ¹	P.83
	Default	Depends on input signal	
H START	For	Each input channel, each input signal	P.83
	Default	Depends on input signal	
H DISPLAY	For	Each input channel, each input signal	P.84
	Default	Depends on input signal	
V START	For	Each input channel, each input signal	P.83
	Default	Depends on input signal	
V DISPLAY	For	Each input channel, each input signal	P.84
	Default	Depends on input signal	
AUTO START POS	For	Each input channel, each input signal, analog input only* ¹	P.85
	Default	ON	
UNKNOWN TIMING	For	---	P.85
	Default	AUTO SETUP ON	
LOAD	For	Each input channel, each input signal	P.86
	Default	---	
SAVE	For	Each input channel, each input signal, analog input only* ¹	P.86
	Default	---	
TRACKING	For	Each input channel, each input signal, analog input only* ¹	P.86
	Default	0	

*¹ Can be set and executed only if an analog RGB or YPbPr signal input is active.

[Table 8.10] Factory default (Cont'd)

Menu	Factory default		See
OUTPUT SETTING			
OUTPUT EQUALIZER	For	Each output channel	P.87
	Default	OFF	
OUTPUT MODE	For	Each output channel	P.87
	Default	HDMI YCbCr 4:4:4 MODE	
SYNC OUTPUT	For	Each output channel	P.88
	Default	ON	
VIDEO OUTPUT	For	Each output channel	P.88
	Default	BLUE	
VIDEO SWITCHING	For	Each output channel	P.89
	Default	FREEZE→FADE OUT-IN	
SWITCHING SPEED	For	Each output channel	P.89
	Default	350 ms	
WIPE COLOR	For	Each output channel	P.89
	Default	R: 0, G: 0, B: 0	
OUTPUT CONNECTOR	For	Each output channel	P.90
	Default	HDMI	
HDCP OUTPUT MODE	For	Each output channel	P.90
	Default	ALWAYS	
HDCP ERROR RETRY	For	Each output channel	P.91
	Default	ETERNITY	
DEEP COLOR OUTPUT	For	Each output channel	P.91
	Default	24-BIT COLOR	
CEC CONNECTION	For	Each output channel	P.92
	Default	NOT CONNECTED	
HDCP AUTHORIZATION	For	Each output channel	P.92
	Default	---	
AUTO SWITCHING ON	For	Each output channel	P.93
	Default	OFF	
AUTO SWITCHING OFF	For	Each output channel	P.93
	Default	OFF	
AUTO SWITCHING MASK	For	Each output channel	P.95
	Default	0s000ms	
AUTO SWITCHING MODE	For	Each output channel	P.95
	Default	V&A	
LONG REACH MODE	For	Each HDBaseT output channel	P.95
	Default	OFF	

[Table 8.11] Factory default (Cont'd)

Menu	Factory default		See
AUDIO			
OUTPUT LEVEL	For	Each output channel	P.97
	Default	0 dB	
OUTPUT MUTE	For	Each output channel	P.97
	Default	OFF	
AUDIO INPUT SELECT	For	Each input channel	P.97
	Default	DIGITAL	
INPUT OFFSET	For	Each input channel, each input signal	P.97
	Default	0 dB	
OUTPUT LIP SYNC	For	Each output channel	P.98
	Default	0 FRAME	
INPUT LIP SYNC	For	Each input channel, each input signal	P.98
	Default	0 FRAME	
SAMPLING FREQUENCY	For	Each output channel	P.98
	Default	AUTO	
ANALOG OUTPUT	For	Audio output connector	P.99
	Default	OUT1	
MULTI AUDIO	For	Each output channel	P.99
	Default	DOWN MIX	
TEST TONE	For	Each output channel	P.100
	Default	TEST TONE : OFF SPEAKER : ALL	

[Table 8.12] Factory default (Cont'd)

Menu	Factory default		See
EDID			
EDID DATA	For	Each input channel, digital input only	P.101
	Default	INTERNAL EDID	
PC RESOLUTION	For	Each input channel	P.102
	Default	1080p (1920x1080)	
AV RESOLUTION	For	Each input channel, digital input only* ²	P.104
	Default	AUTO	
DEEP COLOR INPUT	For	Each input channel, digital input only* ²	P.105
	Default	24-BIT COLOR	
AUDIO FORMAT	For	Each input channel, digital input only* ²	P.105
	Default	PCM : 48 kHz Dolby Digital : OFF AAC : OFF Dolby Digital+ : OFF DTS : OFF DTS-HD : OFF Dolby TrueHD : OFF	
SPEAKER	For	Each input channel, digital input only* ²	P.106
	Default	MODE : AUTO NUMBER : 2 FL/FR : ON LFE : OFF FC : OFF RL/RR : OFF RC : OFF FLC/FRC : OFF RLC/RRC : OFF FLW/FRW : OFF FLH/RLH : OFF TC : OFF FCH : OFF	
MONITOR EDID COPY	For	No.1 to No.8	P.107
	Default	---	

*² Can be set only if "INTERNAL EDID" is selected as the EDID mode.

[Table 8.13] Factory default (Cont'd)

Menu	Factory default		See
COM PORT			
PARAMETERS	For	RS-232C channel	P.108
	Default	Baud rate : 9600 Data bit length: 8 Parity check : NONE Stop bit : 1	
FUNCTION	For	RS-232C channel	P.108
	Default	RECEIVER ("RECEIVER" mode)	
FORWARDING	For	RS-232C channel	P.109
	Default	OFF	
FWD TX CH	For	Each HDBaseT output channel, each HDBaseT input channel	P.109
	Default	OFF	
FWD RX CH	For	---	P.109
	Default	OUT1B	
LAN			
IP ADDRESS	For	---	P.111
	Default	192.168.1.199	
SUBNET MASK	For	---	P.111
	Default	255.255.255.0	
GATEWAY ADDRESS	For	---	P.111
	Default	192.168.1.200	
FUNCTION	For	Each connection	P.112
	Default	Operation mode: RECEIVER IP address : 192.168.1.198 PJLink : OFF PORT : 1100 PASS WORD : 20 in ASCII (Space)	
PORT NUMBER	For	Each connection	P.113
	Default	Connection 1 to Connection 3: 1100 Connection 4 to Connection 6: 23 Connection 7 to Connection 8: 80	
MAC ADDRESS	For	---	P.113
	Default	---	
HDBASET LAN	For	Each 2 HDBaseT output channels	P.113
	Default	ON	

[Table 8.14] Factory default (Cont'd)

Menu	Factory default		See
PRESET COMMAND			
COMMAND EDIT	For	Each control command	P.116
	Default	[Table 9.23] Setting control command	
RECV COMMAND EDIT	For	Each reply command	P.121
	Default	[Table 9.28] Setting reply command	
COMMAND LINK	For	Each control command execution condition	P.124
	Default	OFF	
COMMAND EXECUTION	For	---	P.126
	Default	---	
INVALID TIME	Set value	0s000ms to 999s999ms	P.126
	For	---	
	Default	0s000ms	
INITIALIZE	For	---	P.126
	Default	---	
COMMAND TALLY	For	Each control command execution key	P.127
	Default	REGISTERED	
FLASH TIME	For	Each control command execution key, each DISPLAY POWER key	P.127
	Default	EXECUTION (DISPLAY POWER key), OFF (control command execution key)	
PRESET MEMORY			
LOAD CROSS POINT	For	---	P.128
	Default	---	
SAVE CROSS POINT	For	---	P.128
	Default	---	
EDIT CROSS POINT	For	Each crosspoint memory	P.129
	Default	Video input channel : --- Audio input channel : --- Memory name : 20 (space)	
LOAD ALL SETTING	For	---	P.129
	Default	---	
SAVE ALL SETTING	For	---	P.130
	Default	---	
COPY OUTPUT MEMORY	For	---	P.131
	Default	---	
STARTUP	For	---	P.131
	Default	LAST CHANNEL	

[Table 8.15] Factory default (Cont'd)

Menu	Factory default		See
BITMAP			
BITMAP OUTPUT	For	Each output channel	P.135
	Default	OFF	
BACKGROUND COLOR	For	Each output channel, each bitmap	P.135
	Default	R : 255 G : 255 B : 255	
ASPECT	For	Each output channel, each bitmap	P.135
	Default	AUTO	
POSITION	For	Each output channel, each bitmap	P.136
	Default	CENTER	
CHANNEL ASSIGN	For	Each input channel, each output channel	P.136
	Default	OFF	
POWER ON BITMAP	For	Each output channel	P.136
	Default	OFF	
DIVIDE MEMORY* ³	For	---	P.137
	Default	MODE : RESIZE NUMBER : 1 DISPLAY : BLOCK SIZE : 127	
VIDEO CAPTURE	For	---	P.139
	Default	---	
POWER ON SETTING			
POWER SWITCH	For	---	P.141
	Default	AUTO	
DISPLAY POWER	For	Each output channel	P.142
	Default	AUTO	
COMMAND/PRESET	For	---	P.143
	Default	AUTO	
OPERATION LOCK	For	---	P.144
	Default	AUTO	

*³ The registered bitmaps are not initialized by the initialization.

[Table 8.16] Factory default (Cont'd)

Menu	Factory default		See
OTHERS			
OP LOCK MODE	For	CHANNEL MENU PRESET LOAD COMMAND DISPLAY POW OUT CH SEL	P.145
	Default	LOCK	
BUZZER	For	---	P.145
	Default	ON	
COMMAND AUTO LOCK	For	---	P.145
	Default	ON	
POWER SAVE	For	---	P.145
	Default	ON	
DISP POW BUTTON ON	For	---	P.146
	Default	0 ms	
HDC POWER OUTPUT	For	---	P.146
	Default	OFF	
INPUT CHANNEL LINK	For	---	P.147
	Default	VIDEO : OFF AUDIO : OFF	
TOP DISPLAY	For	---	P.148
	Default	NORMAL	
INPUT STATUS	For	---	P.149
	Default	---	
MONITOR STATUS	For	---	P.151
	Default	---	
EDID STATUS	For	---	P.153
	Default	---	
VERSION	For	---	P.154
	Default	---	
DANTE SETTING^{*4}			
CH61-CH64	For	---	P.155
	Default	IN8	

^{*4} Displayed only if Dante (optional feature) is installed.

[Table 8.17] Setting condition

Setting range	Description
Each output channel	Can be set for each output channel.
Each input signal	Can be set for each input signal.
Each input channel	Can be set for each input channel.
Each input channel digital input only	Can be set for each input channel only if input channel is digital signal
Each input channel analog input only	Can be set for each input channel only if input channel is analog signal
Each input channel DVI connector only	Can be set for each input channel of DVI input connector
Each RS-232C channel	Can be set for each RC-232C channel
Each connection	Can be set for each LAN connection
Each 2 HDBaseT output channels	Can be set for each 2 HDBaseT output channels MSD-6203: OUT1/OUT2, and OUT3 MSD-6204: OUT1/OUT2 and OUT3/OUT4
Each bitmap	Can be set for each bitmap

8.10 Control from WEB browser

To control the MSD from a WEB browser, enter the IP address that is programmed into the MSD in the address bar of the WEB browser to display the WEB menu. Note that the default IP address is 192.168.1.199. This default address is common among all MSD series products.

【See: 9.13.1 IP address/Subnet mask/Gateway address】

【See: 9.13.3 TCP port number】

[Table 8.18] Example URL

Port number of WEB browser	URL to be entered into address bar
80 (Normal)	http://192.168.1.199
Other than 80 (5000 to 5999)	http://192.168.1.199:5000 (e.g.: #5000)

The page mentioned below is for selecting input channels, loading preset memory, setting audio, and so on. You can open the “NAME EDIT” window by clicking the “NAME EDIT” button to name input channels, output channels, and commands.

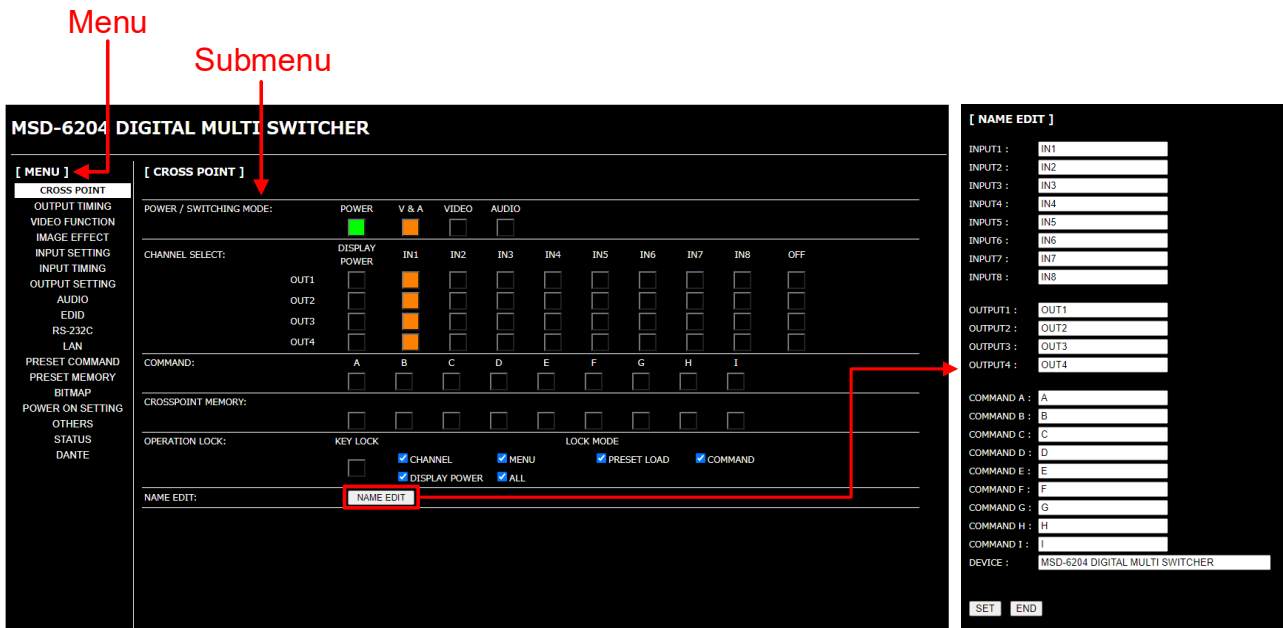

[Fig. 8.12] WEB browser page with Dante

9 Menu

9.1 Menu list

Menu tree structure for the MSD

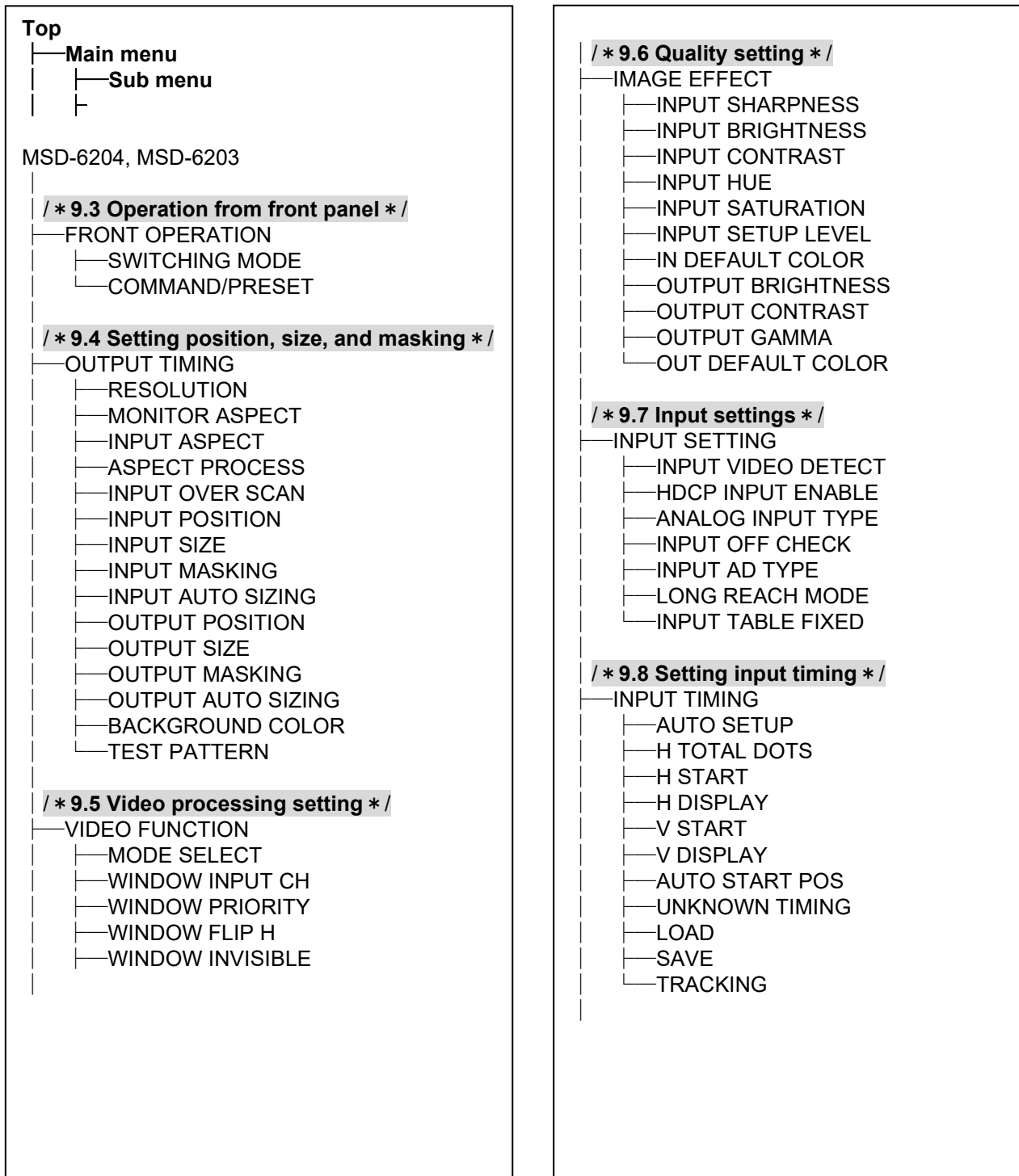

[Fig. 9.1] Menu list (1/3)

<p>/* 9.9 Output settings */</p> <ul style="list-style-type: none"> — OUTPUT SETTING <ul style="list-style-type: none"> — OUTPUT EQUALIZER — OUTPUT MODE — SYNC OUTPUT — VIDEO OUTPUT — VIDEO SWITCHING — SWITCHING SPEED — WIPE COLOR — OUTPUT CONNECTOR — HDCP OUTPUT MODE — HDCP ERROR RETRY — DEEP COLOR OUTPUT — CEC CONNECTION — HDCP AUTHORIZATION — AUTO SWITCHING ON — AUTO SWITCHING OFF — AUTO SWITCHING MASK — AUTO SWITCHING MODE — LONG REACH MODE <p>/* 9.10 Audio setting */</p> <ul style="list-style-type: none"> — AUDIO <ul style="list-style-type: none"> — OUTPUT LEVEL — OUTPUT MUTE — AUDIO INPUT SELECT — INPUT OFFSET — OUTPUT LIP SYNC — INPUT LIP SYNC — SAMPLING FREQUENCY — ANALOG OUTPUT — MULTI AUDIO — TEST TONE <p>/* 9.11 EDID */</p> <ul style="list-style-type: none"> — EDID <ul style="list-style-type: none"> — EDID DATA — PC RESOLUTION — AV RESOLUTION — DEEP COLOR INPUT — AUDIO FORMAT — SPEAKER — MONITOR EDID COPY 	<p>/* 9.12 RS-232C */</p> <ul style="list-style-type: none"> — COM PORT <ul style="list-style-type: none"> — PARAMETERS — FUNCTION — FORWARDING — FWD TX CH — FWD RX CH <p>/* 9.13 LAN */</p> <ul style="list-style-type: none"> — LAN <ul style="list-style-type: none"> — IP ADDRESS — SUBNET MASK — GATEWAY ADDRESS — FUNCTION — PORT NUMBER — MAC ADDRESS — HDBASET LAN <p>/* 9.14 Setting control command */</p> <ul style="list-style-type: none"> — PRESET COMMAND <ul style="list-style-type: none"> — COMMAND EDIT — RECV COMMAND EDIT — COMMAND LINK — COMMAND EXECUTION — INVALID TIME — INITIALIZE — COMMAND TALLY — FLASH TIME <p>/* 9.15 Preset memory */</p> <ul style="list-style-type: none"> — PRESET MEMORY <ul style="list-style-type: none"> — LOAD CROSS POINT — SAVE CROSS POINT — EDIT CROSS POINT — LOAD ALL SETTING* — SAVE ALL SETTING — COPY OUTPUT MEMORY — STARTUP <p>/* 9.16 Bitmap setting */</p> <ul style="list-style-type: none"> — BITMAP <ul style="list-style-type: none"> — BITMAP OUTPUT — BACKGROUND COLOR — ASPECT — POSITION — CHANNEL ASSIGN — POWER ON BITMAP — DIVIDE MEMORY — VIDEO CAPTURE
---	--

* Displayed if preset memory is saved.

[Fig. 9.2] Menu list (2/3)

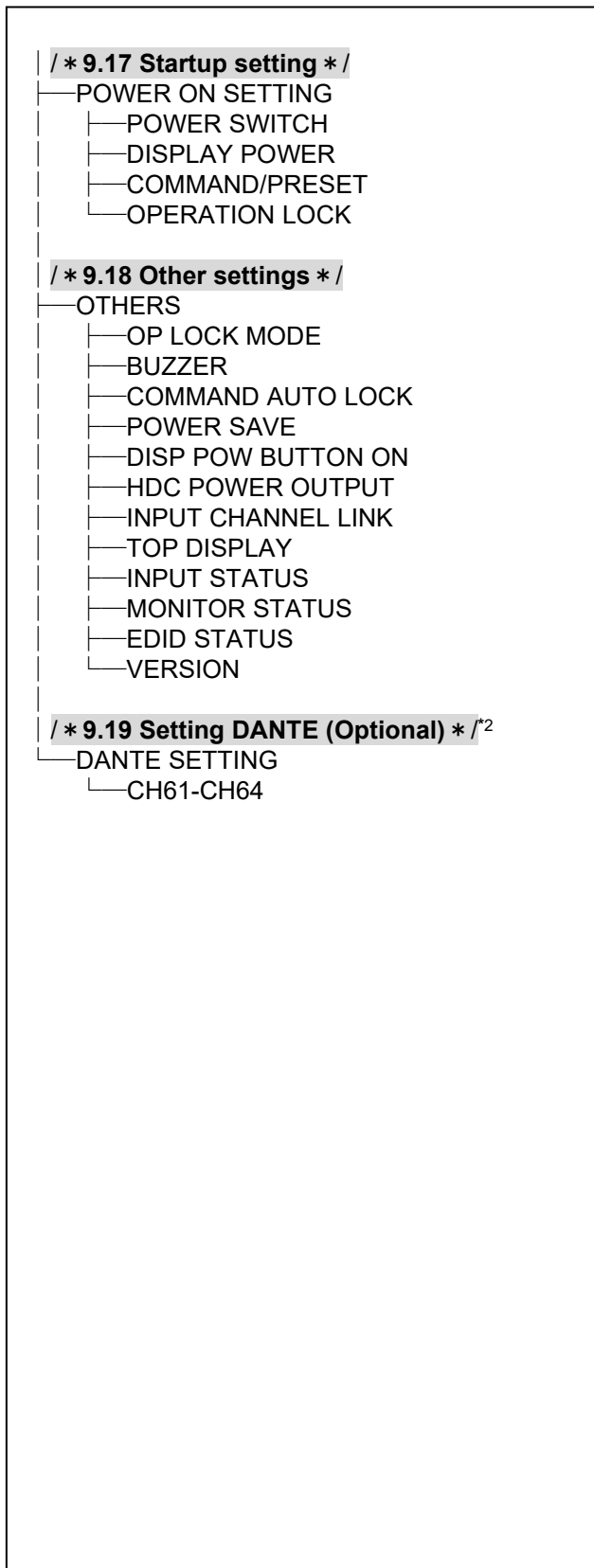

*2 Displayed only if Dante (optional) is mounted.

[Fig. 9.3] Menu list (3/3)

9.2 Input signal automatic detection

The MSD continuously monitors its input signals. If a particular signal has previously been connected to the MSD's input, the output signal will be presented in the same format as it was during the most recent session. If an input signal does not match a signal previously presented to the MSD, only the input timing settings are automatically negotiated. Other settings are not affected. The output image size and format settings can be adjusted if required.

【See: 9.4 Setting position, size, and masking】

【See: 9.6 Quality setting】

【See: 9.7.7 Fixing settings for each input signal】

【See: 9.8 Setting input timing】

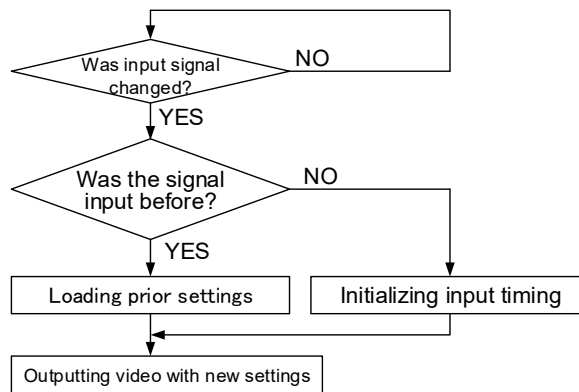

[Fig. 9.4] How input signals are recognized

The MSD retains data for up to 50 input devices for each input connector. The data is used to determine if a signal has been presented to that connector previously by a specific device. Once input data storage exceeds 50 memory locations, the new memory entry will replace the earliest less-frequent entry.

	IN1	IN2	IN3	IN4	IN5	IN6	IN7	IN8
1	1080i	1080i	UXGA	UXGA	WXGA	NTSC	NTSC	1080p
2	720p	480i	WXGA	VGA	SVGA	XGA	WXGA	WXGA
3	480i		SXGA+					
4	XGA							
5	SXGA							
6	UXGA							
⋮								
49	VGA							
50	1080p							

The MSD retains data for up to 50 devices for each input connector.

If input data storage exceeds 50 memory locations, the new memory entries will replace the earliest entries.

[Fig. 9.5] Memory table

The following attributes are saved for each input signal.

[Table 9.1] Attributes saved for each input signal

Setting	Attribute
Setting position, size, and masking	Aspect ratio, Aspect ratio control, Overscan, Display position, Display size, Masking
Quality setting	Sharpness, Brightness, Contrast, HUE, Saturation, Black level
Input settings	Analog input signal parameters
Setting input timing	The total number of horizontal dots, Start position, Active area, Automatic measurement of start position, Tracking
Audio setting*	Audio input level, Lip sync

*Audio is set automatically only if digital audio input is selected.

9.3 Operation from front panel

You can set the front panel operation modes: Channel switching mode and control command execution key.

9.3.1 Channel switching mode

Menu Top→FRONT OPERATION→SWITCHING MODE
 Setting value V&A [Default], VIDEO, AUDIO

Video and audio signals can be switched simultaneously or separately. Select a switching mode in this menu first and then switch the desired signals by pressing the front keys.

You can check the input and output setting status in the VFD screen.

[Table 9.2] Channel switching mode

Mode	Signals to be switched
V&A	Video and audio simultaneously
VIDEO	Only video
AUDIO	Only audio

9.3.2 Control command execution key operation

Menu Top→→FRONT OPERATION→COMMAND/PRESET
 Setting value COMMAND, PRESET LOAD, LOCKED [Default]

You can select the operation of the control command execution key.

COMMAND : Running control command

PRESET LOAD : Running crosspoint memory

LOCKED : Disables control command execution key

9.4 Setting position, size, and masking

Position, size, and masking attributes can be set for both the input ports and output ports of the MSD. Normally, it is preferable to set them for the input ports. If edges are cut off due to an enlarged display area by the sink device or if it is desired to modify the displayed area for all inputs at once, set the desired attributes for the output ports.

9.4.1 Output resolution

Menu Top→OUTPUT TIMING→RESOLUTION

Setting for Each output channel

Setting values

• AUTO [Default]		• 1080i@59.94 (1920x1080)	• WXGA+@60 (1440x900)
• 2160p@30(4096) (4096x2160)		• 1080i@50 (1920x1080)	• SXGA+@60 (1400x1050)
• 2160p@25(4096) (4096x2160)		• 720p@60 (1280x720)	• WXGA@60 (1366x768)
• 2160p@24(4096) (4096x2160)		• 720p@59.94 (1280x720)	• WXGA@60 (1360x768)
• 2160p@30 (3840x2160)		• 720p@50 (1280x720)	• SXGA@60 (1280x1024)
• 2160p@25 (3840x2160)		• QWXGA@60 (2048x1152)	• Quad-VGA@60 (1280x960)
• 2160p@24 (3840x2160)		• WUXGA@60 (1920x1200)	• WXGA@60 (1280x800)
• 1080p@60 (1920x1080)		• VESAHD@60 (1920x1080)	• WXGA@60 (1280x768)
• 1080p@59.94 (1920x1080)		• WSXGA+@60 (1680x1050)	• XGA@60 (1024x768)
• 1080p@50 (1920x1080)		• UXGA@60 (1600x1200)	
• 1080i@60 (1920x1080)		• WXGA++@60 (1600x900)	

The optimal resolution will be selected automatically if you set this menu to “AUTO”.

Numbers following “@” represent the vertical sync frequency.

720p/1080i/1080p/2160p are timing formats relating to the CEA-861 standard.

Others are timing formats meeting either the VESA DMT standard or the VESA CVT standard. VESAHD@60, WUXGA@60, and QWXGA@60 are output formats that incorporate Reduced Blanking.

Note:

2160p is available only if “9.5.1 Video output mode” is set to “4K MODE”.

■ “AUTO”

Automatically selects the optimal output resolution format depending on the EDID of the connected sink device. The optimal format is then provided to the connected sink device via the MSD’s output connector. The actual output resolution is displayed in parentheses. In case EDID cannot be obtained from the sink device, the resolution format that was last used is selected. This condition is indicated by an asterisk “*” to the right side of the format data.

[OUT1 RESOLUTION] ◀▶
AUTO (1080p59.94)

Outputting at optimal resolution

[OUT1 RESOLUTION] ◀▶
AUTO (1080p59.94)*

EDID cannot be loaded or optimal resolution cannot be output

9.4.2 Aspect ratio for sink device

Menu	Top→OUTPUT TIMING→MONITOR ASPECT
Setting for	Each output channel
Setting value	<ul style="list-style-type: none"> • RESOLUTION [Default] • 4:3 • 5:4 • 5:3 • 16:9 • 16:10 • 256:135

You can set the aspect ratio of the connected sink device.

If you select "RESOLUTION," the aspect ratio of the output resolution will be applied. If aspect ratios of the target sink device and the output resolution are different from each other, you can select one of the following aspect ratios for the sink device: "4:3", "5:4", "5:3", "16:9", "16:10", and "256:135" (4096x2160).

【See: 9.4.1 Output resolution】

9.4.3 Aspect ratio

Menu	Top→OUTPUT TIMING→INPUT ASPECT
Setting for	Each input channel, each input signal
Setting value	<ul style="list-style-type: none"> • AUTO-1 [Default] • 4:3 • 14:9 SIDE PANEL • AUTO-2 • 16:9 LETTER BOX • FULL • 16:9 • 14:9 LETTER BOX • THROUGH • 14:9 • 4:3 SIDE PANEL

You can set the aspect ratio for each video input.

If you select "AUTO-1" or "AUTO-2," the aspect ratio is restored automatically to the original ratio according to the settings of sink device aspect ratio and the MSD's aspect ratio control.

"AUTO-1" and "AUTO-2" work differently only when letter box signals are presented to the input. "AUTO-1" processes them as 16:9 or 14:9 video signals, while "AUTO-2" sets them as 4:3.

Normally, no problem occurs if you set the aspect ratio to "AUTO-1", but some DVD players and other devices display subtitles or setup menus outside of the normal display area. In such cases, set the aspect to "AUTO-2" to display the entire area of the video signals.

【See: 9.4.2 Aspect ratio for sink device】

【See: 9.4.4 Aspect ratio control】

Setting options: "16:9", "14:9", "4:3", "16:9 LETTER BOX", "14:9 LETTER BOX", "4:3 SIDE PANEL", and "14:9 SIDE PANEL" are accessible only when TV signals are input. When PC signals are input, the aspect ratio will be restored automatically according to the aspect ratio of the input signal regardless of the settings: "AUTO-1", "AUTO-2", "16:9", "14:9", "4:3", "16:9 LETTER BOX", "14:9 LETTER BOX", "4:3 SIDE PANEL", and "14:9 SIDE PANEL".

"FULL" : video signals are always displayed in full screen mode regardless of input video signal and settings of **"9.4.2 Aspect ratio for sink device"** and **"9.4.4 Aspect ratio control"**.

"THROUGH" : video signals are always displayed in 1:1, regardless of settings:
"9.4.2 Aspect ratio for sink device" and **"9.4.4 Aspect ratio control"**.

9.4.4 Aspect ratio control

Menu	Top→OUTPUT TIMING→ASPECT PROCESS
Setting for	Each input channel, each input signal
Setting value	L-BOX/S-PANEL : Letter box/side panel [Default] S-CUT/TB-CUT : Side cut/top bottom cut

Below is a visual description of restoring aspect ratio:

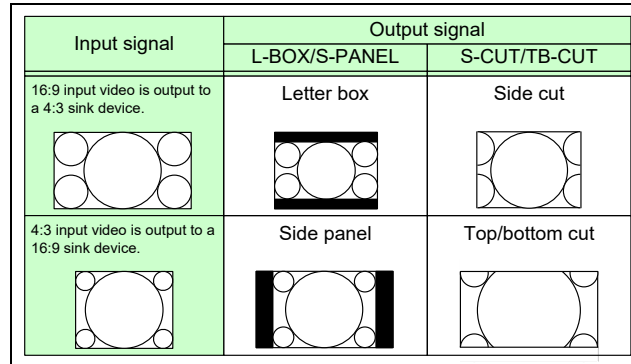

[Fig. 9.6] Restoring aspect ratio

9.4.5 Overscan

Menu	Top→OUTPUT TIMING→INPUT OVER SCAN
Setting for	Each input channel, each input signal
Setting value	100% to 115% [Default] SDTV: 105%, HDTV/PC: 100%

You can create an enlarged display of the input video.

9.4.6 Display position

Menu	Top→OUTPUT TIMING→INPUT POSITION (input side)/OUTPUT POSITION (output side)
Setting for	Input side : Each input channel, each input signal Output side: Each output channel
Setting value	

Input side:

Horizontal position (-Horizontal input size to +Horizontal output resolution [Default] 0)

Vertical position (-Vertical input size to +Vertical output resolution [Default] 0)

Output side:

Horizontal position (-Horizontal output size to +Horizontal output resolution [Default] 0)

Vertical position (-Vertical output size to +Vertical output resolution [Default] 0)

You can use these settings to change the position of the displayed video image.

Note:

If the resolution formats of each output are not the same, the resolution of OUT1 will set the precedence.

9.4.7 Display size

Menu Top→OUTPUT TIMING→INPUT SIZE (input side)/OUTPUT SIZE (output side)

Setting for Input side : Each input channel, each input signal
Output side: Each output channel (Common to OUTA/OUTB)

Setting value

Input side:

Horizontal size (Horizontal output resolution ÷4 to Horizontal output resolution x4
[Default] Horizontal output resolution)

Vertical size (Vertical output resolution ÷4 to Vertical output resolution x4
[Default] Vertical output resolution)

Output side:

Horizontal size (Horizontal output resolution ÷4 to Horizontal output resolution x4
[Default] Horizontal output resolution)

Vertical size (Vertical output resolution ÷4 to Vertical output resolution x4
[Default] Vertical output resolution)

You can use these settings to control the size of displayed video image.

The video size is scaled based on the upper left quadrant of the input video.

If you set "LINK" to "ON", only settings of "H"(Horizontal) can be set and "V" is set automatically while retaining the current aspect ratio.

【See: 9.4.6 Display position】

Notes:

- If the resolution formats of each output are not the same, the resolution of OUT1 will set the precedence.
- Numbers following "/" show the output resolution.

9.4.8 Masking

Menu Top→OUTPUT TIMING→INPUT MASKING (Input side)/OUTPUT MASKING (output side)

Setting for Input side : Each input channel, each input signal
Output side: Each output channel

Setting value

Input side:

- Left side masking (Horizontal input position to Right side masking [Default] 0)
- Right side masking (Left side masking to Horizontal input position + Horizontal input size [Default] Horizontal input size)
- Top side masking (Vertical input position to Bottom side masking [Default] 0)
- Bottom side masking (Top side masking to Vertical input position + Vertical input size [Default] Vertical input size)

Output side:

- Left side masking (Horizontal output position (0 or more) to Right side masking [Default] 0)
- Right side masking (Left side masking to Horizontal output position + Horizontal output size (Horizontal output resolution or less) [Default] Horizontal output resolution)
- Top side masking (Vertical output position (0 or more) to Bottom side masking [Default] 0)
- Bottom side masking (Top side masking to Vertical output position + Vertical output size (Vertical output resolution or less) [Default] Vertical output resolution)

You can create masks for video images. Masks can be configured to hide unnecessary portions of the displayed area (top/bottom and right/left).

9.4.9 Automatic sizing

Menu Top→OUTPUT TIMING→INPUT AUTO SIZING (Input side)/
OUTPUT AUTO SIZING (Output side)

Setting for Input side : Each input channel, each input signal
Output side: Each output channel

This function adjusts the output signal optimally, and as a result, the following settings will be populated automatically.

A long buzzer tone will sound when the initialization is completed by pressing the MENU/SET key.

[Table 9.3] Items to be initialized

Items to be initialized	Input side	Output side
Aspect ratio, overscan	Initialized	-
Display position, display size, masking	Initialized	Initialized

9.4.10 Background color

Menu	Top→OUTPUT TIMING→BACKGROUND COLOR
Setting for	Each output channel
Setting value	R/G/B: 0 to 255 [Default] R/G/B: 0 (black)

You can set the background color of output video signal.

If you set "LINK" to "ON", only the setting for "R" can be adjusted, and in this mode, "G" and "B" will automatically track the setting of "R".

9.4.11 Test pattern

Menu	Top→OUTPUT TIMING→TEST PATTERN
Setting for	Each output channel
Setting value	[Fig. 9.7] Test pattern

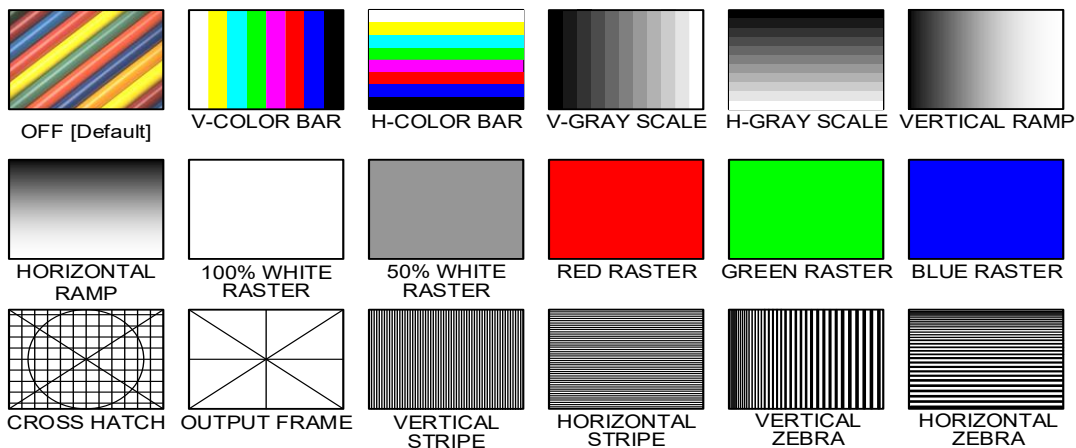

[Fig. 9.7] Test pattern

You can activate the MSD's internal test pattern generator and direct its signal to each output connector. While active, the test pattern will override any other signal that has been switched to that particular output connector. All settings pertaining to "9.6 Quality setting" will be invalid while a test pattern is displayed.

"OUTPUT FRAME": Select this pattern if part of image is not displayed on the sink device.

Setting parameters for "9.4.6 Display position" and "9.4.7 Display size" on the output side will be adjusted in order to present the test pattern appropriately on the display device.

For test patterns other than "OUTPUT FRAME": video is output on full screen with the resolution format as set in "9.4.1 Output resolution" and the settings of "9.4.6 Display position", "9.4.7 Display size", and "9.4.8 Masking" will be invalid.

You can use the arrow keys (▶, ▲, ▼) to scroll through the available patterns "COLOR BAR", "GRAY SCALE", "RAMP", and "ZEBRA". Some test patterns can be configured to scroll across the screen either vertically or horizontally. Scrolling speed can be set in increments of 3 pixels per frame. Speed can be set up to 30 pixels per frame with ▲ and ▼ keys. You can check the residual image (resolution of moving image) by displaying and scrolling the "ZEBRA" pattern.

Note:

If combination mode is set (P.69), any test pattern cannot be output.

9.5 Video processing setting

Three video output modes are available.

9.5.1 Video output mode

Menu	Top→VIDEO FUNCTION→MODE SELECT
Setting value	OFF : Normal mode [Default] OVERLAY : Video combination mode 4K MODE : 4K mode (Up to 4K@30)

You can select the video processing mode.
Press the MENU/SET key to apply the setting.

【See: 8.3.1 Normal mode】
【See: 8.3.2 Video combination】
【See: 8.3.3 4K mode】

9.5.2 Window setting [OVERLAY mode]

Menu	Top→VIDEO FUNCTION→WINDOW INPUT CH
Setting for	Each window
Setting value	OFF [Default], IN1 to IN8

If video combination mode is enabled, you can assign the input channel for each window using this menu or by operating input channel and output channel selection keys from front panel.

Note:

This feature is only for video combination mode (OVERLAY).

9.5.3 Window layer order [OVERLAY mode]

Menu	Top→VIDEO FUNCTION→WINDOW PRIORITY
Setting for	Each window
Setting value	[Table 9.4] Window layer order

[Table 9.4] Window layer order setting

Item	Value
Window	1 to 4
Priority (PRI)	1 (Highest) to 4 (Lowest)

If some or all windows are overlapped, windows are displayed according to the window priority setting as follows.

Press the MENU/SET key to apply the setting.

[Table 9.5] Window layer order

Default	Window
Priority1 (Highest)	1
Priority2	2
Priority3	3
Priority4 (Lowest)	4

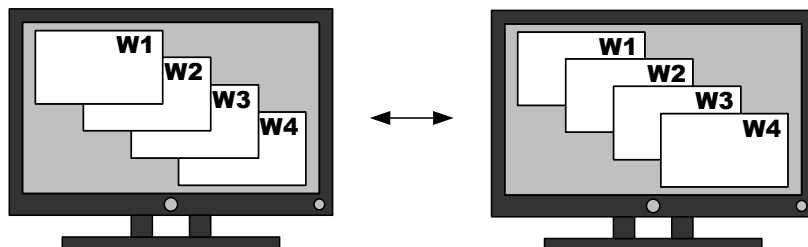

[Fig. 9.8] Window layer order

Note:

This feature is only for video combination mode (OVERLAY).

9.5.4 Horizontal flip [OFF / OVERLAY mode]

Menu	Top→VIDEO FUNCTION→WINDOW FLIP H
Setting for	Each window
Setting value	OFF : Does not flip [Default] ON : Flips horizontally

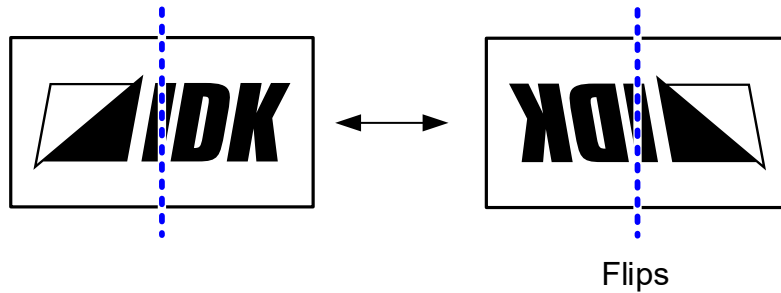

[Fig. 9.9] Flip horizontally

Note:

This feature is only for normal (OFF) mode and video combination mode (OVERLAY).

9.5.5 Window hiding

Menu	Top→VIDEO FUNCTION→WINDOW INVISIBLE
Setting for	Each window
Setting value	VISIBLE : Display [Default] INVISIBLE : Not display

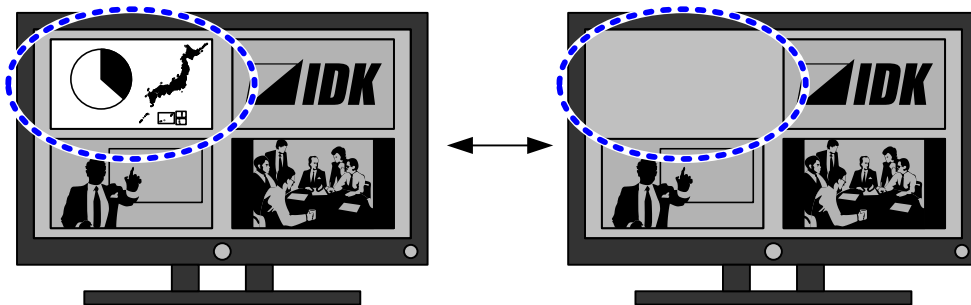

[Fig. 9.10] Hiding window

Note:

This feature is only for video combination mode (OVERLAY).

9.6 Quality setting

Setting items for input channels are for correcting color bias.

Image quality to be output can be set for each input channel and output channel as follows:

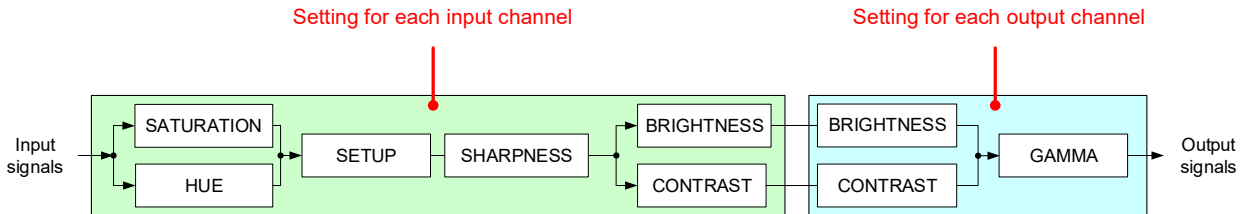

[Fig. 9.11] Video correction

9.6.1 Sharpness

Menu	Top→IMAGE EFFECT→INPUT SHARPNESS
Setting for	Each input channel, each input signal
Setting value	-5 to 15 [Default] 0

You can set the desired level of sharpness for each input signal.

9.6.2 Brightness

Menu	Top→IMAGE EFFECT→INPUT BRIGHTNESS (Input side)/ OUTPUT BRIGHTNESS (Output side)
Setting for	Input side : Each input channel, each input signal Output side: Each output channel
Setting value	80% to 120% [Default]100%

You can set the brightness level for each input/output signal.

9.6.3 Contrast

Menu	Top→IMAGE EFFECT→INPUT CONTRAST (Input side) OUTPUT CONTRAST (Output side)
Setting for	Input side : Each input channel, each input signal Output side: Each output channel
Setting value	R/G/B: 0% to 200% [Default] R/G/B: 100%

You can set the contrast for the video image.

If you set "LINK" to "ON", only the setting for "R" can be adjusted, and in this mode, "G" and "B" will automatically track the setting of "R".

9.6.4 HUE

Menu	Top→IMAGE EFFECT→INPUT HUE
Setting for	Each input channel, each input signal
Setting value	0° to 359° [Default] 0°

You can set the color HUE for each input signal.

Note:

The hue value can be set up to 359°. However, if the dot clock of input signal exceeds 165 MHz, the value is set to 0° automatically.

9.6.5 Saturation

Menu	Top→IMAGE EFFECT→INPUT SATURATION
Setting for	Each input channel, each input signal
Setting value	0% to 200% [Default] 100%

You can set the color saturation independently for each input signal.

Note:

The saturation value can be set up to 200%. However, if the dot clock of input signal exceeds 165 MHz, it is set to 100% automatically.

9.6.6 Black level

Menu	Top→IMAGE EFFECT→INPUT SETUP LEVEL
Setting for	Each input channel, each input signal
Setting value	-10.0% to 10.0% (by 0.5%) [Default] 0.0%

You can adjust the black level independently for each input signal.

9.6.7 Gamma

Menu	Top→IMAGE EFFECT→OUTPUT GAMMA
Setting for	Each output channel
Setting value	0.1 to 3.0 (by 0.1) [Default] 1.0

You can adjust the gamma curve independently or each output signal.

9.6.8 Default color

Menu Top→IMAGE EFFECT→IN DEFAULT COLOR (Input side)/
OUT DEFAULT COLOR (Output side)

Setting for Input side : Each input channel, each input signal
Output side: Each output channel

You can configure settings for the following items.

A long buzzer tone will sound when the configuration is completed by pressing the MENU/SET key.

[Table 9.6] Items to be initialized

Items to be initialized	Input side	Output side
Brightness, contrast	Initialized	Initialized
Sharpness, hue, saturation, black level	Initialized	-
Gamma	-	Initialized

9.7 Input settings

9.7.1 No-signal input monitoring

Menu	Top→INPUT SETTING→INPUT VIDEO DETECT
Setting for	Each input channel, digital input only
Setting value	OFF, 2000ms to 15000ms (100ms steps) [Default] 10000ms

If you change the EDID settings of the MSD or power the MSD off/on, the source device may not output a video signal. Use this menu to set the monitoring time. This is the interval beginning when a source device is not outputting a signal; and ending at the point when the MSD requests an output from that source device.

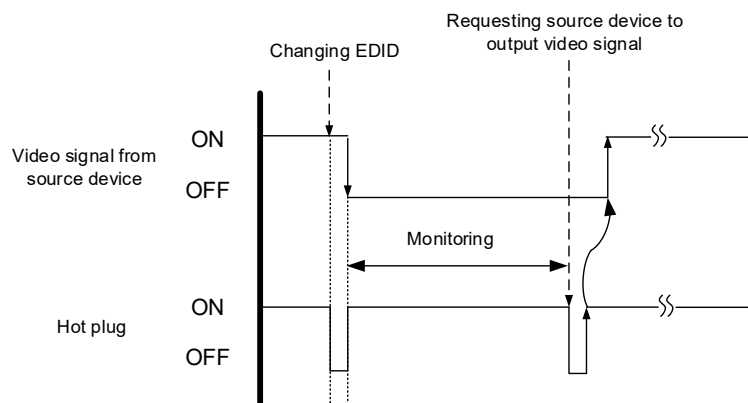

[Fig. 9.12] Monitoring absence of input

Notes:

If you are using the monitor power-saving or dual monitor features on your PC, set this feature to “OFF”. This will avoid potentially unpredictable operation.

When using this feature, ensure that the “monitoring time” is set for a value greater than the amount of time needed for the source to provide an output signal.

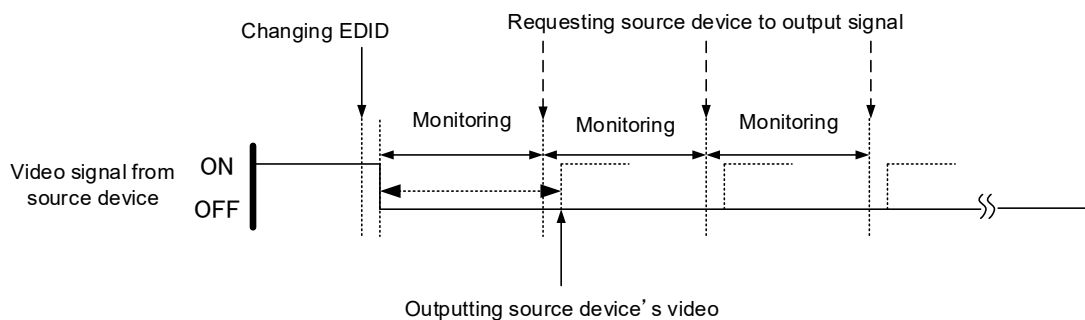

[Fig. 9.13] Repeating output reset

9.7.2 HDCP input setting

Menu	Top→INPUT SETTING→HDCP INPUT ENABLE
Setting for	Each input channel, digital input only
Setting value	HDCP1.4 : Supports HDCP 1.4 [Default] DISABLE : Not support HDCP

Some source devices negotiate with the connected device to determine if HDCP encryption is supported. After this negotiation, the source device determines whether HDCP signal encryption is enforced or not. This process takes place with some source device, even if the content being presented is not copyright protected. The MSD is HDCP compliant, if it is connected to a display device that does not support HDCP, even unprotected AV content may not be successfully displayed. Under these circumstances and if the content is indeed not protected, the problem can be solved by setting this menu to “DISABLE.” For IN7 and IN8, this menu is available if “9.7.5 Selecting signal of DVI input connector” is set to “DIGITAL”.

【See: 9.7.5 Selecting signal of DVI input connector】

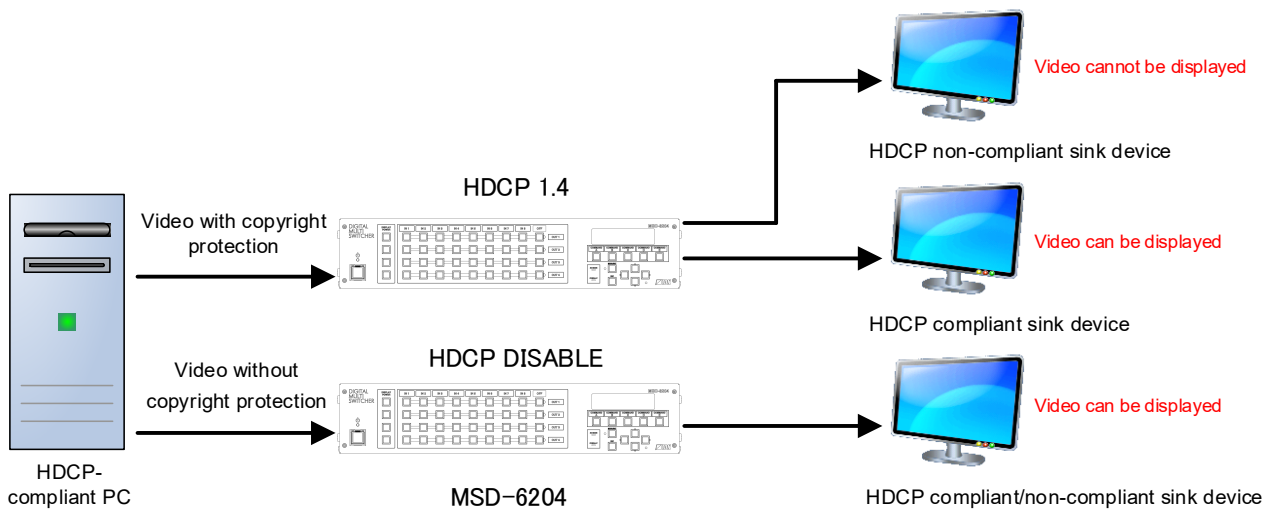

[Fig. 9.14] HDCP-compliant and HDCP non-compliant sink device

9.7.3 Analog input signal parameters

Menu	Top→INPUT SETTING→ANALOG INPUT TYPE	
Setting for	Each input channel, each input signal, analog input only	
Setting value	<ul style="list-style-type: none"> • AUTO : Automatic [Default] • YPbPr : Analog YPbPr • RGB : Analog RGB 	

You can set the type of analog video input signal.

If you select “AUTO”, the type of input signals is detected automatically. In cases where the detection fails, and video is not output correctly, set the input type manually.

For IN7 and IN8, this menu is available if “**9.7.5 Selecting signal of DVI input connector**” is set to “ANALOG”.

【See: 9.7.5 Selecting signal of DVI input connector】

9.7.4 Automatic detection of video input interruption

Menu	Top→INPUT SETTING→INPUT OFF CHECK
Setting for	Each input channel
Setting value	ON [Default], OFF

The MSD stops outputting video immediately after input video signal is disconnected even for a moment. Use this feature to minimize switching artifacts produced by an external device connected to the MSD's input connector. The effect of this function is similar to switching the MSD's input.

- **9.9.5 Window transition effect**
- **9.9.6 Window transition speed**
- **9.9.7 Wipe color**

Notes:

- If you select "ON" and are using a video input (VHS tapes or the like) with a poor quality signal, it's possible that the output will flash on and off. This is due to sync signal distortion that can be interpreted as periods of time without signal presence. In this case, set this menu to "OFF".
- Even if you set this feature to "ON", distorted video cannot be corrected completely when input video signals are lost. Especially if you set "**9.9.5 Window transition effect**" to an option other than "CUT", noises or black bars may be output at the time of fading out or transitional wiping.

9.7.5 Selecting signal of DVI input connector

Menu	Top→INPUT SETTING→INPUT AD TYPE
Setting for	Each input channel, DVI connector only
Setting value	DIGITAL [Default], ANALOG

You can select either digital or analog input signal formats.

9.7.6 HDBaseT input long reach mode

Menu	Top→INPUT SETTING→LONG REACH MODE
Setting for	HDBaseT input channel
Setting value	<ul style="list-style-type: none"> • OFF : Long reach mode disabled. Up to 328 ft. (100 m) [Default] • ON : Long reach mode enabled. Up to 492 ft. (150 m)

You can enable/disable long reach mode for HDBaseT input.

With long reach mode, up to 1080p (24 bit)/dot clock 148 MHz is supported when using with IDK's HDBaseT product. Set the MSD's EDID to 1080p or less or set the connected device's output to a supported signal format.

【See: 9.11 EDID】

9.7.7 Fixing settings for each input signal

Menu Top→INPUT SETTING→INPUT TABLE FIXED

Setting for Each input channel

Setting value

Setting mode:

- SELECTED : Sets for each item [Default]
- ALL FIXED : Does not load settings saved for each input signal but fixes the current settings

Individual setting (if “SELECTED” is selected for the setting mode):

- ASPECT : OFF [Default], ON (FIXED) 【See: 9.4.3 Aspect ratio】
- ANALOG TYPE : OFF, ON (FIXED) [Default] 【See: 9.7.3 Analog input signal parameters】
- AUDIO LEVEL : OFF, ON (FIXED) [Default] 【See: 9.10.4 Audio input level】

The MSD continuously monitors the input signals. If a particular input signal that has been presented to the MSD before is input again, the MSD will output the signal at the same size and quality as during its previous use.

【See: 9.2 Input signal automatic detection】

You can select the setting saved for each signal or the current setting.

“ALL FIXED” : Does not load all settings saved for each input signal but outputs the video with the current setting.

“SELECTED” : Aspect ratio, analog input signal type and audio input level can be set individually.
For setting items other than settings in “[Table 9.1] Attributes saved for each input signal”, settings saved for each input signal are used.

“OFF” : Settings saved for each input signal are used to format the video output.

“ON (FIXED)” : Current settings are used to format the video output.

[Table 9.7] Individual settings for each digital or analog signal

Individual setting	Digital signal (IN1 to IN8*)	Analog signal (IN7 and IN8*)
ASPECT	Can be set	Can be set
ANALOG TYPE	Cannot be set	Can be set
AUDIO LEVEL	Can be set	Cannot be set

* IN7 and IN8: Digital and analog input signals can be accommodated.

For signal selection, see “9.7.5 Selecting signal of DVI input connector”.

9.8 Setting input timing

You can set the timing parameters for analog signal inputs.

The MSD recalls the optimal table from its built-in library of tables and adjusts the input timing automatically, you typically will not need to change settings in this menu. However, if signals which are not registered in the MSD tables are introduced to the input or if part of the video image is cut off while relying on the standard table registered in the MSD, you may optimize the input timing parameters manually.

For digital inputs, you typically do not need to manually set timing parameters, but if part of the video image is cut off, you may make fine adjustments as required.

[Table 9.8] Settable items

Function	Analog input	Digital input
Automatic measurement	Partly 1	Cannot be set
The total number of horizontal dots	Partly 1, Partly 2	Partly 2
Start position	Can be set	Can be set
Active area	Can be set	Can be set
Automatic measurement of start position	Can be set	Cannot be set
Automatic setting of input timing	Can be set	Cannot be set
Loading device data	Partly 3	Can be set
Registering device data	Partly 1	Cannot be set
Tracking	Partly 1	Cannot be set

Partly 1: can be set only if analog RGB/analog YPbPr signals are input.

Partly 2: only displayed if analog video signals are input or for digital input.

Partly 3: can be set only if the device data of input signals are registered in the MSD.

9.8.1 Automatic measurement

Menu	Top→INPUT TIMING→AUTO SETUP
Setting for	Each input channel, each input signal, analog input only
Setting value	

- NORMAL MODE [Default] • 4:3 • 5:3 • 16:10
- NEXT ASPECT • 5:4 • 16:9

Analog RGB/analog YPbPr input video is measured to set “9.8.2 The total number of horizontal dots”, “9.8.3 Start position”, “9.8.4 Active area”, and “9.8.9 Tracking” automatically.

- Can be measured:
 - Input video contacts the circumscribed rectangle.
 - Brightness of input video is 25% or more.
- Cannot be measured:
 - Right and left sides of input video do not touch the circumscribed rectangle.
 - Brightness of input video is 24% or less.

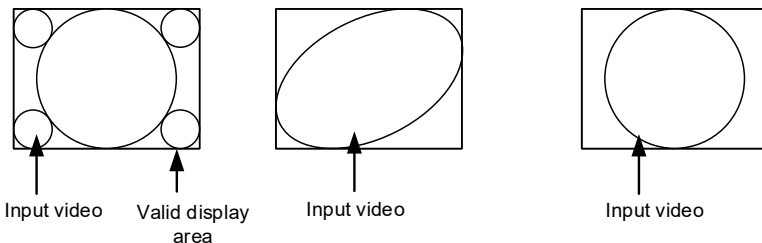

[Fig. 9.15] Conditions of automatic measurement

By selecting “NORMAL MODE”, the MSD performs automatic measurement of the start position and active area. If edges of video are not displayed correctly, use this mode to set the start position and active area automatically.

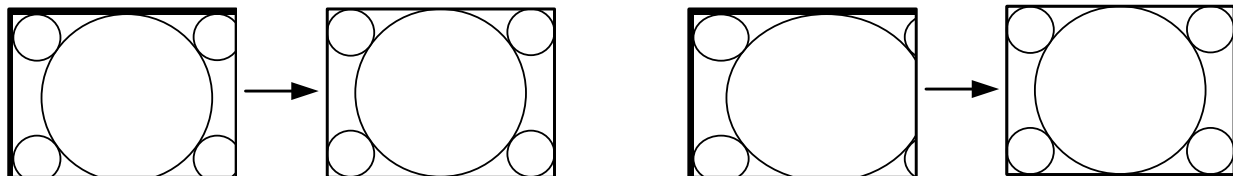

If the input video is not recognized correctly like above, it can adjust by executing “NORMAL MODE” automatic input measurement.

If the setting of active area is not correct and it cannot adjust only by start position, the active area is also adjusted by executing automatic input measurement.

[Fig. 9.16] Automatic measurement by using “NORMAL MODE”

If the total number of horizontal dots is not correct, the aspect ratio is not matched even though automatic measurement is set to “NORMAL MODE”. In this case, select “NEXT ASPECT” (Auto measurement taking into account aspect ratio) for the measurement function. If you know the aspect ratio of the input signal, you can directly specify the aspect ratio to correctly perform automatic measurement.

If the input signals are not registered in the MSD, it is recommended to use this function.

If only start position is changed, "NORMAL END" is displayed. If active area is changed if "NORMAL MODE" is selected or if "NEXT ASPECT" or aspect ratio is specified directly, the set resolution is displayed.

```
[IN8 AUTO SETUP]
1024x 768 60.00Hz
```

If there is no input signal on the selected input channel, "NOT AVAILABLE NOW" will appear on the front panel display.

Press the "MENU/SET" key to perform automatic measurement.

Note:

In case the aspect ratio does not match or the video is displayed in a position far from the correct position, set the input timing in, "9.8.2 The total number of horizontal dots", "9.8.3 Start position", and "9.8.4 Active area".

■ Operation from front keys

You can execute automatic measurement in "NORMAL MODE" by pressing the IN7 or IN8 keys (analog input only) for two seconds or longer. If you want to execute the automatic measurement in "NEXT ASPECT", press the same key for five seconds or longer.

Once automatic measurement is executed, it will be executed just by pressing the desired input channel selection key (you do not have to press and hold the key). Five seconds after the last automatic measurement, this mode will be disabled.

【See: 9.7.5 Selecting signal of DVI input connector】

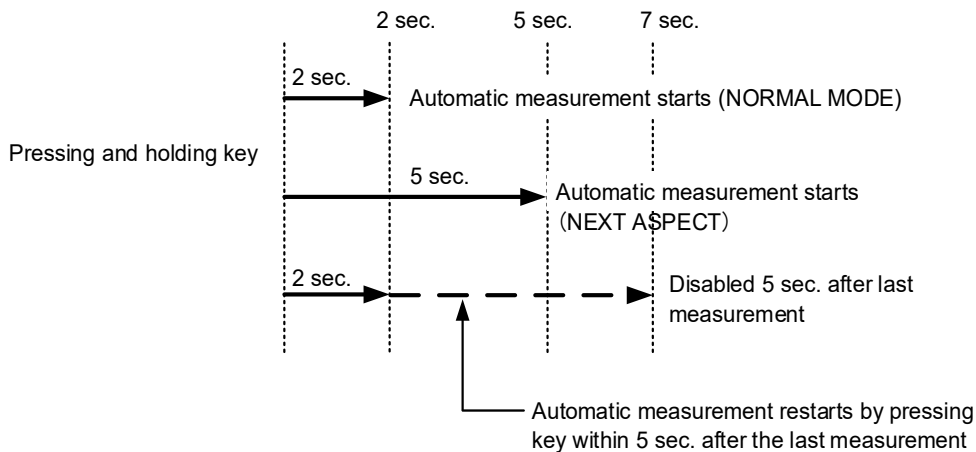

[Fig. 9.17] Automatic measurement using front key

9.8.2 The total number of horizontal dots

Menu	Top→INPUT TIMING→H TOTAL DOTS
Setting for	Each input channel, each input signal, analog input only
Setting value	400DOT to 4125DOT [Default] varies depending on the input signal

You can set the total number of horizontal dots of analog RGB/analog YPbPr input video.

The settable values vary depending on the input signal. If interlaced signals are input, the sampling clock (Horizontal synchronized frequency x the total number of horizontal dots) must be within the range of 13 MHz to 81 MHz.

If non-interlaced signal are input, the sampling clock must be within the range of 13 MHz to 162 MHz.

If other signals are input, the total number only can be displayed, but cannot be set.

If there is no input signal on the selected input channel, "NOT AVAILABLE NOW" will appear on the front panel display.

9.8.3 Start position

Menu	Top→INPUT TIMING→H START (Horizontal)/V START (Vertical)
Setting for	Each input channel, each input signal
Setting value	[Table 9.9] Settings of start position

[Table 9.9] Settings of start position

Function	Setting value
Horizontal start position	64DOT to 2900DOT (The total number of horizontal dots - Horizontal active area or less)
Vertical start position	10LINE to 2048LINE (The total number of vertical lines - Vertical active area or less)

[Default] varies depending on the input signal.

You can set the horizontal and vertical starting positions.

If the set value exceeds the limitation mentioned below the display start position will be set automatically to a value within the parametric limitation.

Horizontal : The total number of horizontal dots > Horizontal active area > Horizontal starting position

Vertical : The total number of vertical lines > Vertical active area > Vertical starting position

If 4K video signals are input, only the display start position will be displayed; the value cannot be set.

If there is no input signal on the selected input channel, "NOT AVAILABLE NOW" will appear on the front panel display.

9.8.4 Active area

Menu	Top→INPUT TIMING→H DISPLAY (Horizontal)/V DISPLAY (Vertical)
Setting for	Each input channel, each input signal
Setting value	[Table 9.10] Settings of active area

[Table 9.10] Settings of active area

Function	Setting value
Horizontal active area	64DOT to 2900DOT (The total number of horizontal dots - 64 or less)
Vertical active area	10LINE to 2048LINE (The total number of vertical lines - 10 or less)

[Default] varies depending on the input signal.

You can set the horizontal/vertical active area of input video.

For horizontal settings, the total number of horizontal dots must be greater than the number representing the horizontal active area. Manually entered settings will be automatically limited to be within the MSD's accepted value range.

If 4K video signals are input, only the active area will be displayed; the value cannot be set.

If there is no input signal on the input channel, "NOT AVAILABLE NOW" will appear on the front panel display.

9.8.5 Automatic measurement of start position

Menu	Top→INPUT TIMING→AUTO START POS
Setting for	Each input channel, each input signal, analog input only
Setting value	ALL OFF : not measuring all inputs from the input automatically OFF : not measuring the current input signal automatically ON : measuring the current input signal automatically [Default]

The MSD continually monitors analog input signals to identify the upper left portion of the image and then automatically adjusts formatting to place the image correctly on the display.

Notes:

- For motion images, some content may not be displayed full screen, and the display position may be moved each time the automatic setting measurement is applied. In such a case, set this menu to "OFF". As "OFF" and "ON" are saved for each input signal, it can be set according to the input signal. If you do not want this function for any resolution format, select "ALL OFF".
- Only the start position is set by the automatic measurement feature listed in this menu. If "9.8.2 The total number of horizontal dots" and "9.8.4 Active area" do not match, the lower right may be cut off or blackout may be output. In this case, adjust the whole screen by following "9.8.1 Automatic measurement". As the set value must not exceed the value set in "9.8.3 Start position", some video formats may be displayed with blackouts at the left side or top of the image.
- This menu is valid only if "[Fig. 9.15] Conditions of automatic measurement" is satisfactory.
- Even if you set this menu feature to "ON", manual settings will be applied and the automatic measurement is not executed if you set any of the following menus: "9.8.2 The total number of horizontal dots", "9.8.3 Start position", and "9.8.4 Active area". If you set "9.8.9 Tracking", the manual setting is applied, and tracking is not set automatically when the automatic measurement is executed. When you execute "9.8.1 Automatic measurement", setting values or this menu will be valid again.

9.8.6 Automatic setting of input timing

Menu	Top→INPUT TIMING→UNKNOWN TIMING
Setting value	AUTO SETUP ON [Default], AUTO SETUP OFF

The MSD recalls the optimal table from the library of built-in tables and sets the input timing automatically. However, if unregistered signals are input, the input timing must be set. By setting this menu feature to "AUTO SETUP ON", "9.8.1 Automatic measurement" is executed and the input timing is set automatically if signals that cannot be detected by the MSD are being introduced to a particular input for the first time.

Note:

If automatic measurement results in aspect ratio inconsistencies, perform "9.8.1 Automatic measurement" manually or set the input timing in "9.8.2 The total number of horizontal dots", "9.8.3 Start position" and/or "9.8.4 Active area".

9.8.7 Loading device data

Menu	Top→INPUT TIMING→LOAD
Setting for	Each input channel, each input signal

Device data with input timing can be loaded according to the input signal.

Press the MENU/SET key to apply the setting.

If there is no signal applied to the input channel, "NOT AVAILABLE NOW" will appear on the front panel display.

[Table 9.11] Items to be loaded

Input signal	
Analog	Registered device data will be loaded. For when: <ul style="list-style-type: none"> • The synchronous signal frequency is the same and multiple device data having different input timings are registered. • You want to set the input timing again.
Digital	The value that is automatically detected by the MSD will be set. Use this menu to restore the input timing to the original value.

9.8.8 Registering device data

Menu	Top→INPUT TIMING→SAVE
Setting for	Each input channel, each input signal, analog input only
Setting value	No. 1 to No.99

You can register up to 99 analog RGB/analog YPbPr input timing settings, and you can name each device data up to 14 characters using ASCII code 20 to 7D.

If you do not name the device table and press the MENU/SET key, the input resolution will be the device table name automatically. If the device table name is already registered and press MENU/SET key without specifying device table name, the input timing is saved to the device table name without changing the device table name.

From the next time, video will be displayed at the registered timing when the same signal is input to other channels.

Press the MENU/SET key to apply the setting.

If there is no input signal on the input channel, "NOT AVAILABLE NOW" will appear on the front panel display.

9.8.9 Tracking

Menu	Top→INPUT TIMING→TRACKING
Setting for	Each input channel, each input signal, analog input only
Setting value	0 to 63 [Default] 0

You can adjust the tracking of analog RGB/analog YPbPr input video.

If there is no input signal on the input channel, "NOT AVAILABLE NOW" will appear on the front panel display.

9.9 Output settings

9.9.1 Output equalizer

Menu Top→OUTPUT SETTING→OUTPUT EQUALIZER

Setting for Each output channel

Setting value

- OFF [Default] • LOW
- MIDDLE • HIGH

Each HDMI output connector includes an equalizer that compensates for signal attenuation when long HDMI cables are connected.

[Table 9.12] Setting output equalizer

Cable length	Shorter than 33 ft. (10 m)	33 ft. (10 m) or longer
Setting	OFF to MIDDLE	LOW to HIGH

Tip:

IDK's cable (AWG24) was used

9.9.2 Output mode

Menu Top→OUTPUT SETTING→OUTPUT MODE

Setting for Each output channel

Setting value

- HDMI YCbCr 4:4:4 MODE [Default] • HDMI RGB MODE
- HDMI YCbCr 4:2:2 MODE • DVI MODE

You can select an output signal mode and color space of the output video.

The MSD selects the optimal output mode for the connected sink device according to the following priority table:

Higher priority	HDMI YCbCr 4:4:4 MODE
↑	
↓	
Lower priority	DVI MODE

Note:

If "DVI MODE" is selected, the DVI signal can be output at a resolution format of 1080p, QWXGA, or lower. For other resolutions, the signal is output in the optimal format for the sink device.

9.9.3 Synchronous signal output with no input video

Menu	Top→OUTPUT SETTING→SYNC OUTPUT
Setting for	Each output channel
Setting value	ON [Default], OFF

You can set whether synchronous signal is always output.

If you set this menu to “ON”, you can prevent the sink device from being switched into standby mode.

Note:

In “video combination” mode, a synchronous signal is always output, regardless of this menu’s setting.

9.9.4 Output video with no input video

Menu	Top→OUTPUT SETTING→VIDEO OUTPUT
Setting for	Each output channel
Setting value	· BLUE [Default] · BACKGROUND COLOR · BLACK

You can set video to be output when no video signal is being presented to the selected input.

Set “9.9.3 Synchronous signal output with no input video” to “ON” in order to apply this menu’s setting.

9.9.5 Window transition effect

Menu	Top→OUTPUT SETTING→VIDEO SWITCHING	
Setting for	Each output channel	
Setting value	<ul style="list-style-type: none"> • FREEZE→FADE OUT-IN [Default] • FADE OUT-IN • CUT • BOTTOM→TOP WIPE • TOP→BOTTOM WIPE • RIGHT→LEFT WIPE • LEFT→RIGHT WIPE 	

You can select a window transition effect for when the video inputs are switched.

If “**9.7.4 Automatic detection of video input interruption**” is set to “ON” and input signal is disconnected, this setting will be applied.

Note:

In “video combination” mode, “WIPE” cannot be selected. If “WIPE” is already selected, the setting will automatically default to “FREEZE→FADE OUT-IN”.

9.9.6 Window transition speed

Menu	Top→OUTPUT SETTING→SWITCHING SPEED	
Setting for	Each output channel	
Setting value	100ms to 2000ms (per 10ms) [Default] 350ms	

You can set the window transition speed for FADE OUT/IN or WIPE OUT/IN when input channels are switched.

The setting will also be applied when “**9.7.4 Automatic detection of video input interruption**” is set to “ON”.

9.9.7 Wipe color

Menu	Top→OUTPUT SETTING→WIPE COLOR	
Setting for	Each output channel	
Setting value	R/G/B: 0 to 255 [Default] R/G/B: 0 (black)	

You can set the wipe color.

If you set “LINK” to “ON”, only Red (R) setting values can be changed. Setting values for Green (G) and Blue (B) will automatically be changed according to the settings of the Red (R).

9.9.8 Output connector

Menu	Top→OUTPUT SETTING→OUTPUT CONNECTOR
Setting for	Each output channel
Setting value	HDMI [Default], HDBaseT

The MSD outputs video to the HDMI output or HDBaseT output. You can set a desired connector.

9.9.9 HDCP output

Menu	Top→OUTPUT SETTING→HDCP OUTPUT MODE
Setting for	Each output channel
Setting value	ALWAYS : Encrypts HDCP at all times regardless of input signal status [Default] DCP INPUT ONLY: Encrypts HDPC only if input signal has HDCP DISABLE : Do not encrypt HDCP

You can set the HDCP encryption of the HDMI output connector.

Normally set this function to “ALWAYS”.

If you select “HDCP INPUT ONLY”, the MSD encrypts HDCP only if the input signal has HDCP. However, if an input is changed from on channel to another and HDCP authentication status is changed, the MSD starts HDCP authentication again. This action may temporarily delay the output of video and audio.

If you select “DISABLE”, the MSD never encrypts HDCP. In this mode, only input signals without HDCP can be output from the MSD.

If a sink device which does not support HDCP is connected, the MSD can only output video and audio signals which do not have HDCP, regardless of this menu’s setting.

9.9.10 The number of HDCP retries

Menu	Top→OUTPUT SETTING→HDCP ERROR RETRY
Setting for	Each output channel
Setting value	ETERNITY: retries until succeed [Default] 0 to 100 : 0 to 100times

You can set the number of HDCP retries.

If an HDCP-compliant sink device is connected and you set **“9.9.9 HDCP output”** to “ALWAYS” or “HDCP INPUT ONLY”, HDCP is authorized regardless of the status of input signal. Normally, set this menu to “ETERNITY” to retry the authentication automatically after the first authentication fails. However, you can set the number of retries manually. (If retry is not succeeded even after the MSD retries for the set number of retry times, video and audio with HDCP are not output.)

Press the MENU/SET key to apply the setting.

9.9.11 Deep Color

Menu	Top→OUTPUT SETTING→DEEP COLOR OUTPUT
Setting for	Each output channel
Setting value	24-BIT COLOR [Default] 30-BIT COLOR

You can select the color depth of HDMI signal.

“30-BIT COLOR”: signals are output with “30-BIT COLOR” only if a sink device supporting Deep Color is connected.

Since the transmission clock of “30-BIT COLOR” is faster than that of “24-BIT COLOR”, noise may occur if a poor-quality cable or long cable is connected. In those cases, the noise may be removed by selecting “24-BIT COLOR”.

For 4K (3840 x 2160) and 4K (4096 x 2160), the color depth is “24-BIT COLOR”.

9.9.12 CEC connection

Menu Top→OUTPUT SETTING→CEC CONNECTION

Setting for Each output channel

Setting value

- NOT CONNECTED [Default] • SELECTED CHANNEL
- IN1 to IN6

You can set the CEC connection for when a CEC-supported device is connected to HDMI input connector. Press the MENU/SET key to apply the setting.

Notes:

- Using CEC may cause negative effects. If you do not use CEC, set this menu to “NOT CONNECTED”. If the status of the sink devices connected to the HDMI output connector changes (such as being powered OFF→ON) or if the CEC connection changes, the EDID may also need to be changed (the MSD changes it automatically) to update the address of the connected device. When the EDID is changed, the source device stops outputting video temporarily.
- CEC connections take place on a one-to-one basis. CEC does not support inputs and outputs. If you set multiple outputs to connect to the same input, only the channel with the lowest numerical value will be connected. The other outputs will not be connected.

9.9.13 HDCP re-authentication

Menu Top→OUTPUT SETTING→HDCP AUTHORIZATION

Setting for Each output channel

If an HDCP-compliant sink device is connected, HDCP is authorized automatically. You can re-authorize HDCP manually using this function. Press the MENU/SET key to perform the re-authentication.

9.9.14 Priority of input channel automatic switching

Menu	Top→OUTPUT SETTING→AUTO SWITCHING ON/AUTO SWITCHING OFF
Setting for	Each output channel
Setting value	[Table 9.13] Setting of priority of input channel automatic switching

[Table 9.13] Setting of priority of input channel automatic switching

Item	Set value	Default
Output channel (OUT)	1 to 4	-*
Input channel (IN)	1 to 8	-*
Priority (PRI)	1 (high) to 8(low), OFF	OFF

*Setting input channel priority for each output channel

■ AUTO SWITCHING ON:

Automatically selects the input channel whenever its signal input status changes from OFF to ON.

The MSD switches input signals automatically as follows:

- When input signal status of a channel changes from “OFF” to “ON” and that input channel has the same or a higher priority level than the currently-selected channel.

or

- When video is not input to the current input channel having higher priority than the input channel that changes from “OFF” to “ON”.

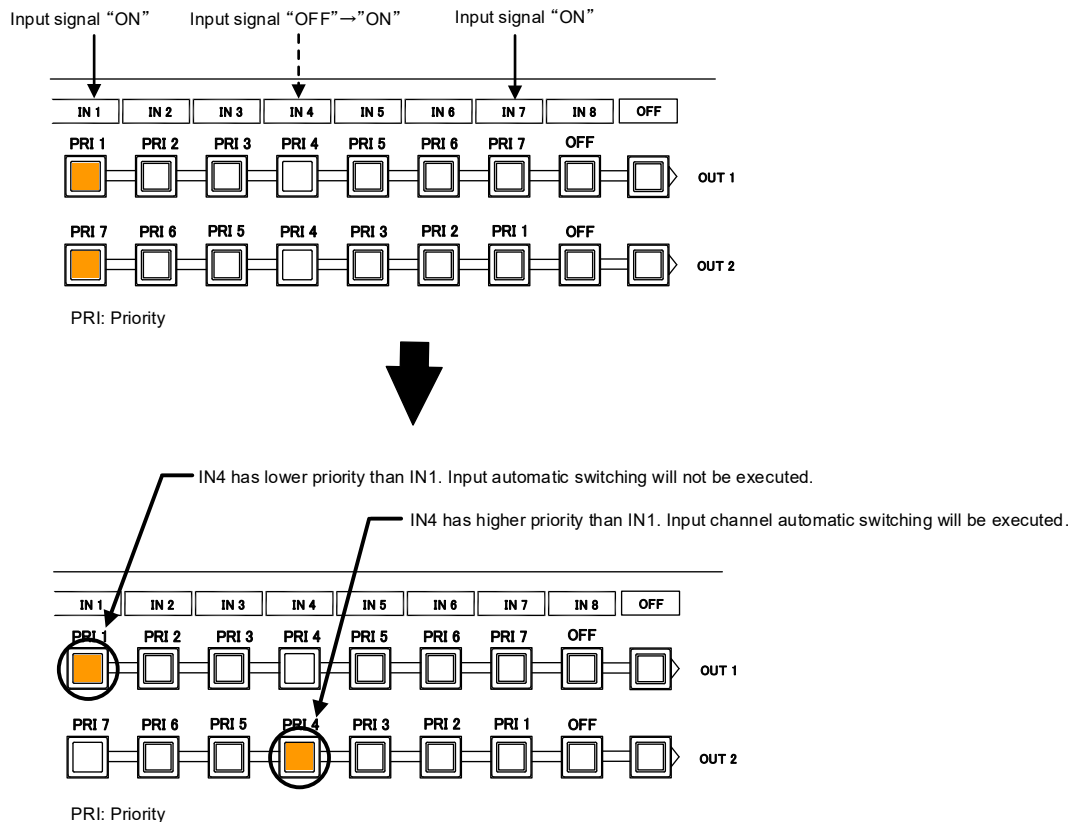

[Fig. 9.18] Input channel automatic switching “OFF” to “ON”

■ AUTO SWITCHING OFF:

Selects alternate input channel when the input signal of currently-selected channel changes from “ON” to “OFF”.

The MSD switches input signal automatically as follows:

- Switches to the input channel having input signal and highest priority.
- If some channels have the same priority, the MSD switches to the lower numbered input channel having an active input signal.

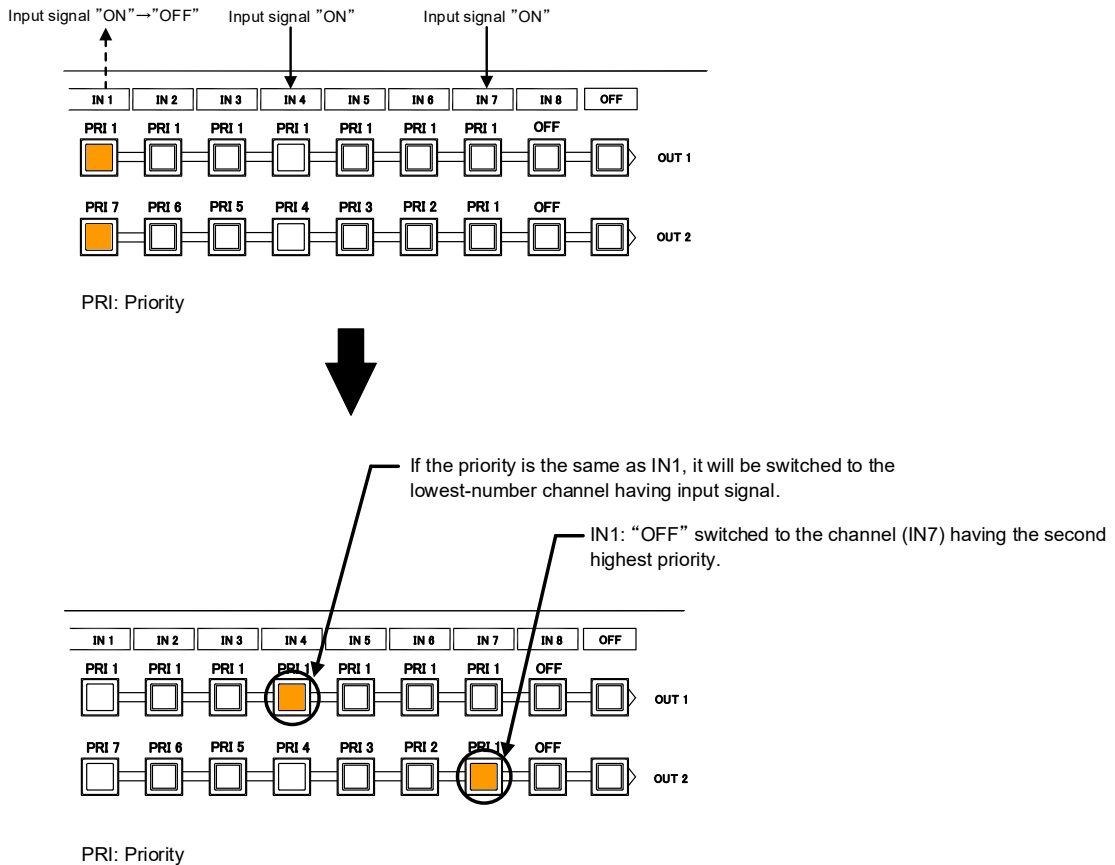

[Fig. 9.19] Input channel automatic switching “ON” to “OFF”

For channels whose “PRI” is set to “OFF”, automatic switching is not executed.

You can set the automatic switching mode for input channel in **“9.9.16 Channel switching mode of automatic switching”**.

Press the MENU/SET key to apply the setting.

9.9.15 Ignoring duration after automatic switching

Menu	Top→OUTPUT SETTING→AUTO SWITCHING MASK
Setting for	Each output channel
Setting value	0s000ms to 999s999ms [Default] 0s000ms

You can set the time from when input channel is switched automatically until when the next automatic switching is performed. The automatic switching is not performed during the set time.

【See: 9.9.14 Priority of input channel automatic switching】

9.9.16 Channel switching mode of automatic switching

Menu	Top→OUTPUT SETTING→AUTO SWITCHING MODE
Setting for	Each output channel
Setting value	V&A (Video & Audio) [Default], VIDEO (Video), AUDIO (Audio)

You can set the channel switching mode when automatic switching is executed. This setting has priority regardless of setting of “8.2 Selecting input channels”.

【See: 9.9.14 Priority of input channel automatic switching】

9.9.17 HDBaseT output long reach mode

Menu	Top→OUTPUT SETTING→LONG REACH MODE
Setting for	HDBaseT output channel
Setting value	ON : Long reach mode ON Up to 492 ft. (150 m) OFF : Long reach mode OFF Up to 328 ft. (100 m) [Default]

You can enable/disable HDBaseT output long reach mode.

Long reach mode: Up to 1080p (24 bit)/dot clock 148 MHz is supported when using with IDK's HDBaseT product. Select a supported output format.

【See: 9.4.1 Output resolution】

【See: 9.9.11 Deep Color】

9.10 Audio setting

HDMI digital audio supports formats mentioned in the table below. Set the audio depending on device connected to the HDMI output connector.

Only “2-channel LPCM” can be input by default. If you want to use “Multi-channel LPCM” or bit stream signal, set “Audio format” and “Speaker configuration”.

【See: 9.11.5 Audio format】

【See: 9.11.6 Speaker configuration】

[Table 9.14] Audio format

Audio format	Description
2-channel LPCM	2ch, 32 kHz to 192 kHz, 16/20/24 bit
Multi-channel LPCM	8ch, 32 kHz to 192 kHz, 16/20/24 bit
AC-3, Dolby Digital, DTS, Dolby Digital+, DTS-HD, Dolby TrueHD, AAC	Bit stream

■ If multi-channel LPCM signal is input to digital audio:

For sink device and analog audio that do not support multi-channel LPCM signal, 2-channels (ch) that are set in “9.10.8 Multi-channel audio output” or down mixed audio will be output.

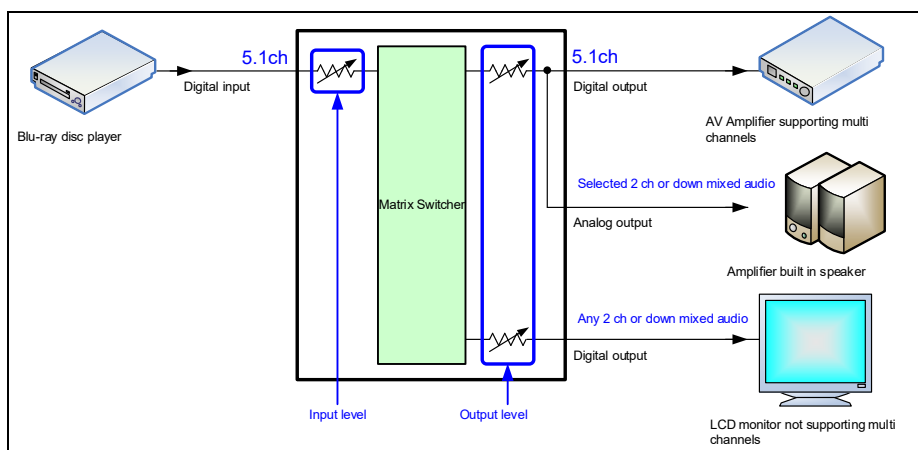

[Fig. 9.20] Multi-channel LPCM input

■ If bit stream signal is input to digital audio:

Input audio is output to digital audio connector. It is not output to analog audio; audio volume cannot be adjusted.

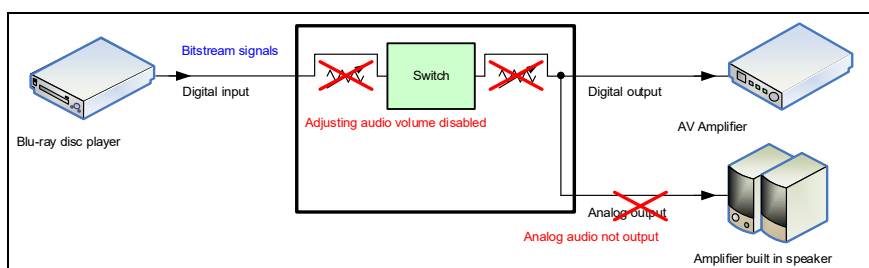

[Fig. 9.21] Bit stream signal input

9.10.1 Output level

Menu	Top→AUDIO→OUTPUT LEVEL
Setting for	Each output channel
Setting value	-60dB to 10dB [Default] 0dB

You can set the audio output level.

If you change the output level while the audio output mute is set to “ON”, it will be unmuted.

If you set “**9.18.8 Top page**” to “AUDIO VOLUME”, you can change the output level from the top page.

9.10.2 Output mute

Menu	Top→AUDIO→OUTPUT MUTE
Setting for	Each output channel
Setting value	OFF [Default], ON

You can mute/unmute the output audio.

If you set “**9.18.8 Top page**” to “AUDIO VOLUME”, you can change the mute setting.

9.10.3 Selecting audio input

Menu	Top→AUDIO→AUDIO INPUT SELECT
Setting for	Each input channel
Setting value	DIGITAL [Default], ANALOG1, ANALOG2

You can select digital or analog audio input to be output.

DIGITAL: Outputs embedded audio from HDMI input. IN7 and IN8 do not output audio

if “**9.7.5 Selecting signal of DVI input connector**” is set to “ANALOG”.

ANALOG1 and ANALOG2: Output audio that is input to analog audio input connector 1 or 2.

9.10.4 Audio input level

Menu	Top→AUDIO→INPUT OFFSET
Setting for	Each input channel, each input signal
Setting value	-60dB to 0dB [Default] 0dB

You can set the audio input level.

You can correct the gap in audio input levels of each input signal, since audio input levels can be set for each input port.

9.10.5 Lip sync

Menu	Top→AUDIO→OUTPUT LIP SYNC (Output side)/INPUT LIP SYNC (Input side)
Setting for	Output side: Each output channel Input side : Each input channel, each input signal
Setting value	0FRAME to 8FRAME [Default] 0FRAME

You can adjust the time gap between video (motion) and audio (sound).

Up to eight frames (up to 16 frames in total) can be set for each input/output channel.

If sampling frequency is 192 kHz and vertical synchronous frequency is 24 Hz/25 Hz/30 Hz, the total maximum values of lip sync input/output channel are as follows:

[Table 9.15] Maximum lip sync value

Sampling frequency	Vertical sync frequency	Lip sync maximum value
192 kHz	24 Hz	Up to 8 frames*
	25 Hz	Up to 8 frames*
	30 Hz	Up to 10 frames*
Other conditions		Up to 16 frames

*Up to 8 frames can be set for each input/output channel lip sync, but lip sync is limited to the maximum value.

9.10.6 Sampling frequency

Menu	Top→AUDIO→SAMPLING FREQUENCY		
Setting for	Each output channel		
Setting value	· AUTO [Default]	· 96kHz	· 48kHz
	· 192kHz	· 88.2kHz	· 44.1kHz
			· 32kHz

You can set the sampling frequency of digital audio output.

■ “AUTO”

Digital audio is output at the maximum sampling frequency supported by the sink device that is connected to the HDMI output connector. The output signal's sampling frequency is displayed in parentheses. In case EDID cannot be read from the sink device, the sampling frequency that was used the last time is selected with “*” on its right side.

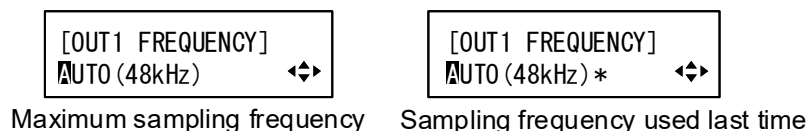

9.10.7 Analog audio output connector

Menu Top→AUDIO→ANALOG OUTPUT

Setting for Audio output connector

Setting value

- OUT1: Outputs audio of output channel 1 to the analog audio output connector [Default]
- OUT2: Outputs audio of output channel 2 to the analog audio output connector
- OUT3: Outputs audio of output channel 3 to the analog audio output connector
- OUT4: Outputs audio of output channel 4 to the analog audio output connector

You can set the audio of the selected output channel to the analog audio output connector.

9.10.8 Multi-channel audio output

Menu Top→AUDIO→MULTI AUDIO

Setting for Each output channel

Setting value

- | | | |
|----------------------|------------------|----------------|
| • DOWN MIX [Default] | • CH5/CH6 STEREO | • CH3/CH4 MONO |
| • CH1/CH2 STEREO | • CH7/CH8 STEREO | • CH5/CH6 MONO |
| • CH3/CH4 STEREO | • CH1/CH2 MONO | • CH7/CH8 MONO |

You can select audio to be output to a sink device that does not support multi-channel LPCM or analog audio for when multi-channel LPCM audio is input from an HDMI input connector.

You can select audio from “DOWN MIX” (multi-channel audio is down mixed), “STEREO” (stereo audio), or “MONO” (monaural audio).

9.10.9 Test tone

Menu Top→AUDIO→TEST TONE

Setting for Each output channel

Setting value

Test tone:

OFF [Default] 1kHz, 400Hz

Speaker:

- ALL [Default]
- FRONT L/R
- REAR L/R
- REAR L/R CENTER
- FRONT LEFT
- FRONT RIGHT
- LOW FREQUENCY EFFECT (LFE)
- FRONT CENTER
- REAR LEFT
- REAR RIGHT
- REAR LEFT CENTER
- REAR RIGHT CENTER

You can check the position of the speakers, since test tone can be output only to specific speakers.

For “LOW FREQUENCY EFFECT”, only test tone of 30 Hz is output.

【See: 9.11.6 Speaker configuration】

9.11 EDID (Extended Display Identification Data)

You can set EDID to be sent to the source device and can edit parameters as needed.

■ Setting EDID

Step 1 : If you use copied EDID, copy the target EDID from the sink device.

Step 2 : Set the EDID that will be sent to the source device.

Step 3 : If you use built-in EDID, customize the data as required.

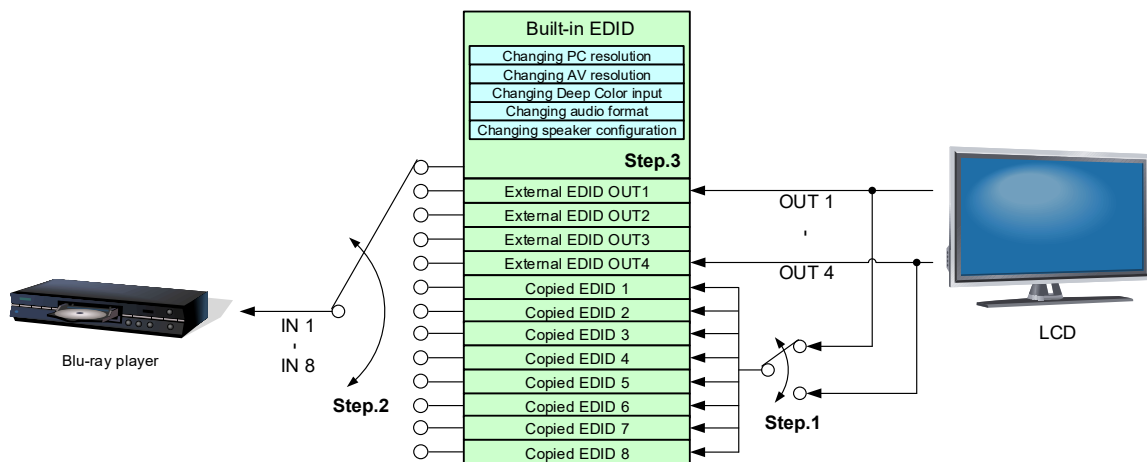

[Fig. 9.22] Setting EDID (MSD-6204)

9.11.1 EDID

Menu Top→EDID→EDID DATA

Setting for Each input channel, digital input only

Setting value

- INTERNAL EDID [Default]
- OUT1 MONITOR
- OUT2 MONITOR
- OUT3 MONITOR
- OUT4 MONITOR
- COPY DATA1 to COPY DATA8

You can set the EDID to be sent to the source device from built-in EDID (“INTERNAL EDID”), connected sink device’s EDID (“MONITOR”) and copied EDID (“COPY DATA”).

EDID copied from a sink device will be displayed if any.

Press the MENU/SET key to apply the setting.

【See: 9.11.7 Copying EDID】

9.11.2 Resolutions for PCs

Menu Top→EDID→PC RESOLUTION

Setting for Each input channel

Setting value

- SVGA (800x600)
- XGA (1024x768)
- 720p (1280x720)
- WXGA (1280x768)
- WXGA (1280x800)
- Quad-VGA (1280x960)
- SXGA (1280x1024)
- WXGA (1360x768)
- WXGA (1366x768)
- SXGA+ (1400x1050)
- WXGA+ (1440x900)
- WXGA++ (1600x900)
- UXGA (1600x1200)
- WSXGA+ (1680x1050)
- 1080i (1920x1080)
- 1080p (1920x1080)
- WUXGA (1920x1200)
- QWXGA (2048x1152)
- WQHD (2560x1440)
- WQXGA (2560x1600)
- 2160p@30 (3840x2160)

[Default] IN1 to IN8: 1080p (1920x1080)

You can set the resolution format that will be requested from the source device.

WQHD (2560x1440), WQXGA (2560x1600), 2160p@30 (3840x2160): can be selected for IN1, IN5, and IN6. In 4K mode, the set resolution's EDID will be applied. In normal mode and video combination mode, 1080p's EDID will be applied automatically.

This setting will also be applied for controlling output resolution when AV devices (such as Blu-ray players) are connected via HDMI.

For digital input, this setting will be valid only if "INTERNAL EDID" is selected for "9.11.1 EDID".

Press the MENU/SET key to apply the setting.

Timing of 720p, 1080i, 1080p, and 2160p is the same as that of HD signal meeting the CEA-861 standard.

For other resolutions, timing parameters meet the VESA DMT or VESA CVT standards.

The maximum available resolution is set for EDID, but the lower resolutions are also supported.

Select the resolution supported by the connected PC.

You can select 2160p (4096x2160) resolution in "9.11.3 Input resolution for AV devices".

[Table 9.16] Supported resolution

Input resolution setting \ Supported resolution	640x480	800x600	1024x768	1280x720	1280x768	1280x800	1280x960	1280x1024	1360x768	1366x768	1400x1050	1440x900	1600x900	1600x1200	1680x1050	1920x1080i	1920x1080p	1920x1200	2048x1152	2560 x 1440	2560 x 1600	2160p (30p)
800x600	Y	Y	N	N	N	N	N	N	N	N	N	N	N	N	N	N	N	N	N	N	N	N
1024x768	Y	Y	Y	N	N	N	N	N	N	N	N	N	N	N	N	N	N	N	N	N	N	N
1280x720[D4]	Y	Y	Y	Y	N	N	N	N	N	N	N	N	N	N	N	N	N	N	N	N	N	N
1280x768	Y	Y	Y	Y	Y	N	N	N	N	N	N	N	N	N	N	N	N	N	N	N	N	N
1280x800	Y	Y	Y	Y	Y	Y	N	N	N	N	N	N	N	N	N	N	N	N	N	N	N	N
1280x960	Y	Y	Y	Y	Y	Y	Y	N	N	N	N	N	N	N	N	N	N	N	N	N	N	N
1280x1024	Y	Y	Y	Y	Y	Y	Y	Y	N	N	N	N	N	N	N	N	N	N	N	N	N	N
1360x768	Y	Y	Y	Y	Y	Y	Y	Y	Y	N	N	N	N	N	N	N	N	N	N	N	N	N
1366x768	Y	Y	Y	Y	Y	Y	Y	Y	N	Y	N	N	N	N	N	N	N	N	N	N	N	N
1400x1050	Y	Y	Y	Y	N	Y	Y	Y	N	Y	Y	N	N	N	N	N	N	N	N	N	N	N
1440x900	Y	Y	Y	Y	N	Y	Y	Y	N	Y	Y	Y	N	N	N	N	N	N	N	N	N	N
1600x900	Y	Y	Y	Y	N	Y	Y	Y	N	Y	Y	Y	Y	N	N	N	N	N	N	N	N	N
1600x1200	Y	Y	Y	Y	N	Y	Y	Y	N	Y	Y	Y	Y	Y	N	N	N	N	N	N	N	N
1680x1050	Y	Y	Y	Y	N	Y	Y	Y	N	Y	Y	Y	Y	Y	Y	N	N	N	N	N	N	N
1920x1080i[D3]	Y	Y	Y	Y	N	N	N	N	N	N	N	N	N	N	N	Y	N	N	N	N	N	N
1920x1080p[D5]	Y	Y	Y	Y	N	N	Y	Y	N	Y	Y	Y	Y	Y	Y	N	Y	N	N	N	N	N
1920x1200	Y	Y	Y	N	N	Y	Y	Y	N	N	Y	Y	Y	Y	Y	N	Y	Y	N	N	N	N
2048x1152	Y	Y	Y	N	N	N	Y	Y	N	N	Y	Y	Y	Y	Y	N	Y	Y	Y	N	N	N
2560x1440	Y	Y	Y	N	N	N	Y	Y	N	N	Y	Y	Y	Y	Y	N	Y	N	Y	Y	N	N
2560x1600	Y	Y	Y	N	N	N	N	Y	N	N	Y	Y	Y	Y	Y	N	Y	N	Y	Y	Y	N
2160p (30p)	Y	Y	Y	N	N	N	N	Y	N	N	Y	Y	Y	Y	Y	N	Y	N	Y	N	Y	Y

Y: Supported, N: Not supported

9.11.3 Input resolution for AV devices

Menu Top→EDID→AV RESOLUTION

Setting for Each input channel, digital input only

Setting value

- AUTO [Default] • 720p • 2160p@30
- UNUSED • 1080i • 4096x2160@30
- 480p • 1080p

You can set the resolution requested to be output from AV devices (such as Blu-ray players).

“2160p@30”, “4096x2160@30”: can be selected for IN1, IN5, and IN6.

This setting is applied if “**9.11.1 EDID**” is set to “INTERNAL EDID”.

Normally, set this menu to “AUTO” to set resolution for AV devices according to “**9.11.2 Resolutions for PCs**” automatically.

“UNUSED” disables the EDID for AV devices. If you select “AUTO” and the resolution output from the PC is different from the resolution set in Properties, the problem may be solved by selecting “UNUSED”.

If there is a possibility that both PCs and AV devices with different resolutions will be connected to a particular input port, set the PC resolution in “**9.11.2 Resolutions for PCs**” and select the AV resolution in this menu. However, some PCs and AV devices may select the higher resolution of the resolutions set in “**9.11.2 Resolutions for PCs**” and this menu.

If a source device that does not support 4K is connected to the input connector with 4K EDID settings, the source device may output DVI signal meaning audio is not output. In order to output HDMI signal from the source device, change the settings of this menu and “**9.11.2 Resolutions for PCs**” to a value other than 4K.

Press the MENU/SET key to apply the setting.

[Table 9.17] Input resolutions in “AUTO” mode

Resolution for PC	640×480	800×600	1024×768	1280×720	1280×768	1280×800	1280×960	1280×1024	1360×768	1366×768	1400×1050	1440×900	1600×900	1600×1200	1680×1050	1920×1080i	1920×1080p	1920×1200	2048×1152	2560×1440	2560×1600	2160@30
Resolution for AV	480p		720p													1080i	1080p			2160p@30		

Notes:

- If you select “UNUSED”, the settings of “**9.11.4 Deep Color**”, “**9.11.5 Audio format**”, “**9.11.6 Speaker configuration**” will be disabled and audio is not output because the source device outputs signal through DVI mode.
- Signals may not be output at 4K depending on contents and AV devices.

9.11.4 Deep Color

Menu	Top→EDID→DEEP COLOR INPUT
Setting for	Each input channel, digital input only
Setting value	24-BIT COLOR [Default] 30-BIT COLOR

You can set the color depth to be output from the source device.

This menu is valid only if you select "INTERNAL EDID" for "9.11.1 EDID" and you select a resolution other than "UNUSED" for "9.11.3 Input resolution for AV devices".

If you select "30-BIT COLOR", compared to "24-BIT COLOR", "30-BIT COLOR" is transmitted using a higher clock frequency. The clock frequency may cause noise if a poor-quality or an excessively long cable is connected. In such a case, the noise may be removed by setting the color to "24-BIT COLOR".

Press the MENU/SET key to apply the setting.

9.11.5 Audio format

Menu	Top→EDID→AUDIO FORMAT
Setting for	Each input channel, digital input only
Setting value	[Table 9.18] Audio format

[Table 9.18] Audio format

Audio format	ON/OFF	Maximum sampling frequency (kHz)
PCM	Cannot be set	32/44.1/48/88.2/96/176.4/192 (48)
Dolby Digital	Can be set (OFF)	ON: 32/44.1/48 (48)
AAC	Can be set (OFF)	ON: 32/44.1/48/88.2/96 (48)
Dolby Digital+	Can be set (OFF)	ON: 32/44.1/48 (48)
DTS	Can be set (OFF)	ON: 32/44.1/48/96 (48)
DTS-HD	Can be set (OFF)	ON: 44.1/48/88.2/96/176.4/192 (192)
Dolby TrueHD	Can be set (OFF)	ON: 44.1/48/88.2/96/176.4/192 (96)

Default values are shown in parentheses.

You can set the audio format and maximum sampling frequency to be output from a source device.

This menu will be valid only if you select "INTERNAL EDID" for "9.11.1 EDID" and you select a resolution other than "UNUSED" for "9.11.3 Input resolution for AV devices".

Press the MENU/SET key to apply the setting.

9.11.6 Speaker configuration

Menu	Top→EDID→SPEAKER
Setting for	Each input channel, digital input only
Setting value	Setting mode : AUTO [Default], MANUAL Each speaker : ON, OFF The number of speakers: 1 to 8

[Table 9.19] Default speaker configuration

The number of speakers	FL/FR	LFE	FC	RL/RR	RC	FLC/FRC	RLC/RRC	FLW/FRW	FLH/FRH	TC	FCH
1	OFF	OFF	ON	OFF	OFF	OFF	OFF	OFF	OFF	OFF	OFF
2 [Default]	ON	OFF	OFF	OFF	OFF	OFF	OFF	OFF	OFF	OFF	OFF
3	ON	ON	OFF	OFF	OFF	OFF	OFF	OFF	OFF	OFF	OFF
4	ON	ON	ON	OFF	OFF	OFF	OFF	OFF	OFF	OFF	OFF
5	ON	ON	OFF	ON	OFF	OFF	OFF	OFF	OFF	OFF	OFF
6	ON	ON	ON	ON	OFF	OFF	OFF	OFF	OFF	OFF	OFF
7	ON	ON	ON	ON	ON	OFF	OFF	OFF	OFF	OFF	OFF
8	ON	ON	ON	ON	OFF	OFF	ON	OFF	OFF	OFF	OFF

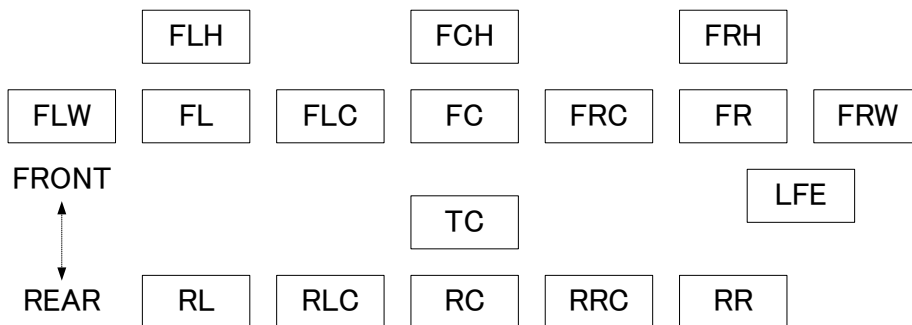

FL	Front Left	RRC	Rear Right Center
FC	Front Center	LFE	Low Frequency Effect
FR	Front Right	FLW	Front Left Wide
FLC	Front Left Center	FRW	Front Right Wide
FRC	Front Right Center	FLH	Front Left High
RL	Rear Left	FCH	Front Center High
RC	Rear Center	FRH	Front Right High
RR	Rear Right	TC	Top Center
RLC	Rear Left Center		

[Fig. 9.23] Speaker configuration

You can set the speaker configuration for multi-channel audio.

This menu is valid only if you select “INTERNAL EDID” for “**9.11.1 EDID**”, you select a resolution other than “UNUSED” for “**9.11.3 Input resolution for AV devices**”.

If you select “AUTO” for the setting mode and set the number of speakers, the speaker configuration will be set to the default setting that is shown in “[Table 9.19] Default speaker configuration”.

To change the default configuration, set the mode to “MANUAL” and set each speaker to ON/OFF individually. If the number of speakers exceeds the available value, the “DATA INVALID” message is displayed and the settings will not be applied.

Press the MENU/SET key to apply the setting.

9.11.7 Copying EDID

Menu	Top→EDID→MONITOR EDID COPY
Setting for	COPY EDID No.1 to No.8
Setting value	

EDID of the sink device is loaded and registered to the MSD.

Up to eight EDID profiles can be registered.

■ Copying EDID (Ex: MSD-6204)

- Step.1 : Select output channel (OUT1 to OUT4) which is connected to sink device
- Step.2 : Select the number of COPY EDID (No.1 to No.8)
- Step.3 : Set the name of the EDID using ASCII code 20 to 7D (up to 10 characters)
- Step.4 : Press the “MENU/SET” key to register an EDID

9.12 RS-232C

The RS-232C connector of the MSD can output communication command control from PCs and control commands from the MSD to external/peripheral devices or equipment. The operation mode will be switched according to “9.12.2 RS-232C operation mode”.

【See: 9.14 Setting control command】

9.12.1 RS-232C communication setting

Menu Top→COM PORT→PARAMETERS
 Setting for RS-232C channel
 Setting value [Table 9.20] RS-232C setting items

【Table 9.20】 RS-232C setting items

Setting item	Setting value	Default
Baud rate [bps]	4800, 9600, 19200, 38400	9600
Data bit length [bit]	8, 7	8
Parity check	NONE, EVEN, ODD	NONE
Stop bit [bit]	1, 2	1

You can set the RS-232C communication parameters.
 Press the MENU/SET key to apply the setting.

9.12.2 RS-232C operation mode

Menu Top→COM PORT→FUNCTION
 Setting for RS-232C channel
 Setting value RECEIVER [Default], TRANSMITTER

You can set the operation mode of the MSD's RS-232C port to either “RECEIVER” mode, enabling the MSD to be is controlled externally via RS-232C, or “TRANSMITTER” mode, enabling the MSD to control peripheral devices via RS-232C.

Press the MENU/SET key to apply the setting.

9.12.3 RS-232C HDBaseT connection

Menu	Top→COM PORT→FORWARDING
Setting for	RS-232C channel
Setting value	OFF [Default], ON

You can set the communication between MSD's RS-232C connector and RS-232C connectors of HDBaseT transmitters or receivers that is connected to HDBaseT I/O connector.

If setting this menu to "ON", RS-232C communication data can be transmitted from a PC that is connected to the RS-232C connector to HDBaseT transmitter (connected to the HDBaseT input connector) and receiver (connected to RS-232C output connector).

9.12.4 RS-232C transmitting channel

Menu	Top→COM PORT→FWD TX CH
Setting for	Each HDBaseT output channel, each HDBaseT input channel
Setting value	OFF [Default], ON

You can select destination connectors to which RS-232C communication data is sent from a PC connected to RS-232C.

This menu is available if "9.12.3 RS-232C HDBaseT connection" is set to "ON".

9.12.5 RS-232C receiving channel

Menu	Top→COM PORT→FWD RX CH
Setting value	OUT1B [Default], OUT2B to OUT4B, IN5 to IN6

You can select the source connector from which RS-232C communication data is sent to a PC (connected to RS-232C).

9.13 LAN

The internal switching hub enables connections between the MSD's LAN connector and LAN connectors of twisted pair cable transmitters and receivers that are connected to HDBaseT I/O connectors. Bidirectional communication is also available.

Communication command control from PC to the MSD and control command output from the MSD to external devices can be executed from all LAN ports. Operation mode will be switched according to the setting of "9.13.2 LAN operation mode". The MSD has eight connections that can be set individually.

【See: 9.14 Setting control command】

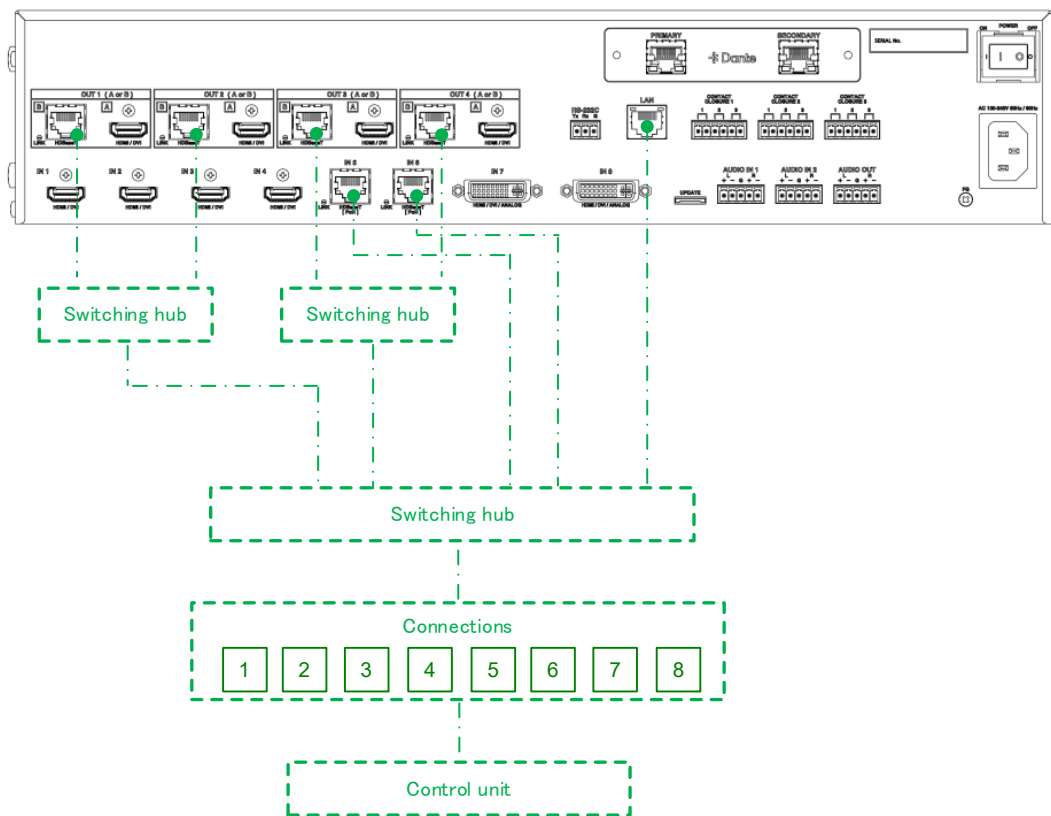

[Fig. 9.24] LAN configuration (Example: MSD-6204 with Dante)

The MSD does not support automatic acquisition of IP address using DHCP (Dynamic Host Configuration Protocol). If you use the MSD in a network with DHCP, use a fixed IP address. If controlling peripheral devices connected over LAN from the MSD, use multiple fixed IP addresses.

Note:

HDBaseT output connector is enabled only if "9.9.8 Output connector" is set to HDBaseT.

■ LAN loop problem

The MSD includes switching hub function. The network may be down due to loop problem.

If the loop problem occurs, set “9.13.5 Setting HDBaseT LAN” to “OFF”.

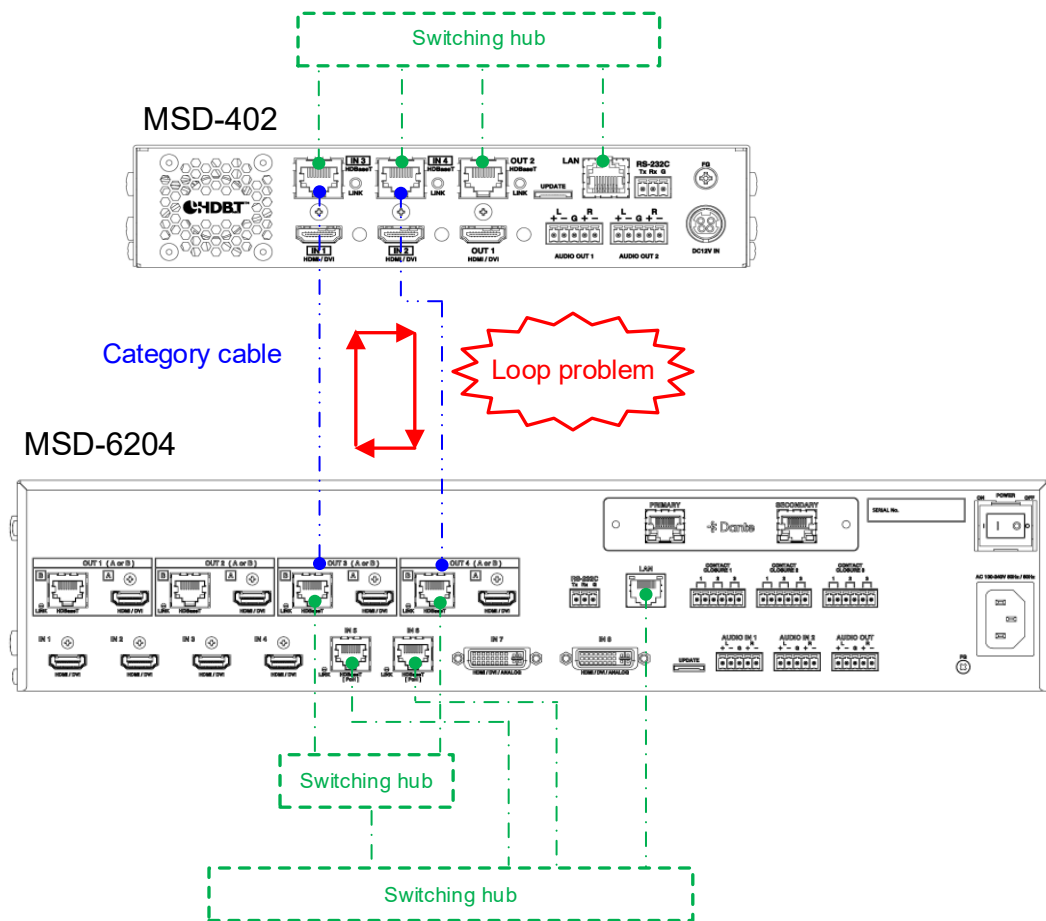

[Fig. 9.25] Loop problem with IDK's device (Example: MSD-6204 with Dante)

Note:

The LAN function of the HDBaseT input connector is set to ON and cannot be set to OFF.

9.13.1 IP address/Subnet mask/Gateway address

Menu	IP address	: Top→LAN→IP ADDRESS
	Subnet mask	: Top→LAN→SUBNET MASK
	Gateway address	: Top→LAN→GATEWAY ADDRESS
Setting value	[Default] IP address	: 192.168.1.199
	Subnet mask	: 255.255.255.0
	Gateway address	: 192.168.1.200

You can set the IP address, subnet mask, and gateway address.

Press the MENU/SET key to apply the setting.

9.13.2 LAN operation mode

Menu	Top→LAN→FUNCTION
Setting for	Each connection
Setting value	[Table 9.21] Setting LAN operation mode

[Table 9.21] Setting LAN operation mode

Setting item	Operation mode	
	Receiver mode	Transmitter mode
Operation mode	RECEIVER [Default]	TRANSMITTER
Destination IP address	N/A	0.0.0.0 to 255.255.255.255 [Default] 192.168.1.198
PJLink protocol connection	N/A	ON : Use OFF: Not use [Default]
Destination connection number* ¹	N/A	1 to 65535 [Default] 1100
PJLink protocol password* ²	N/A	20, 30 to 39, 41 to 5A, 61 to 7A in ASCII code (in hex) [Default] 20 (space)

*¹ For PJLink protocol connections, the target port number is fixed at "4352".

*² For PJLink protocol connections, the maximum permissible number of characters is 32.

If you do not want password authentication, you do not have set a password.

You can set the LAN operation mode to either "RECEIVER" mode that controls the MSD externally or "TRANSMITTER" mode that controls peripheral devices from the MSD.

If you select "TRANSMITTER" mode, you need to set the parameters to support the connected device that will be controlled.

Press the MENU/SET key to apply the setting.

9.13.3 TCP port number

Menu	Top→LAN→PORT NUMBER
Setting for	Each connection
Setting value	[Table 9.22] TCP port number

[Table 9.22] TCP port number

For	Setting value
Communication command control	23, 1100, 6000 to 6999
WEB browser control	80, 5000 to 5999

[Default] Connections 1 to 3 = 1100; Connections 4 to 6 = 23;
Connections 7, 8 = 80

You can set the TCP port number to control the MSD externally.

This setting will be valid if "RECEIVER" is selected for "9.13.2 LAN operation mode".

Each connection will be divided into connections for communication command control and WEB browser depending on the set port numbers.

Press the MENU/SET key to apply the setting.

9.13.4 MAC address

Menu	Top→LAN→MAC ADDRESS
------	---------------------

You can display the MSD's MAC address.

9.13.5 Setting HDBaseT LAN

Menu	Top→LAN→HDBASET LAN
Setting for	Each 2 HDBaseT output channels MSD-6203: OUT1/OUT2, and OUT3 MSD-6204: OUT1/OUT2 and OUT3/OUT4
Setting value	ON [Default], OFF

You can enable/disable the LAN capabilities of each HDBaseT output connector.

【See: 9.13 LAN】

Note:

Reboot the MSD to apply the setting.

9.14 Setting control command

You can control external devices (for example, powering ON/OFF projectors) via RS-232C, LAN, contact closure, or CEC. You can register up to 32 commands in the MSD. Registered control commands will be associated with control command execution keys (COMMAND A to COMMAND I) or execution conditions such as switching video or audio.

When execution trigger conditions are met, those commands will be performed in the prescribed order. The loop back function allows you to control the MSD itself.

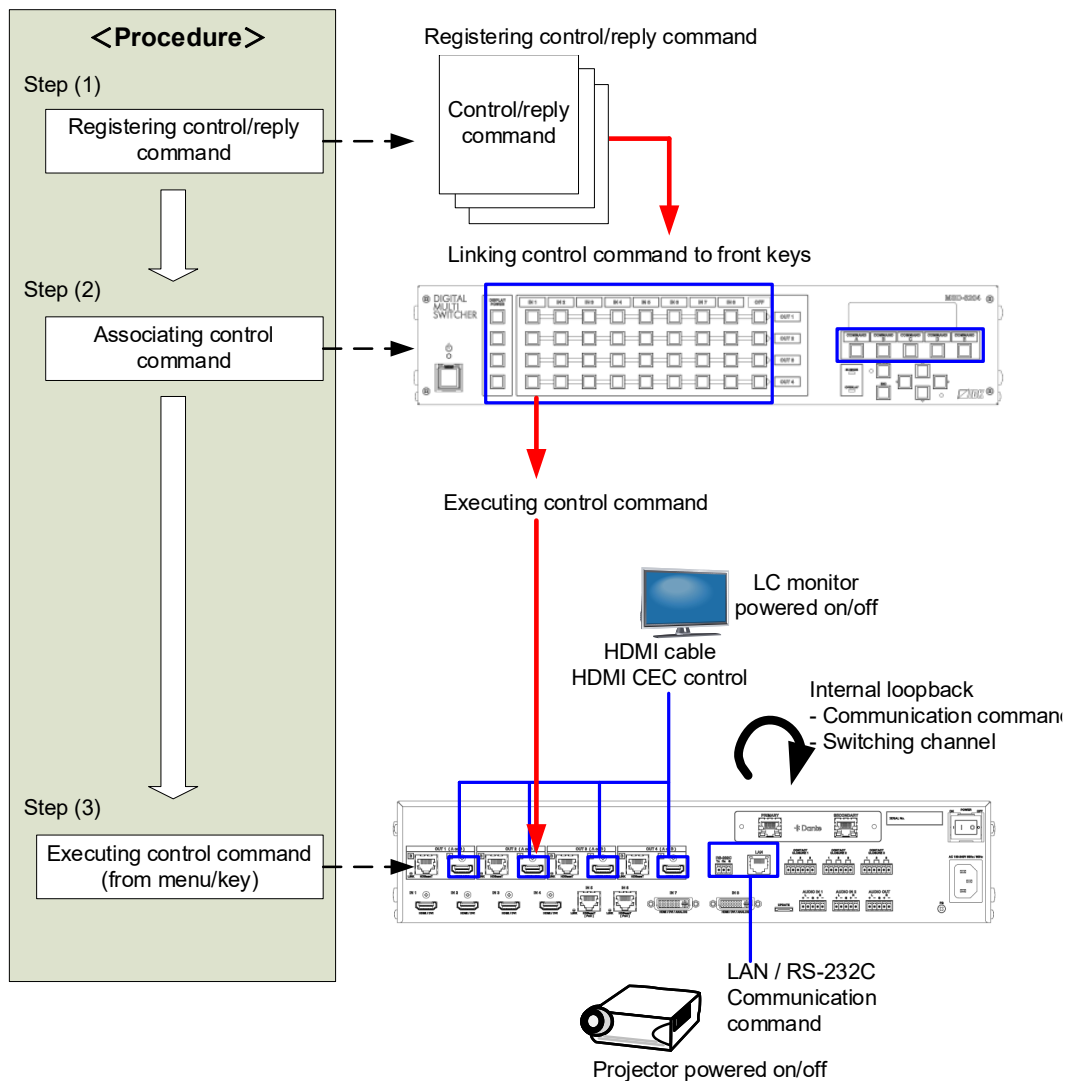

[Fig. 9.26] Executing control command (Example: MSD-6204 with Dante)

Note:

Functions of control command execution keys (COMMAND A to COMMAND E) change depending on menu selection (selecting control command execution key).

- COMMAND : Registered control commands are executed.
- PRESET LOAD: Registered crosspoint memory is loaded.
- LOCK : Control command execution keys are locked.

[See: 9.17.3 Control command execution key]

■ Control command via RS-232C/LAN communication

Control commands can be sent from MSD's RS-232C connector, LAN connector, or HDBaseT output connector.

Before executing control command, set the operation mode of the connector to "TRANSMITTER".

【See: 9.12.2 RS-232C operation mode】

【See: 9.13.2 LAN operation mode】

■ Screen display during control command execution

When a control command is executed, "MEMO" text registered for a control command is displayed (1). If the reply command is received, the "MEMO" text registered for the reply command is also displayed (2) for one second (when the control command that is used for checking the reply command is executed).

The received data is displayed (3) for two seconds (when the control command that is used for displaying the received data is executed).

Examples:

- (1) "SCREEN UP" is registered in MEMO and the control command is executed.
- (2) A reply command, "SCREEN OK", is displayed.
- (3) "PROJECTOR LAMP" is registered in the MEMO and "%1LAMP=1000 1↵" is received.
- (4) Reply command could not be received and retry over occurs.

(1) Only control command

```
SEND: SCREEN UP
```

(2) Control command (upper)
Reply command (lower)

```
SEND: SCREEN UP
RECV: SCREEN OK
```

(3) Received data is displayed.

```
SEND: PROJECTOR LAMP
RECV: %1LAMP=1000 1↵
```

(4) Reply command cannot be
received and a retry error occurs.

```
SEND: SCREEN UP
RETRY OVER ERROR
```

[Fig. 9.27] VFD screen

If you configure multiple control commands, or if you display data received from multiple com ports, the display time may be shortened by one to two seconds while control commands are being successively executed. If the received data does not fit in the full screen, the displayed data is scrolled.

9.14.1 Registering/editing control command

Menu Top→PRESET COMMAND→COMMAND EDIT

Setting for Each command

Setting value [Table 9.23] Setting control command

You can register and edit up to 32 control commands.

Press the MENU/SET key to apply the setting.

[Table 9.23] Setting control command

Setting item	COM	CC	CEC	Description	Range
PORT	yes	yes	yes	Select "COM", "CC" or "CEC".	COM : Communication command [Default] CC : Contact closure CEC : HDMI CEC control
COM SIZE	yes	no	no	Set the number of bytes to be sent starting with the first byte.	0BYTE to 30BYTE [Default] 0BYTE
DELAY	yes	yes	yes	Set the waiting time to issue control commands. Use this item for devices such as projectors that requires time to cool down after powering off.	0ms to 999s999ms [Default] 0ms
Communication port	yes	no	no	Set the following communication ports to "OFF" (not sending communication commands) or "ON" (sending communication commands). Those ports can be set separately, and communication commands can be sent to multiple communication ports at the same time. - RS : RS-232C ⁵ - LOOP BACK : Internal loop back - LAN1 to LAN8 : LAN connection 1 to 8 ⁶ - IN5 to IN6 : HDBaseT input 5 to 6 - OUT1 to OUT4 : HDBaseT output 1 to 4	OFF : Not sending reply command [Default] ON : Sending reply command
COMMAND INPUT MODE	yes	no	no	Set the input mode of send command data. Select "ASCII" if "DATA" of "COMMAND" consists of only 0A, 0D, and 20 to 7D of ASCII codes. Select "HEX" if "DATA" of "COMMAND" includes other codes.	ASCII [Default] HEX
Send command data	yes	no	no	Set the command from the first byte according to the number of bytes set in "COM SIZE" (up to 30 bytes).	0A, 0D, 20 to 7D in ASCII, 00 to FF in hex [Default] 20 (space)

[Table 9.24] Setting control command (Cont'd)

Setting item	COM	CC	CEC	Description	Range
RECV DISPLAY	yes	no	no	Set whether received data is displayed or not.	OFF [Default] ASCII HEX
DELIMITER ^{*1}	yes	no	no	Set the delimiter to be sent at the end of the received data. "NONE": delimiter is not checked and all received data within the set timeout will be valid. Value other than "NONE": delimiter is checked and data received before delimiter will be valid.	NONE : Not checking delimiter [Default] 00 to FF (Hex)
RCV CHECK ^{*2}	yes	no	no	Set whether reply command that may be returned is checked or not.	CHECK NOT CHECK [Default]
TIME OUT ^{*3 *4}	yes	no	no	Set the timeout delay for reply command to a sent command.	0ms to 99s999ms [Default] 0ms
RETRY ^{*3 *4}	yes	no	no	Set the number of retries to resend the same command again if no valid response is received.	0 to 99 (times) [Default] 0
INTERVAL ^{*3 *4}	yes	no	no	Set the retry interval to resend the command.	0ms to 99s999ms [Default] 0ms
ERROR ^{*3 *4}	yes	no	no	Set whether the next command is to be executed or not if no valid response is replied, even after completing retry for the set number of retries.	STOP [Default] EXEC : Continue
Contact closure control	no	yes	no	Set the contact closure control. If you select "toggle operation", it can invert the condition of contact (open/close).	- : Not controlling contact closure [Default] OFF : Opening contact ON : Closing contact TGL : Toggle
Pulse width	no	yes	no	Set the time of returning its original condition when you control the contact closure.	NONE : Eternity [Default] 100ms to 9990ms (by 10ms)
HDMI CEC control ^{*7}	no	no	yes	Set the CEC control for the sink devices connected to OUT1 to OUT4.	- : Not controlling CEC [Default] POWER OFF POWER ON
Process for CEC error	no	no	yes	Set whether the next command is executed or not if no response is replied from the sink device that is controlled with CEC.	STOP [Default] EXEC : Continue
MEMO	yes	yes	yes	Register a note containing up to 14 characters. The registered note is displayed when the control command is executed.	20 to 7D in ASCII codes except for 2C (,) [Default] 20 (space)

- *1 If you set "RECV DISPLAY" to "OFF", you cannot set this item.
- *2 If you set "RECV DISPLAY" to "ASCII" or "HEX", you cannot set this item.
- *3 If you set only "LOOP BACK" for communication ports to "ON", you do not need to set this item.
- *4 If you set all "RCV CHECK" to "NOT CHECK", you do not need to set this item.
- *5 If you set "RS: RS-232C" to "ON", set "**9.12.2 RS-232C operation mode**" to "TRANSMITTER".
- *6 If you set any LAN connections for "LAN1" to "LAN8" to "ON", set "**9.13.2 LAN operation mode**" to "TRANSMITTER".
- *7 CEC: only power ON/OFF of the sink device can be controlled.

■ Setting loop back function

The MSD sends a communication command back to the MSD itself using the loop back function. It replies "OK" if processed normally while replying "NG" if parameter or command is incorrect.

To check the reply command, set reply command 31 and 32 to "CHECK".

■ Setting PJLink

The MSD supports PJLink, which is a standard protocol to control projectors.

To use PJLink, select the LAN connector for "COM port" so that you can select PJLink command when entering the send command data.

【See: 9.13.2 LAN operation mode】

[Table 9.25] PJLink command (class1)

No.	Command										Description
1	%	1	P	O	W	R	(SP)	0	(CR)		Power off (Standby)
2	%	1	P	O	W	R	(SP)	1	(CR)		Power on (Lamp on)
3	%	1	P	O	W	R	(SP)	?	(CR)		Get power status
4	%	1	I	N	P	T	(SP)	1	*	(CR)	Switch input to RGB
5	%	1	I	N	P	T	(SP)	2	*	(CR)	Switch input to VIDEO
6	%	1	I	N	P	T	(SP)	3	*	(CR)	Switch input to DIGITAL
7	%	1	I	N	P	T	(SP)	4	*	(CR)	Switch input to STORAGE
8	%	1	I	N	P	T	(SP)	5	*	(CR)	Switch input to NETWORK
9	%	1	I	N	P	T	(SP)	?	CR		Get input selection settings
10	%	1	A	V	M	T	(SP)	1	0	(CR)	Switch off video mute
11	%	1	A	V	M	T	(SP)	1	1	(CR)	Switch on video mute
12	%	1	A	V	M	T	(SP)	2	0	(CR)	Switch off audio mute
13	%	1	A	V	M	T	(SP)	2	1	(CR)	Switch on audio mute
14	%	1	A	V	M	T	(SP)	3	0	(CR)	Video+audio mute off
15	%	1	A	V	M	T	(SP)	3	1	(CR)	Video+audio mute on
16	%	1	A	V	M	T	(SP)	?	(CR)		Get mute settings
17	%	1	E	R	S	T	(SP)	?	(CR)		Get error status
18	%	1	L	A	M	P	(SP)	?	(CR)		Get time and status of lamp
19	%	1	I	N	S	T	(SP)	?	(CR)		Get list of switching input
20	%	1	N	A	M	E	(SP)	?	(CR)		Get projector name
21	%	1	I	N	F	1	(SP)	?	(CR)		Get manufacture name
22	%	1	I	N	F	2	(SP)	?	(CR)		Get product name
23	%	1	I	N	F	O	(SP)	?	(CR)		Get other information (optional of manufacturer)

(SP): space, (CR): delimiter

* You can specify the input number from 1 to 9, but types and the number of selectable input connectors differ depending on the projector. "1" is displayed by default.

Reply command structure for PJLink commands:

The first 6 bites: the sent command data without change; the 7th bite: "=", after the 8th bite: processing result
For example, if a command, "%1POWR 1CR", is processed normally, the reply command, "%1POWR=OK CR" will be replied.

PJLink specifications regulate that projectors are required to reply the reply commands within two seconds after receiving the PJLink command. However, some projectors have different specifications. Check the manual of your projector and apply the response time indicated in the manual if there is one listed.

[Table 9.26] Reply commands to PJLink command (class1)

No.	Command										Description	
1	%	1	x	x	x	x	=	O	K	(CR)	Terminated normally	
2	%	1	x	x	x	x	=	E	R	R	1 (CR)	Mistake in command itself (Undefined command)
3	%	1	x	x	x	x	=	E	R	R	2 (CR)	Invalid parameter
4	%	1	x	x	x	x	=	E	R	R	3 (CR)	Currently not acceptable
5	%	1	x	x	x	x	=	E	R	R	4 (CR)	Malfunction of projector

9.14.2 Registering/Editing reply command

Menu	Top→PRESET COMMAND→RECV COMMAND EDIT
Setting for	Each command
Setting value	[Table 9.28] Setting reply command

You can register and edit up to 32 reply commands.
Press the MENU/SET key to apply the setting.

[Table 9.28] Setting reply command

Item	Description	Range
SIZE	Set the number of bytes from the first byte to be compared.	0 to 30 bytes [Default] 0 byte
PROCESS	Select "STOP" (to stop the next operation), "EXEC" (to execute it), or "RETRY" (to send the command again) for when received data and reply command data match.	EXEC [Default] RETRY: Resend commands STOP
PJLink	Select whether PJLink commands are set or not for when input reply command data is input.	OFF [Default] ON
COMMAND INPUT MODE	Select the input mode of reply command data. "ASCII": For data consisting of only 0A, 0D, 20 to 7D (text) "HEX": For data including other codes	ASCII [Default] HEX
DATA	Set the command to be compared with the received data from the first byte to the byte count set in "SIZE". If using alphabets (A to Z, a to z), make sure to distinguish capital and lower case letters. (Up to 30 bytes)	0A, 0D, and 20 to 7D of ASCII code or 00 to FF (Hex) [Default] 20 (Space)
MASK	Each bit of the received data is ANDed to each bit of mask data, and the result will be compared with the reply command data. (Use this item to determine the state using the received data bit. Settable if "COMMAND INPUT MODE" is set to "HEX"; if "ASCII" is selected, "FF" is set automatically.)	00 to FF (Hex) [Default] All: "FF"
MEMO	Register a note containing up to 14 characters. When reply command is received, the registered note is displayed.	20 to 7D of ASCII code except for 2C (,) [Default] All: Space

Default values in the table above do not apply to reply commands 31 and 32.

■ Setting loop back function

If the MSD sends a communication command back to the MSD itself using the loop back function, the MSD replies “OK” if processed normally while it replies “NG” if parameter or command is incorrect. (This differs from reply commands to communication commands received externally; not loop back.) Since “OK” and “NG” are registered to reply commands 31 and 32 by factory default, respectively, do not edit or delete those commands if you use the loop back function and are checking reply commands.

[Table 9.29] Default value of reply command

Number	SIZE	PROCESS	DATA	MASK	MEMO
1	0 byte	EXEC	All: 00	All: FF	All: 20 (space)
2	0 byte	EXEC	All: 00	All: FF	All: 20 (space)
:	:	:	:	:	:
30	0 byte	EXEC	All: 00	All: FF	All: 20 (space)
31	2 bytes	EXEC	OK	All: FF	OK
32	2 bytes	STOP	NG	All: FF	NG

■ Setting PJLink

For setting PJLink, see “**Setting PJLink**”.

■ Mask data

Each bit of the received data is ANDed to each bit of mask data, and the result will be compared with the reply command data. Since “FF” is set by factory default, you do not need to change the mask data normally. This feature is used to interpret the status of specific bits in received data and provides a reply that can be used to confirm or alter settings.

[If ASCII codes (text) are replied from an external device]

Since the received data and “Reply command data” are compared without any changes, set “MASK” to “FF”. (If you set “COMMAND INPUT MODE” of reply command to “ASCII”, it is automatically set to “FF”.)

For example, if “0” of ASCII codes (“30” in hex) is replied:

	Binary		Binary	Hexadecimal
(Received data)	00110000	& (MASK)	11111111	=30
(Reply command data)	00110000			=30 matched

```
DATA1:30 00 00 00 00
MASK1:FF FF FF FF FF
```

[If status is determined using bits of the received data]

Set only bits that determine the Mask data to “1” and set other bits to “0”.

For example, if determining status using the second bit from the left:

	Binary		Binary	Hexadecimal
(Received data)	11111111	& (MASK)	01000000	=40
(Reply command data)	01000000			=40 matched

	Binary		Binary	Hexadecimal
(Received data)	10111111	& (MASK)	01000000	=00
(Reply command data)	01000000			=40 not matched

```
DATA1:40 00 00 00 00
MASK1:40 FF FF FF FF
```

9.14.3 Command link

Menu	Top→PRESET COMMAND→COMMAND LINK
Setting for	[Table 9.30] Control command execution condition
Setting value	OFF [Default], COMMAND 1 to COMMAND 32

The MSD has 180 command execution conditions as shown below. If these execution conditions are met, control commands which are associated beforehand will be executed. One execution condition can be associated to up to 10 commands. If multiple commands are associated, commands are executed in order of registration. If the same command is associated multiple times, it is repeatedly executed.

Control command execution button can be toggled.

Set "TOGGLE" to "ON" to enable PLANE-B, and then you can select execution plane ("AUTO", "A(PLANE-A)", or "B(PLANE-B)") at the time of power ON from "STARTUP". If you select "AUTO", the condition at the time of power OFF will be maintained.

Press the MENU/SET key to apply the setting.

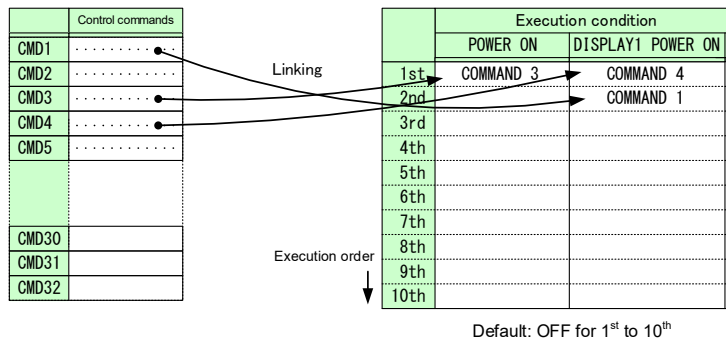

[Fig. 9.28] Command link

[Table 9.30] Control command execution condition (MSD-6204)

Execution condition	Function
POWER ON	Controlling power switch
STANDBY	
COMMAND A to COMMAND I, PLANE-A	Control command execution key
COMMAND A to COMMAND I, PLANE-B	
DISPLAY1 POWER ON	Controlling sink device power of OUT1
DISPLAY1 POWER OFF	
VIDEO:OUT1-IN1 to VIDEO:OUT1-IN8, VIDEO:OUT1-OFF	Selecting video input channel of OUT1
AUDIO:OUT1-IN1 to AUDIO:OUT1-IN8, AUDIO:OUT1-OFF	Selecting audio input channel of OUT1
DISPLAY2 POWER ON	Controlling sink device power of OUT2
DISPLAY2 POWER OFF	
VIDEO:OUT2-IN1 to VIDEO:OUT2-IN8, VIDEO:OUT2-OFF	Selecting video input channel of OUT2
AUDIO:OUT2-IN1 to AUDIO:OUT2-IN8, AUDIO:OUT2-OFF	Selecting audio input channel of OUT2
DISPLAY3 POWER ON	Controlling sink device power of OUT3
DISPLAY3 POWER OFF	
VIDEO:OUT3-IN1 to VIDEO:OUT3-IN8, VIDEO:OUT3-OFF	Selecting video input channel of OUT3
AUDIO:OUT3-IN1 to AUDIO:OUT3-IN8, AUDIO:OUT3-OFF	Selecting audio input channel of OUT3
DISPLAY4 POWER ON	Controlling sink device power of OUT4
DISPLAY4 POWER OFF	
VIDEO:OUT4-IN1 to VIDEO:OUT4-IN8, VIDEO:OUT4-OFF	Selecting video input channel of OUT4
AUDIO:OUT4-IN1 to AUDIO:OUT4-IN8, AUDIO:OUT4-OFF	Selecting audio input channel of OUT4

9.14.4 Command execution

Menu	Top→PRESET COMMAND→COMMAND EXECUTION
Setting value	CMD 1 to CMD 32, COMMAND A to COMMAND I

You can execute registered control commands.
 Executable control commands are displayed.
 Press the MENU/SET key to apply the setting.

【See: 9.14.1 Registering/editing control command】

9.14.5 Invalid duration at control command execution

Menu	Top→PRESET COMMAND→INVALID TIME
Setting value	0s000ms to 999s999ms [Default] 0s000ms

You can set the wait time that starts at control command execution and must elapse prior to accepting user input to resend the command. Use this menu to prevent repeated execution caused by pressing the control command execution key twice.

The longer time either of control command execution time or the time set in this menu will be applied as the invalid operation time. Only operations from ports that execute control commands will be invalid; operations from other ports can be performed.

For example, if you execute a command from a command execution key, you cannot perform any operations from command execution keys until the control command is completed. However, for DISPLAY POWER keys and CHANNEL SELECTION keys, even during the invalid duration, control command from different outputs can be executed.

9.14.6 Initializing registered command and link

Menu	Top→PRESET COMMAND→INITIALIZE
Setting value	CMD 1 to CMD 32 : Control command RCV 1 to RCV 32 : Reply command POWER ON : Control command association

You can initialize the following commands and associations:

- Control commands registered in “**9.14.1 Registering/editing control command**”
- Reply commands registered in “**9.14.2 Registering/Editing reply command**”
- Control command link “**9.14.3 Command link**”

Use this menu to delete or set them from the first step again.

You will hear a beep tone when the initialization is completed by pressing the MENU/SET key.

9.14.7 Command execution key: Illuminating condition

Menu	Top→PRESET COMMAND→COMMAND TALLY
Setting for	Each control command execution key
Setting value	REGISTERED : Illuminates if a control command is registered *1 [Default] EXECUTION : Illuminates while a control command is executed *1*2

If you set “LINK” to “ON”, you can change all lighting conditions at once.

*1 There are two planes (PLANE A and B) for each execution condition of COMMANDs A to I. If you register control commands for both planes, the control commands are executed alternatively every time you press the command key as follows.

*2 If execution duration is 500 ms or shorter, the key illuminates for 500 ms. It also blinks by changing the setting of “9.14.8 Blinking at command execution key”.

[Table 9.31] Illuminating condition

Illuminating condition	If you register a command only for one plane	If you register commands for both two planes
REGISTERED	Illuminates if a control command is registered	Illuminates if PLANE A will be executed at the next press; blinks if PLANE B will be executed at the next press.
EXECUTION	Illuminates while a control command is being executed	Illuminates if PLANE A will be executed at the next press; turned off if PLANE B will be executed at the next press.

9.14.8 Blinking at command execution key

Menu	Top→PRESET COMMAND→FLASH TIME
Setting for	Each control command execution key, each DISPLAY POWER key
Setting value	EXECUTION : Blinks while a control command is being executed [Default] (DISPLAY POWER key) OFF : Not blink [Default] (Control command execution key) 1sec. to 1000sec.: Blinks for the specified time (1 to 1000 sec.)

You can set the blinking duration of command execution keys and DISPLAY POWER key during command execution.

While control commands are being executed, these keys blink regardless of this menu’s setting.

9.15 Preset memory

You can set the crosspoint memory and preset memory.

9.15.1 Recalling crosspoint

Menu	Top→PRESET MEMORY→LOAD CROSS POINT
Setting value	No.1 to No.9

You can recall the I/O channel settings saved in the crosspoint memory. You can also recall settings by pressing control command execution keys (COMMAND A to COMMAND I).

Press the MENU/SET key to apply the setting.

【See: 9.15.2 Saving crosspoint】

9.15.2 Saving crosspoint

Menu	Top→PRESET MEMORY→SAVE CROSS POINT
Setting for	NONE
Setting value	No.1 to No.9

You can save the I/O channel settings of video and audio into the crosspoint memory.

Up to 9 crosspoint memories can be saved with their name (up to 10 characters). If you set “---” (not control) for “**9.15.3 Editing crosspoint**”, a writing method (CONTINUE or DELETE) can be selected.

Press the MENU/SET key to apply the setting.

■ For writing

“CONTINUE”: The setting (“---”) will be kept in the crosspoint memory.

“DELETE” : The current input channel settings will be overwritten.

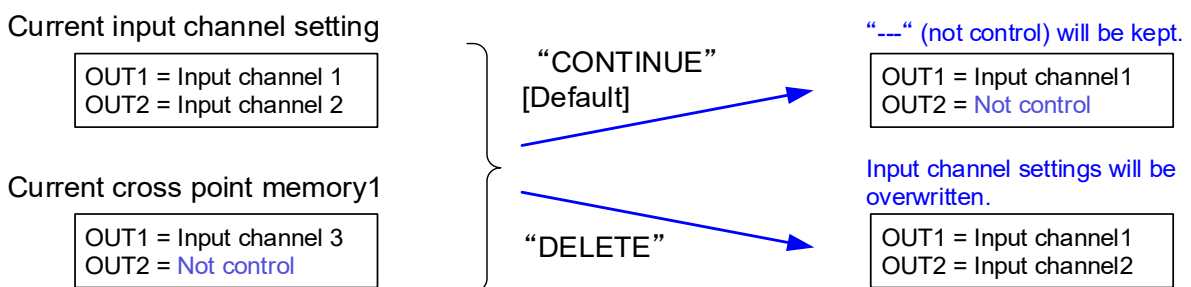

【Fig. 9.29】 Saving crosspoint

9.15.3 Editing crosspoint

Menu	Top→PRESET MEMORY→EDIT CROSS POINT
Setting for	Each crosspoint memory
Setting value	[Table 9.32] Editing crosspoint

[Table 9.32] Editing crosspoint

Setting item	Setting value	Default
Output channel (OUT)	1 to 4	-*
Video input channel (V)	--- (Not control), 1 to 8, OFF	---
Audio input channel (A)	--- (Not control), 1 to 8, OFF	---
Memory name (NAME)	20 to 7D of ASCII code	20 (space)

*Setting input channels of video and audio for each output channel

You can edit crosspoint memory settings.

First, select the memory number and press the MENU/SET key, and then edit the desired setting. Press the MENU/SET key to apply the setting.

■ Not controlling channel

If you select "---" when setting input channel of V or A, channels are not controlled.

Outputs that are set not to be controlled are not switched when crosspoint memory is loaded.

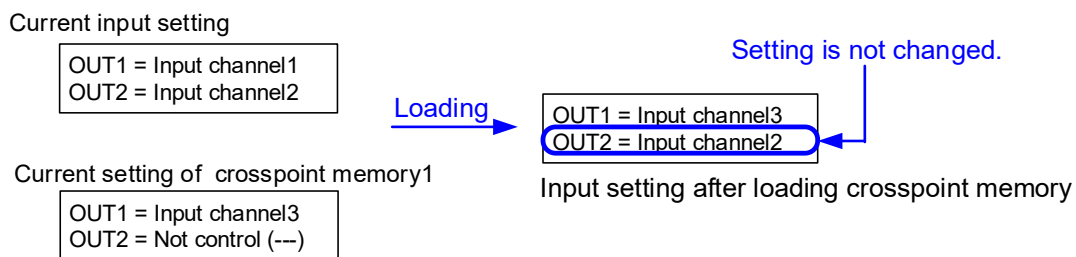

[Fig. 9.30] Loading edited crosspoint memory

9.15.4 Recalling all settings

Menu	Top→PRESET MEMORY→LOAD ALL SETTING
Setting value	No.1 to No.12

You can recall all settings saved in the preset memory.

Once you perform this operation, all settings related to video and audio I/O except for some environmental settings will be updated. Operate this feature with great care.

This menu is not displayed if settings are not saved in memory.

Setting examples of video combination mode are stored in No.10 to No.12 by default. Settings of normal mode are stored in No.9.

Press the MENU/SET key to apply the setting.

9.15.5 Saving all settings

Menu Top→PRESET MEMORY→SAVE ALL SETTING

Setting value No.1 to No.12

You can save up to 12 preset memories and name these memories up to 10 characters from ASCII 20 to 7D. You can skip the naming procedure.

Press the MENU/SET key to apply the setting.

[Table 9.33] Settings saved in preset memory

Menu	Description
Selecting input channels	Selecting input channels
Setting position, size, and masking	Output resolution, Aspect ratio for sink device, Aspect ratio, Aspect ratio control, Overscan, Display position, Display size, Masking, Background color, Test pattern
Video processing mode	Video output mode, Window setting, Horizontal flip, Window hiding
Quality setting	Sharpness, Brightness, Contrast, HUE, Saturation, Black level, Gamma
Input settings	No-signal input monitoring, HDCP input setting, Analog input signal parameters, Automatic detection of video input interruption, Selecting signal of DVI input connector, HDBaseT input long reach mode
Setting input timing	The total number of horizontal dots, Start position, Active area, Automatic measurement of start position, Automatic setting of input timing, Tracking
Output settings	Output equalizer, Output mode, Synchronous signal output with no input video, Output video with no input video, Window transition effect, Window transition speed, Wipe color, Output connector, HDCP output, The number of HDCP , Deep Color, CEC, Priority of input channel automatic switching, Ignoring duration after automatic switching, Channel switching mode of automatic switching, HDBaseT output long reach mode
Audio setting	Output level, Output mute, Selecting audio input, Audio input level, Lip sync, Sampling frequency, Analog audio output connector, Multi-channel audio output, Test tone
EDID	EDID, Resolutions for PCs, Input resolution for AV devices, Deep Color, Audio format, Speaker configuration
Setting DANTE (Optional) *	CH61-CH64

*Displayed only if Dante (optional) is installed.

9.15.6 Copying output setting

Menu	Top→PRESET MEMORY→COPY OUTPUT MEMORY
Setting value	OUT1 to OUT4 → OUT1 to OUT4

You can copy the setting of the selected output channel to other output channels.
Press the MENU/SET key to apply the setting.

[Table 9.34] Setting to be copied

Menu	Description
Selecting input channels	Selecting input channels
Setting position, size, and masking	Output resolution, Aspect ratio for sink device, Aspect ratio, Aspect ratio control, Overscan, Display position, Display size, Masking, Background color, Test pattern
Video processing mode	Horizontal flip
Quality setting	Brightness, Contrast, Gamma
Output settings	Output equalizer, Output mode, Synchronous signal output with no input video, Output video with no input video, Window transition effect, Window transition speed, Wipe color, Output connector, HDCP output, The number of HDCP, Deep Color, CEC, Priority of input channel automatic switching, Ignoring duration after automatic switching, Channel switching mode of automatic switching, HDBaseT output long reach mode
Audio setting	Output level, Output mute, Lip sync, Sampling frequency, Analog audio output connector, Multi-channel audio output, Test tone
Bitmap setting	Outputting bitmap image, Background color, Aspect ratio, Display position, Assigning input channel, Startup bitmap output

Note:

Only one CEC connection is available; multiple input and outputs cannot be connected simultaneously. For example, CEC connection is copied from this menu, the lowest output (OUT1) is connected preferentially and the sink device connected to OUT2 cannot output video with CEC.

9.15.7 Start-up setting

Menu Top→PRESET MEMORY→STARTUP

Setting value [Table 9.35] Start-up setting

You can configure which settings will be applied at start-up.

[Table 9.35] Start-up setting

Item	Setting value	Startup operation
Last channel	LAST CHANNEL [Default]	Starts with the settings last time the MSD powered off.
Preset memory	PRESET MEMORY 1 to PRESET MEMORY 12*	Starts with the settings saved in the preset memory. For settings that are not saved in the preset memory, settings last time the MSD powered off will be applied.
Crosspoint memory	CROSS POINT 1 to CROSS POINT 9	Starts with the channel settings saved in the selected crosspoint memory. For settings other than channel settings, settings last time the MSD powered off will be applied.
Channel OFF	CHANNEL OFF	Turns channel OFF. For settings other than channel setting, settings last time the MSD powered off will be applied.

*Only registered preset memory numbers are displayed.

9.16 Bitmap setting

9.16.1 Sending bitmap file

You can set the bitmap image to be displayed on the sink device. Up to four bit maps can be registered.

IDK's logo is displayed by default.

Bitmaps can be enlarged but cannot be reduced. The larger the resolution is, the longer the output time will be, and it may take a maximum of approximately six seconds to output a bitmap. Register a bitmap having smaller resolution than that of the sink device.

■ Conditions of bitmap file

The MSD supports DIB (Device Independent Bitmap) with a header generally used for Windows, and those files must meet the following requirements:

[Table 9.36] Bitmap file condition

Item	Condition
File header	"BITMAPFILEHEADER"
Information header	"BITMAPCOREHEADER" (for OS/2)/ "BITMAPINFOHEADER" (for Windows)
The number of colors	2 colors (monochrome, 1 bit), 16 colors (4 bits), 256 colors (8 bits), 16.77 million colors (TRUE COLOR, 24 bits)
Resolution	The maximum resolution: [Horizontal resolution x Vertical resolution x The number of bytes per pixel] = 8,388,608 bytes or less. If you register multiple bitmaps, the total bytes of all bitmaps should be 8,388,608 bytes or less. (Aspect ratio does not matter as long as it is within the maximum resolution). Bytes per pixel: 1 byte per pixel for 2 colors (monochrome, 1 bit), 16 colors (4 bits), and 256 colors (8 bits); 3 bytes per pixel for 16.77 million colors (TRUE COLOR, 24 bits).
Compression format	No compression (BI_RGB), 8 bit-run-length compression (BI_RLE8), 4 bit-run-length compression (BI_RLE4)

■ Transferring bitmap file

Use a browser (e.g. Microsoft Internet Explorer) to transfer bitmap files to the MSD.

Enter "/bitmap.html" after the IP address that is programmed to the MSD.

【See: 9.13.1 IP address/Subnet mask/Gateway address】

【See: 9.13.3 TCP port number】

[Table 9.37] Address input example

Control port number of web browser	IP address (URL)
80 (Normal)	http://192.168.1.199/bitmap.html
Other than 80 (5000 to 5999)	http://192.168.1.199:5000/bitmap.html (e.g.: 5000)

Enter the URL to display the following page.

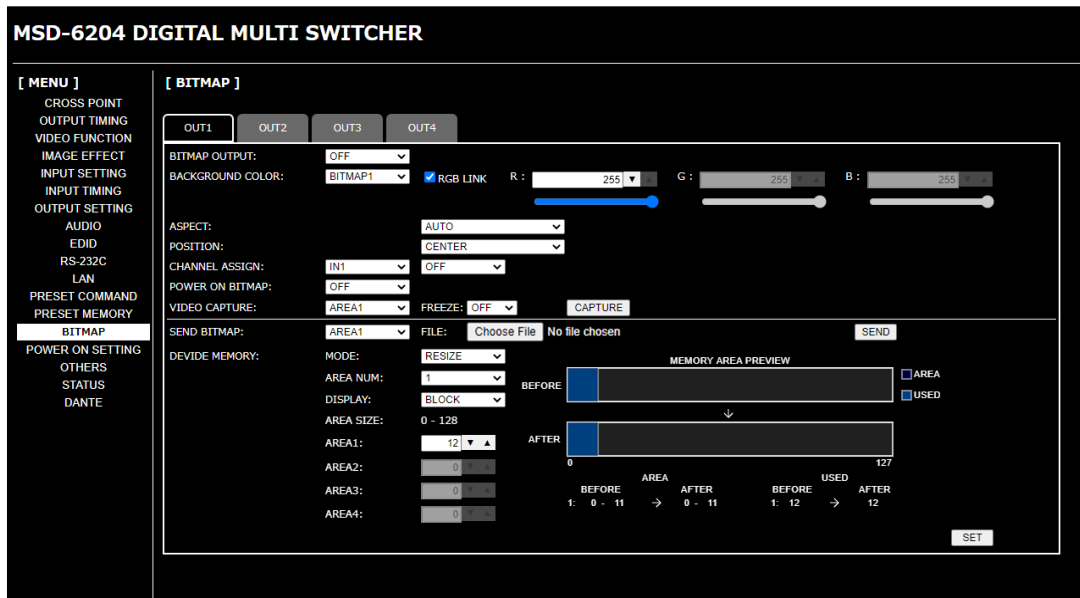

[Fig. 9.31] Bitmap setting page (Example: MSD-6204 with Dante)

Once bitmap file is transferred correctly, the message, “BITMAP SAVE NOW PLEASE WAIT”, is displayed. Do not power off the MSD while the message is displayed. In case the bit map file is not correct, an error message will be displayed.

[Table 9.38] Bitmap transfer error message

Message	Description
FILE NAME INVALID	The specified file name is not correct.
FILE DATA INVALID	The MSD does not support this file.
FILE DATA SIZE OVER	The file exceeds the maximum resolution.
MEMORY ALLOCATE ERROR	The memory for temporarily saving bitmap file could not be reserved. The error may possibly be solved by rebooting the MSD and sending the bitmap file again.
—	Send the bitmap data sequentially. If the data transmission is disconnected for two seconds or longer, an error occurs.

9.16.2 Outputting bitmap image

Menu	Top→BITMAP→BITMAP OUTPUT
Setting for	Each output channel
Setting value	OFF [Default] ON (BITMAP1 ON to BITMAP4 ON)

You can enable/disable the bitmap image output.

If multiple bitmaps are registered, select the bitmap number you want to output.

9.16.3 Background color

Menu	Top→BITMAP→BACKGROUND COLOR
Setting for	Each output channel, each bitmap
Setting value	R/G/B: 0 to 255 [Default] R/G/B: 255 (white)

You can set the background color of the bitmap.

If you set "LINK" to "ON", you can set only Red (R). Settings for Green (G) and Blue (B) will track the setting value selected for Red (R).

If more than one bitmap is registered to the MSD, you can confirm the bitmap number at left of the second line on the front VFD screen.

9.16.4 Aspect ratio

Menu	Top→BITMAP→ASPECT
Setting for	Each output channel, each bitmap
Setting value	[Fig. 9.32] Setting aspect ratio

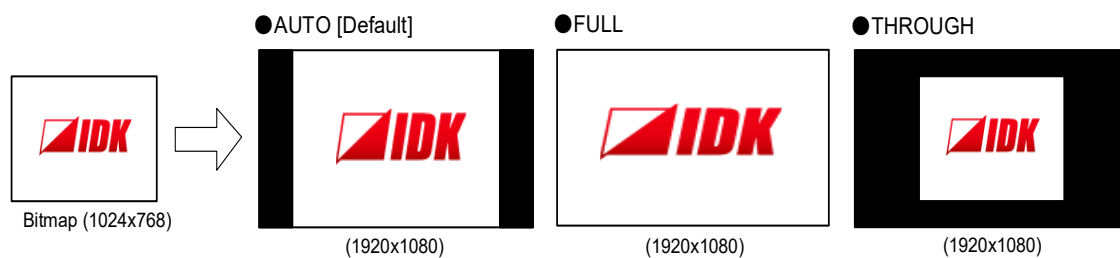

[Fig. 9.32] Setting aspect ratio

You can set the aspect ratio of bitmap.

If you select "AUTO", the aspect ratio is kept. However, if bitmap is larger than output resolution, only a portion of the bitmap is displayed.

9.16.5 Display position

Menu	Top→BITMAP→POSITION
Setting for	Each output channel, each bitmap
Setting value	[Fig. 9.33] Position

You can set the display position of the bitmap.

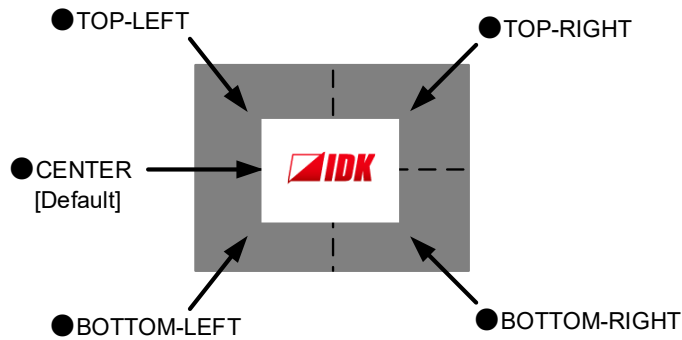

[Fig. 9.33] Position

9.16.6 Assigning input channel

Menu	Top→BITMAP→CHANNEL ASSIGN
Setting for	Each input channel, each output channel
Setting value	OFF [Default], ON (BITMAP1 ON to BITMAP4 ON)

A bitmap can be treated as an input video source by assigning the bitmap to any input that is not currently being used. Set “**9.16.2 Outputting bitmap image**” to “OFF” in order to assign the bitmap to an input channel.

If multiple bitmaps are registered, select the bitmap number to be output.

If you switch an input to a bitmap image, it takes longer than a switching transition between normal channels. In other words, it will take longer to display an output image and you cannot perform other operations until the bitmap is displayed.

Press the MENU/SET key to apply the setting.

9.16.7 Startup bitmap output

Menu	Top→BITMAP→POWER ON BITMAP
Setting for	Each output channel
Setting value	OFF [Default], ON (BITMAP1 ON to BITMAP4 ON)

You can enable/disable presenting a bitmap output at startup.

9.16.8 Dividing memory area

Menu Top→BITMAP→DIVIDE MEMORY

Setting value [Table 9.39] Dividing memory area

You can register up to four bitmaps within the available memory area by dividing the memory. You can select one of three dividing modes or specify the size you want to divide manually.

Memory areas are controlled by blocks. 1 block = 64K bytes; 128 blocks = 8M bytes in total

Press the MENU/SET key to apply the setting.

[Table 9.39] Dividing memory area

Setting item	Setting value	Default
MODE (dividing mode)	RESIZE,DELETE,AUTO	RESIZE
NUMBER (the number of partitions)	1 to 4	1
DISPLAY (displaying method)	BLOCK,BYTE	BLOCK
End block position	0 to 127	127

■ Dividing mode

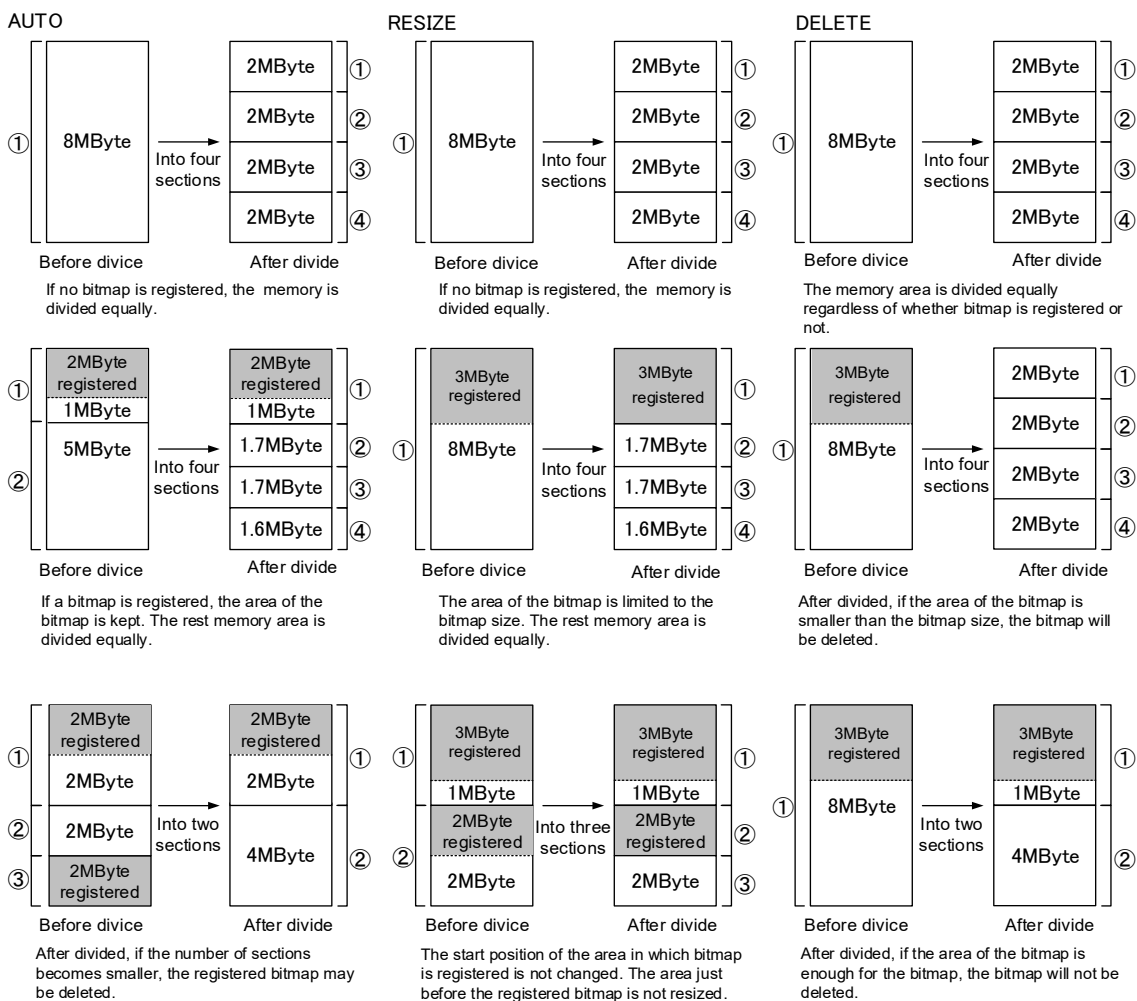

[Fig. 9.34] Dividing mode

■ Displaying method

“BLOCK”

If you select “BLOCK” for “DISPLAY”, the current start and end block positions are displayed on the left of the VFD screen. If a bitmap is registered, the final block position is displayed in parentheses. The start and end block positions after divide are displayed on the right. If you want to specify the after-divide size directly, change the end block position.

If the currently-registered bitmap is deleted because of specifying the size directly, an “S” or “E” is displayed in the upper right.

“BYTE”

The currently-reserved memory size is displayed on the left. If a bitmap is registered, the number of bytes is displayed in parentheses. The memory size after dividing is displayed on the right so that you can specify directly the after-division memory size.

If the currently-registered bitmap is deleted because of specifying the size directly, an “S” or “E” is displayed in the upper right.

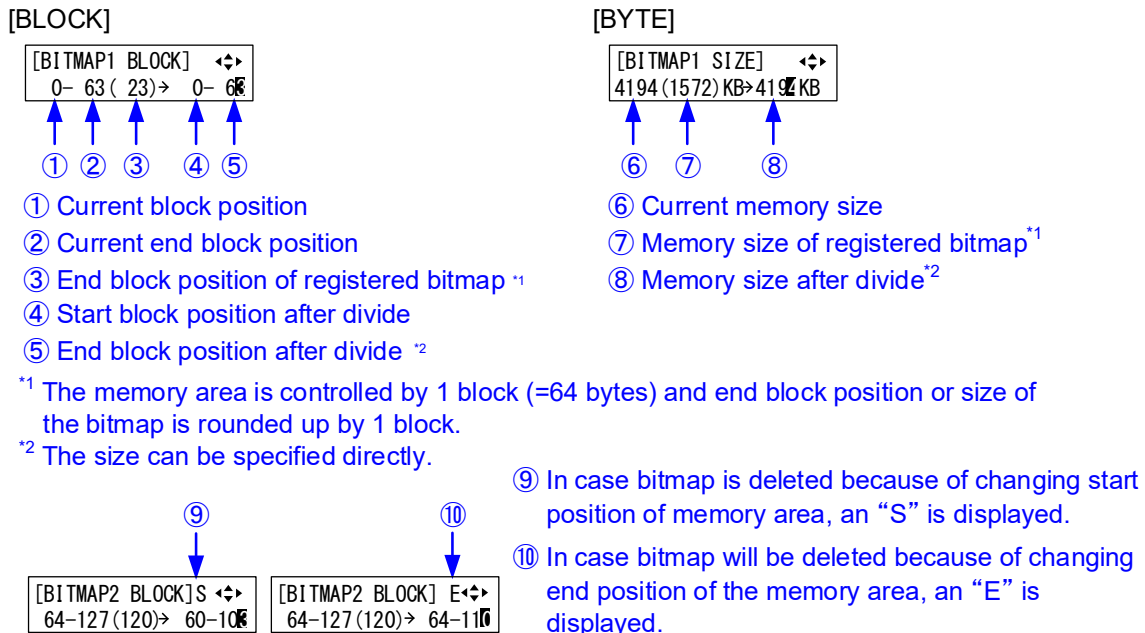

[Fig. 9.35] “BLOCK” and “BYTE”

9.16.9 Input image capture

Menu Top→BITMAP→VIDEO CAPTURE
 Setting value [Table 9.40] Setting input image capture

[Table 9.40] Setting input image capture

Setting item	Setting value	Default
Output channel	OUT1, OUT2, OUT3, OUT4	OUT1
Register number	No.1 to No.4*	No.1

*Can be set if memory area is divided.

An input video can be treated as a bitmap by capturing and registering it. The maximum resolution is [Horizontal resolution x Vertical resolution x 3 (the number of bytes per pixel; "3" fixed)] 8,388,608 bytes or less. To register multiple bitmaps and captured images, the total resolution of all bitmaps and captured images should be 8,388,608 bytes or less (aspect ratio does not matter).

Captured images can be displayed at native size or may be enlarged, but cannot be reduced in size. Larger resolutions require a longer loading time; it may take approximately six seconds at a maximum. Registered images having a lower resolution than the target sink device.

If an input image is larger than the output resolution, capture it with a reduced image size. If an input image is the same size or smaller, capture it without changing its size. You can register any images having a lower resolution by setting "**9.4.1 Output resolution**" to smaller resolution and capturing the video.

To freeze the input video temporarily, press the "MENU/SET" key. To register the frozen image, select "YES" and then press the "MENU/SET" key again. To release freeze, press the "ESC" key. It can be released automatically when an input channel is switched or input signal changes.

If resolution of input video is too large compared to the reserved memory area, it can cause a significant memory shortage. In this case, message "MEMORY SIZE OVER" will be displayed after you press the "MENU/SET" key and registration will not be executed.

■ From browser

You can capture and save an input video through a WEB browser as well.

Step1) If the memory area is divided, select the registered area of the captured image.

Step2) Set “FREEZE” to “ON”. You can skip this step. This freeze is only temporary. If input channel is switched or input signal changes, the freeze is released and the input video will be output.

Step3) Click the “CAPTURE” button to display the dialog box. Click the “OK” button of the dialog box to capture the video. If you skip the Step2, the video freezes automatically just after clicking the “OK” button.

【See: 8.10 Control from WEB browser】

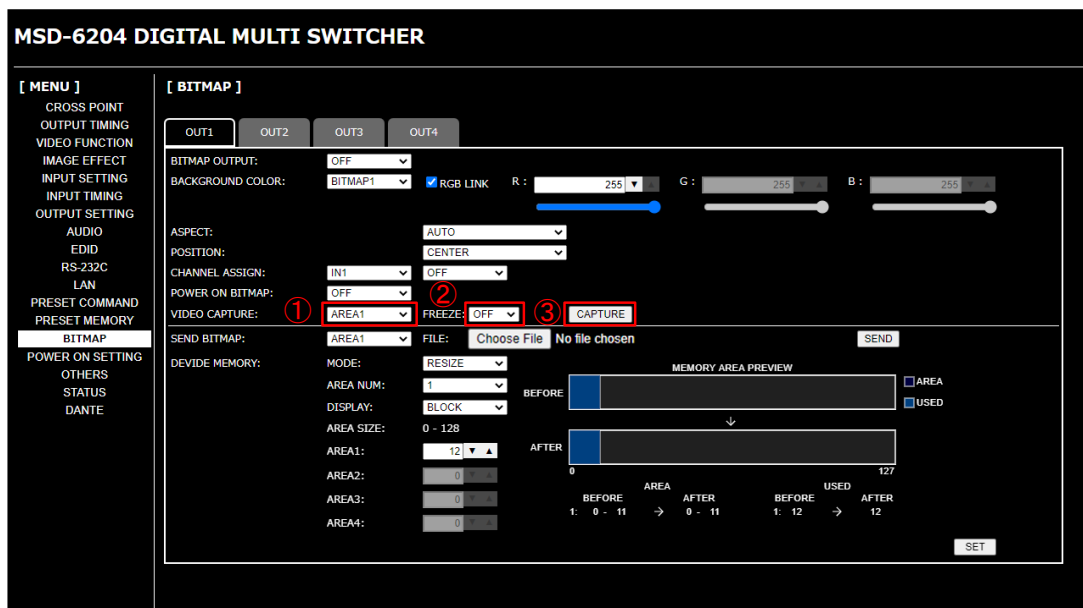

- ① Select the registered area of the captured video (for memory area division).
- ② Select the freeze of input video. (You can skip this step)
- ③ Start the capture by clicking the “CAPTURE” button.

【Fig. 9.36】 Capturing input image (Example: MSD-6204 with Dante)

When capture completes correctly, the message is displayed. Click the “OK” button of the dialog box to complete.

Do not operate the WEB menu or turn off the MSD until the registration completes.

If capture does not start correctly or failed, an error message below will be displayed.

【Table 9.41】 Error message

Message	Description
Video Capture is not available because there is no input signal.	Capture fails because input image is not displayed.
Memory Size Error is happened.	Data cannot be saved because the input image size is larger than the allocated memory area.

9.17 Startup setting

9.17.1 Power state

Menu Top→POWER ON SETTING→POWER SWITCH

Setting value AUTO [Default], OFF, ON

You can set the MSD's standby state for when the rear panel main POWER switch is turned on.

【See: 8.1 Main power switch and standby key】

[Table 9.42] Standby switch state for when main POWER switch is turned on

Condition		Status
Setting value	Power state before main POWER switch is powered off	Power state after main POWER switch is powered on
AUTO	Standby	Standby
	Powered on	Powered on
OFF	Standby	Standby
	Powered on	
ON	Standby	Powered on
	Powered on	

Note:

“[Table 9.42]” is also applied when the power state is changed by the external power supplier.

9.17.2 DISPLAY POWER keys

Menu	Top→POWER ON SETTING→DISPLAY POWER
Setting for	Each output channel
Setting value	AUTO [Default], OFF, ON

You can set the DISPLAY POWER key state for when MSD is powered on.

“AUTO” : The same state as it was before powering off the MSD or entering standby mode.

“OFF” : DISPLAY POWER keys do not operate.

“ON” : Commands are executed if commands are registered in a DISPLAY POWER key.

【See: 9.14.3 Command link】

[Table 9.43] Startup sink device power state

	Condition	State
Setting value	DISPLAY POWER key state before the MSD is powered off or going into standby.	DISPLAY POWER key state after the MSD is powered on.
AUTO	OFF	OFF
	ON	ON
OFF	OFF	OFF
	ON	
ON	OFF	ON
	ON	

9.17.3 Control command execution key

Menu Top→POWER ON SETTING→COMMAND/PRESET
 Setting value AUTO [Default], COMMAND, PRESET LOAD, LOCK

You can set the control command execution key state for when MSD is powered on.

“AUTO” : The same state as it was before powering off the MSD.

“COMMAND” : Control command can be executed.

“PRESET LOAD” : Preset memory can be executed.

“LOCK” : Control command execution keys are locked.

[Table 9.44] Control command execution key state for when MSD is powered on

	Condition	State
Setting value	Control command execution key state before the MSD is powered off or goes into standby.	Control command execution key state after the MSD is powered on.
AUTO	COMMAND	COMMAND
	PRESET LOAD	PRESET LOAD
	LOCK	LOCK
COMMAND	COMMAND	COMMAND
	PRESET LOAD	
	LOCK	
PRESET LOAD	COMMAND	PRESET LOAD
	PRESET LOAD	
	LOCK	
LOCK	COMMAND	LOCK
	PRESET LOAD	
	LOCK	

9.17.4 Key function lock

Menu Top→POWER ON SETTING→OPERATION LOCK
 Setting value AUTO [Default], UNLOCK, LOCK

You can set the key function lock for when the MSD is powered on.

“AUTO” : The same state as it was before powering off the MSD.

“UNLOCK” : Key function is unlocked.

“LOCK” : Key function is locked.

【See: 9.18.1 Grouping key function lock】

[Table 9.45] Start-up key function lock

	Condition	State
Setting value	Lock state before the MSD is powered off or entered standby.	Lock state after the MSD is powered on.
AUTO	UNLOCK	UNLOCK
	LOCK	LOCK
UNLOCK	UNLOCK	UNLOCK
	LOCK	
LOCK	UNLOCK	LOCK
	LOCK	

9.18 Other settings

9.18.1 Grouping key function lock

Menu	Top→OTHERS→OP LOCK MODE
Setting for	CHANNEL, MENU, PRESET LOAD, COMMAND, DISPLAY POW
Setting value	LOCK [Default], UNLOCK

You can group front keys for key function lock.

【See: 8.7 Locking and unlocking key function】

【See: 8.2 Selecting input channels】

[Table 9.46] Grouping front keys

For	Target keys
CHANNEL	Input channel selection keys
MENU	Menu operation keys
PRESET LOAD	Locks loading crosspoint Control command execution key (COMMAND A to COMMAND E)
COMMAND	Locks control command execution Control command execution keys (COMMAND A to COMMAND E)
DISPLAY POW	Power key of sink device (DISPLAY POWER)

9.18.2 Beep

Menu	Top→OTHERS→BUZZER
Setting value	ON [Default], OFF

You can enable/disable the beep tone function (sounding every time you press a front panel key).

9.18.3 Automatic lock of control command execution key

Menu	Top→OTHERS→COMMAND AUTO LOCK
Setting value	ON [Default], OFF

If you select “ON” and no key function is operated for 30 seconds, the control command execution key is set to be locked.

9.18.4 Power saving

Menu	Top→OTHERS→POWER SAVE
Setting value	ON [Default], OFF

If you select “ON” and no key function is operated for 30 seconds, the display brightness is reduced to approximately 25%. When you operate any key, brightness returns to 100%.

9.18.5 DISPLAY POWER key pressing duration

Menu	Top→OTHERS→DISP POW BUTTON ON
Setting value	0ms to 5000ms (by 10 ms) Default 0ms

You can set the key press dwelling time of the target DISPLAY POWER key to prevent the sink device from being powered off if the key is pressed accidentally.

9.18.6 HDBaseT input power supply

Menu	Top→OTHERS→HDC POWER OUTPUT
Setting value	ON, OFF [Default]

You can set the power supply function from the HDBaseT input connector.

“ON”: Power will be supplied to an HDBaseT transmitter supporting PoH (IEEE802.3af).

Press the MENU/SET key to apply the setting.

Note:

If you connect a device that does not support PoH (IEEE802.3af) while HDC POWER OUTPUT is enabled, the MSD and the connected device may be damaged.

9.18.7 Input channel automatic linking

Menu	Top→OTHERS→INPUT CHANNEL LINK
Setting value	VIDEO: OFF [Default], OUT1 to OUT4 AUDIO: OFF [Default], OUT1 to OUT4

The menu pages of each input channel can be displayed by selecting the input number of the menus. With this menu, the menu pages of each input channel can be displayed automatically by switching input in “8.2 Selecting input channels”.

This function is convenient to adjust each input channel based on specific display devices or AV amplifiers.

The menu page of the input channel can be displayed separately for video and audio.

[Input channel automatic linking: “OUT 1”]

Video menu page of IN1 is displayed →
Audio menu page of IN4 is displayed →
1 Video menu page of IN3 is displayed →
Audio menu page of IN4 is displayed →
2 Video menu page of IN3 is displayed →
Audio menu page of IN2 is displayed →
3 Video menu page of IN3 is displayed →
Audio menu page of IN2 is displayed

- 1 IN3 is selected for video input channel of OUT1. Video menu pages of IN3 will be displayed automatically.

For example, in the “Input Status” menu, IN3 video information is displayed automatically.

[IN3 FORMAT]	Type0
2160p 59.94Hz	HZ

- 2 IN2 is selected for audio input channel of OUT1. Audio menu pages of IN2 will be displayed automatically.

For example, in the “Input Status” menu, IN2 audio information is displayed automatically.

[IN2 AUDIO]	M↕
LINEAR PCM 48kHz	

- 3 IN5 is selected for audio input channel of OUT2. Audio menu pages are not changed.

[IN2 AUDIO]	M↕
LINEAR PCM 48kHz	

[Fig. 9.37] Input channel automatic linking

[Table 9.47] For video

Menu	Description
Setting position, size, and masking	Aspect ratio, Aspect ratio control, Overscan, Display position, Display size, Masking, Automatic sizing
Quality setting	Sharpness, Brightness, Contrast, HUE, Saturation, Black level, Default color
Input settings	Analog input signal parameters
Setting input timing	Automatic measurement, The total number of horizontal dots, Start position, Active area, Loading device data, Registering device data, Tracking
Other settings	Input signal status

[Table 9.48] For audio

Menu	Description
Audio setting	Audio input level, Lip sync
Other settings	Input signal status

9.18.8 Top page

Menu Top→OTHERS→TOP DISPLAY
 Setting value [Fig. 9.38] Top page of VFD screen

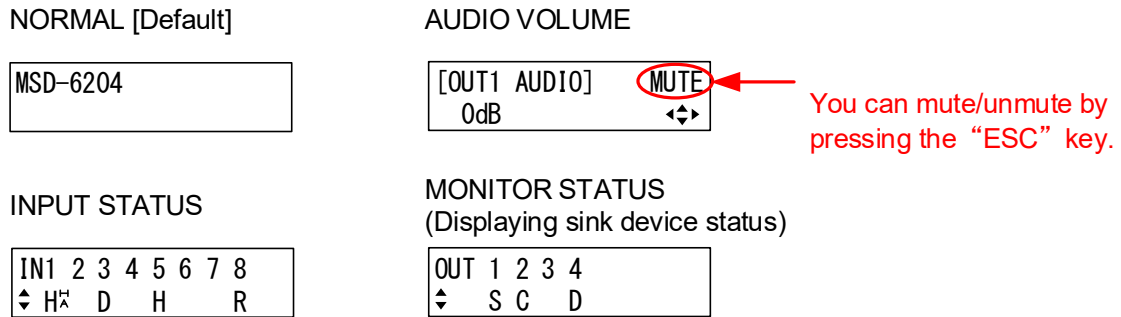

[Fig. 9.38] Top page of VFD screen

For the top page, you can select one of four types above.

With input signal status and sink device status pages, the details of each signal can be displayed using “▲” and “▼” keys.

【See: 9.18.9 Input signal status】

【See: 9.18.10 Sink device status】

9.18.9 Input signal status

Menu Top→OTHERS→INPUT STATUS

Values to be displayed [Table 9.49] Input signal status

You can view the input signal status that is input from HDMI and DVI input connectors.

[Table 9.49] Input signal status

	All input channels	Video status of each input channel	Audio status of each input channel
Display	<div style="border: 1px solid black; padding: 5px; width: fit-content;"> IN1 2 3 4 5 6 7 8 ↕ H[Ⓜ] D H R </div>	<div style="border: 1px solid black; padding: 5px; width: fit-content;"> [IN1 FORMAT] 24 1080p 59.94Hz H[Ⓜ] </div>	<div style="border: 1px solid black; padding: 5px; width: fit-content;"> [IN1 AUDIO] M[Ⓜ] LINEAR PCM 48kHz </div>
Upper	Input channel	Input channel, Deep Color	Input channel, multi-channel audio information
Lower	Input signal type, other information	Video signal format, input signal type, other information	Audio signal type

■ Input signal type

[Table 9.50] Input signal type

Alphabet	Signal	Alphabet	Signal
H	HDMI signal	R	Analog RGB signal
D	DVI signal	Y	Analog YPbPr signal
No alphabet	No signal is input.		

■ Other information

Only for digital input

Upper: "H": signal is protected by HDCP.

Lower: "A": audio is embedded.

■ Deep Color

24: 24-BIT COLOR

30: 30-BIT COLOR

■ Input video signal format

[Table 9.51] Input video signal format

Example	Signal type	Items to be displayed
1080p 59.94Hz	SDTV/HDTV signal	Format type, vertical sync frequency
800 x 600 60.00Hz	RGB signal	Horizontal/vertical resolution, vertical sync frequency
56.83kHz 60.02Hz	Signal that cannot be recognized	Horizontal/vertical sync frequency
NO SIGNAL	No video signal is input.	

If the dot clock of the input signal exceeds the limitation, “E” is displayed on the left of the input signal type, and the video is not output.

[IN1 FORMAT]	24
2160p 30Hz	EH*

■ Multi-channel audio information

If multi-channel audio signal is input, an “M” is displayed on the upper right.

■ Input audio signal type

[Table 9.52] Input audio signal type

Example	Signal type
LINEAR PCM 48kHz	LPCM, sampling frequency
COMPRESSED AUDIO	Compressed audio (such as Dolby Digital, DTS)
NO SIGNAL	No audio signal is input.

9.18.10 Sink device status

Menu Top→OTHERS→MONITOR STATUS
 Values to be displayed [Table 9.53] Sink device status

You can view the status of sink device connected to video output connectors.

[Table 9.53] Sink device status

	All video output connector	Each video output connector
Display	OUT 1 2 3 4 ↕ S N E	[OUT1 MONITOR] H24↕ HDCP 1.4 SUPPORT AAA
Upper	Video output channel	Output channel, output signal, color depth
Lower	HDCP status	HDCP status, error code

■ Output signal and color depth

H24 : HDMI, 24-BIT COLOR
 H30 : HDMI, 30-BIT COLOR
 D : DVI

■ HDCP authorization status

[Table 9.54] HDCP authorization status

Character	HDCP status	Description
S	HDCP 1.4 SUPPORT	HDCP 1.4-compliant sink device is connected.
N	HDCP NOT SUPPORT	Non-HDCP-compliant sink device is connected.
E	HDCP ERROR	HDCP-compliant sink device is connected, but the authorization failed.
C	HDCP CHECK NOW	Sink device status is being checked.
D	MONITOR DISCONNECT	Monitor was disconnected (displayed only for one second).
	UNCONNECTED	No sink device is connected.

■ Error code

From the left to right, status of video output, digital audio output, and analog audio output is displayed.
(Example: AAA)

[Table 9.55] Error code

Code	Video output	Audio output
	If any number or character is not displayed, video or audio is output correctly.	
1	—	“9.10.2 Output mute” is set to “ON”.
2	Displayed only for digital input. DDC power supply is not input. (If no source device is connected, this error code is displayed).	
3	No video signal is input.	No video signal is input. *1
4	Displayed only for digital input. Video or audio output of source device is in a Mute status.	
5	Displayed only for digital input. Signal with HDCP are input, but the sink device does not support HDCP. (This error code may also be displayed while authenticating HDCP).	
6	Displayed only for digital input. The source device does not output required information (packets) for outputting video or audio.	
7	Signal that are not supported by the MSD are input. (Sampling clock is out of the range)	Signal that are not supported by the MSD are input. (Sampling clock is out of the range).
8	—	—
9	—	“9.9.2 Output mode” is set to “DVI MODE” or a sink device that does not support audio is connected.*2
A	Input channel is set to “OFF”.	

*1 Input status of analog audio signal cannot be detected. Even if this status is not displayed, audio may sometimes not be output when analog input is selected.

*2 This status is only for HDMI output connectors.

9.18.11 Viewing sink device EDID

Menu Top→OTHERS→EDID STATUS

Values to be displayed [Table 9.56] Sink device EDID

You can display the EDID information of the sink device that is connected to each video output connector.

- HDMI supported sink device : No.1 to No.5 in the table below
- Non-HDMI-supported sink device : No.1 and No.2 in the table below

If no sink device is connected, the VFD screen shows "UNCONNECTED". If the MSD cannot read EDID from connected sink devices, the VFD screen (No.1) shows "EDID READ ERROR".

[Table 9.56] Sink device EDID

No.	1	2	3
Display	[OUT1]xxxx 1920x1080 148.50MHz↕	[OUT1]HDMI RGB/422/444/420 ↕ [OUT1] DVI ↕	[OUT1] 24BIT COLOR ↕
Upper	Monitor name	HDMI or nothing is displayed	—
Lower	Resolution, dot clock	Sampling RGB :RGB 422 :YCbCr 4:2:2 444 :YCbCr 4:4:4 420 :YCbCr 4:2:0 Or Non-HDMI-supported sink device DVI : DVI device	Color depth

No.	4	5
Display	[OUT1] 32/44.1/48/96kHz ↕	[OUT1]16/20/24BIT 8CHANNEL COMPRESSED
Upper	—	Audio bit length
Lower	Audio sampling frequency	Number of audio channels, compressed audio supported/not supported

9.18.12 Viewing version information

Menu Top→OTHERS→VERSION

Values to be displayed Model name and firmware version

You can view the model name and firmware version.

9.19 Setting DANTE (Optional)

Available only if Dante is mounted.

9.19.1 CH61-CH64

Menu Top→DANTE SETTING→CH61-CH64

Setting value IN8 [Default], AUDIO IN1&2

64 channels are reserved for Dante output.

You can select the input audio that is output to Channels 61 to 64.

【See: 8.8 Dante output (Optional)】

[Table 9.57] Dante output channel and audio input channel

Setting value	Dante output channel	Audio input channel
IN8	CH61	IN8-CH5
	CH62	IN8-CH6
	CH63	IN8-CH7
	CH64	IN8-CH8
AUDIO IN1&2	CH61	AUDIO IN1-L
	CH62	AUDIO IN1-R
	CH63	AUDIO IN2-L
	CH64	AUDIO IN2-R

10 Product specification

■ MSD-6203

Item		Description
Input	Video	HDMI / DVI <ul style="list-style-type: none"> 1 input HDMI Deep Color (*1) / DVI 1.0 TMDS single link, HDCP 1.4 TMDS clocks: 25 MHz to 300 MHz, TMDS data rate: 0.75 Gbps to 9 Gbps Built-in cable EQ, EDID emulation Connector: Female HDMI Type A (19-pin)
		HDMI / DVI <ul style="list-style-type: none"> 5 inputs *DVI connectors: Switch-selectable between digital and analog HDMI Deep Color (*1) / DVI 1.0 TMDS single link, HDCP 1.4 TMDS clocks: 25 MHz to 225 MHz, TMDS data rate: 0.75 Gbps to 6.75 Gbps Built-in cable EQ, EDID emulation Connector: 3 female HDMI Type A (19-pin), 2 female DVI-I (29-pin)
		HDBaseT <ul style="list-style-type: none"> 2 inputs HDBaseT (*1) HDCP 1.4 (*2) EDID emulation, PoH power supply (IEEE 802.3af) (*3) Connector: RJ-45 (*4) Cable: CAT.5E HDC, Cat5e UTP / STP, Cat6 UTP / STP (*5)
		Universal Analog <ul style="list-style-type: none"> 2 inputs Switch-selectable between digital and analog Analog RGB: 0.7 V[p-p]/75 Ω, HS/VS TTL level, CS TTL level Analog YPbPr: 1.0 V[p-p](Y)/0.7 V[p-p](Pb/Pr)/75 Ω Separate synch EDID emulation Connector: Female DVI-I (29-pin)
	Format	HDMI / DVI <ul style="list-style-type: none"> 1 input VGA to 4K (Dot clock: 25 MHz to 300 MHz) 480i / 480p / 576i / 576p / 720p / 1080i / 1080p / 4K (up to 4K@30)
		HDMI / DVI <ul style="list-style-type: none"> 5 inputs VGA to QWXGA (Dot clock: 25 MHz to 165 MHz) * For WUXGA / QWXGA, only Reduced Blanking is supported. 480i / 480p / 576i / 576p / 720p / 1080i / 1080p
		HDBaseT <ul style="list-style-type: none"> VGA to 4K (Dot clock: 25 MHz to 300 MHz) 480i / 480p / 576i / 576p / 720p / 1080i / 1080p / 4K (up to 4K@30)
		Universal Analog <ul style="list-style-type: none"> VGA to QWXGA (Dot clock: 25 MHz to 165 MHz) * For WUXGA / QWXGA, only Reduced Blanking is supported. 480i / 480p / 576i / 576p / 720p / 1080i / 1080p
	Audio	Digital <ul style="list-style-type: none"> 8 inputs *Switch-selectable between analog audio Multi-channel LPCM up to 8 channels Sampling frequency: 32 kHz to 192 kHz, Sample size: 16 bit to 24 bit Reference level: -20 dBFS, Max. input level: 0 dBFS Connector: 4 female HDMI Type A (19-pin), 2 RJ-45 (*4), 2 female DVI-I (29-pin)
		Analog <ul style="list-style-type: none"> 2 inputs *Switch-selectable between digital audio Stereo LR balanced / unbalanced Input impedance: 48k Ω Balanced / 24 kΩ Unbalanced Reference level: -10 dBu, Max. input level: +10 dBu Connector: 5-position terminal block

Item		Description
Output	Video	HDMI / DVI 3 outputs *The output video is switch-selectable between HDMI output and HDBaseT output. HDMI Deep Color (*1) / DVI 1.0 TMDS single link, HDCP 1.4 TMDS clocks: 65 MHz to 297 MHz, TMDS data rate: 1.95 Gbps to 8.91 Gbps Built-in cable EQ Connector: Female HDMI Type A (19-pin)
		HDBaseT 3 outputs *The output video is switch-selectable between HDMI output and HDBaseT output. HDBaseT (*1) HDCP 1.4 (*2) Connector: RJ-45 (*4) Cable: CAT.5E HDC, Cat5e UTP / STP, Cat6 UTP / STP (*5)
		Format VGA / WXGA (1280x768) / WXGA (1280x800) / Quad-VGA / SXGA / WXGA (1360x768) / WXGA (1366x768) / SXGA+ / WXGA+ / WXGA++ / UXGA / WSXGA+ / VESAHD / WUXGA / QWXGA * For VESAHD / WUXGA / QWXGA, only Reduced Blanking is supported. 720p / 1080i / 1080p / 4K (3840 x 2160) (*6) / 4K (4096 x 2160) (*6)
	Audio	Digital 3 outputs *The output audio is switch-selectable between HDMI output and HDBaseT output. Multi-channel LPCM up to 8 channels Sampling frequency: 32 kHz to 192 kHz, Sample size: 16 bit to 24 bit Reference level: -20 dBFS, Max. output level: 0 dBFS Connector: 3 female HDMI Type A (19-pin), 3 RJ-45 (*4)
		Analog 1 output 1 of 3 digital audio outputs can be selected to be output as analog audio. Stereo LR balanced / unbalanced Output impedance: 100 Ω balanced / 50 Ω unbalanced Reference level: -10 dBu, Max. output level: +10 dBu Connector: 5-position terminal block
		Network audio (Option) 1 output Format: Dante protocol Sampling frequency: 48 kHz, Sample size: 24 bit The number of outputs: 64 channels Connector: 2 RJ-45 (Primary / Secondary) (*7)
Maximum extension distance	Digital Input HDMI / DVI: 98 ft. (30 m) (1080p@60), 66 ft. (20 m) (4K@30) (*8) HDBaseT: up to 328 ft. (100 m), up to 492 ft. (150 m) (Long reach mode) (*9)	
	Digital output HDMI / DVI: 131 ft. (40 m) (1080p@60), 98 ft. (30 m) (4K@30) (*8) HDBaseT: up to 328 ft. (100 m), up to 492 ft. (150 m) (Long reach mode) (*9)	
Function	Scan Converter Motion adaptive I/P conversion, Aspect Ratio Control, Picture adjustment (brightness, contrast, display position, display size, etc.), Seamless Switching (*10)	
	Others Multiview function (*11), Video mirror reversing (*12), All function setting through browser, Automatic input detection and switching, Volume adjustment (volumes of input and output ports can be set separately), Lip Sync (Max. 16 frames), Audio breakaway enables independent audio and video switching, Cross-point memory (9 settings), Preset memory (12 settings), Last memory, Anti-Snow (*13), Connection Reset (*14), External control commands (32 commands), Security lock	
External control	RS-232C 1 port / 3-position terminal block	
	LAN 1 port / RJ-45 10Base-T / 100Base-TX (Auto Negotiation), Auto MDI / MDI-X	
	Contact closure 9 ports / 6-position terminal block Non-voltage contact input up to DC 24 V 500 mA	
	External control RS-232C, LAN, contact closure, PLink (class1), CEC (Power control of sink device) (*15)	
General	Power 100 - 240 VAC ± 10%, 50 Hz / 60 Hz ± 3 Hz	
	Power consumption About 118 Watts About 125 Watts with Dante (optional)	
	Dimensions 16.9 (W) × 3.5 (H) × 15.7 (D)* (430 (W) × 88 (H) × 400 (D) mm) (EIA 2U high, full rack wide) (Excluding connectors and the like)	
	Weight 14.8 lbs. (6.7 kg) 15.4 lbs. (7 kg) with Dante (optional)	
	Temperature Operating: 32°F to 104°F (0°C to +40°C) Storage: -4°F to +176°F (-20°C to +80°C)	
	Humidity Operating / Storage: 20% to 90% (Non Condensing)	

*1 30 bit / pixel (10 bit / component) Deep Color is supported while x.v.Color, 3D, ARC and HEC are not supported.

WQHD, WQXGA and 4K format: 24 bit / pixel (8 bit / component) is supported.

*2 HDBaseT input/output: DVI signals protected by HDCP are not supported. To transmit those signals, use an IDK's twisted pair cable extender supporting DVI signals.

*3 For PoH power feeding, please use an HDBaseT transmitter supporting IEEE 802.3af. Use an AWG24 twisted pair cable or thicker cable.

*4 RJ-45 (HDBaseT connector) is only for extending digital video and audio signals over a Cat5e / Cat6 twisted pair cable. Use it with IDK's twisted pair cable transmitter or receiver. Do not use for LAN devices.

*5 T568A or T568B straight. The CAT.5E HDC cable is developed by IDK and recommended by HDBaseT alliance.

*6 4K format: Up to 4K@30 is supported.

If multiple sink devices are connected, the same video and audio are output from OUT1 and OUT2.

*7 RJ-45 (Dante connector) is only for outputting audio at the Dante format.

*8 The maximum cable distance varies depending on the connected devices and was measured under following conditions:

• 1080p@60: when IDK's AWG 24 cable was used and signals of 1080p@60 24 bit / pixel (8 bit / component) was input or output.

• 4K@30: when IDK's AWG 24 cable was used and signals of 4K@30 24 bit / pixel (8 bit / component) was input or output.

The maximum cable distance depends on the connected devices. The distance may not be extended with some device combinations, cabling method, or other manufacturer's cable. Video may be disturbed or may not be output even if signals are within the range mentioned above.

*9 The maximum extension distance was obtained when IDK's CAT.5E HDC cable was used. The distance may not be extended with some device combinations, cabling method, or other manufacturer's cable. Video may be disturbed or may not be output even if signals are within the range mentioned above. Operations may not be stable with some LCD devices; please check the operation beforehand or contact us.

The maximum extension distance is the shorter distance of connected HDBaseT product or sink device's maximum extension distance.

Up to 492 ft. (150 m): 1080p (24 bit) in Long reach mode. For Long reach mode, use IDK's twisted pair cable products that supports 328 ft. (100 m) or longer

*10 Seamless switching with a black frame.

*11 If multiple sink devices are connected, the same video signals are output from OUT1, OUT2, and OUT3. 4K format is not supported.

*12 4K format is not supported.

*13 The anti-snow feature automatically fixes snow noise that is a specific symptom of HDCP-compliant signals and mainly occurs at start-up. This feature does not work when snow noise has already occurred during startup or when it occurs due to a bad condition of the transmission line.

*14 For digital systems, some problems, such as an HDCP authentication error, can often be recovered by physically disconnecting and reconnecting the digital cables. However, the Connection Reset feature will fix these problems automatically without the need to physically plug and unplug the cables. It creates the same condition as if the cable were physically disconnected and reconnected. This feature only works for the MSD's output. If other devices are connected between the MSD's output and sink device, this feature may be invalid.

*15 The sink device must support CEC. Some sink devices cannot be controlled from the MSD through CEC.

■ MSD-6204

Item		Description
Input	Video	HDMI / DVI 1 input HDMI Deep Color (*1) / DVI 1.0 TMDS single link, HDCP 1.4 TMDS clocks: 25 MHz to 300 MHz, TMDS data rate: 0.75 Gbps to 9 Gbps Built-in cable EQ, EDID emulation Connector: Female HDMI Type A (19-pin)
		HDMI / DVI 5 inputs *DVI connectors: Switch-selectable between digital and analog HDMI Deep Color (*1) / DVI 1.0 TMDS single link, HDCP 1.4 TMDS clocks: 25 MHz to 225 MHz, TMDS data rate: 0.75 Gbps to 6.75 Gbps Built-in cable EQ, EDID emulation Connector: 3 female HDMI Type A (19-pin), 2 female DVI-I (29-pin)
		HDBaseT 2 inputs HDBaseT (*1) HDCP 1.4 (*2) EDID emulation, PoH power supply (IEEE 802.3af) (*3) Connector: RJ-45 (*4) Cable: CAT.5E HDC, Cat5e UTP / STP, Cat6 UTP / STP (*5)
	Universal Analog 2 inputs Switch-selectable between digital and analog Analog RGB: 0.7 V[p-p]/75 Ω, HS/VS TTL level, CS TTL level Analog YPbPr: 1.0 V[p-p](Y)/0.7 V[p-p](Pb/Pr)/75 Ω, Separate synch EDID emulation Connector: Female DVI-I (29-pin)	
	Format	HDMI / DVI 1 input VGA to 4K (Dot clock: 25 MHz to 300 MHz) 480i / 480p / 576i / 576p / 720p / 1080i / 1080p / 4K (up to 4K@30)
		HDBaseT VGA to 4K (Dot clock: 25 MHz to 300 MHz) 480i / 480p / 576i / 576p / 720p / 1080i / 1080p / 4K (up to 4K@30)
		Universal Analog VGA to QWXGA (Dot clock: 25 MHz to 165 MHz) * For WUXGA / QWXGA, only Reduced Blanking is supported. 480i / 480p / 576i / 576p / 720p / 1080i / 1080p
	Audio	Digital 8 inputs *Switch-selectable between analog audio Multi-channel LPCM up to 8 channels Sampling frequency: 32 kHz to 192 kHz, Sample size: 16 bit to 24 bit Reference level: -20 dBFS, Max. input level: 0 dBFS Connector: 4 female HDMI Type A (19-pin), 2 RJ-45 (*4), 2 female DVI-I (29-pin)
		Analog 2 inputs *Switch-selectable between digital audio Stereo LR balanced / unbalanced Input impedance: 48k Ω Balanced / 24 kΩ Unbalanced Reference level: -10 dBu, Max. input level: +10 dBu Connector: 5-position terminal block

Item		Description
Output	Video	HDMI / DVI 4 outputs *The output video is switch-selectable between HDMI output and HDBaseT output. HDMI Deep Color (*1) / DVI 1.0 TMDS single link, HDCP 1.4 TMDS clocks: 65 MHz to 297 MHz, TMDS data rate: 1.95 Gbps to 8.91 Gbps Built-in cable EQ Connector: Female HDMI Type A (19-pin)
		HDBaseT 4 outputs *The output video is switch-selectable between HDMI output and HDBaseT output. HDBaseT (*1) HDCP 1.4 (*2) Connector: RJ-45 (*4) Cable: CAT.5E HDC, Cat5e UTP / STP, Cat6 UTP / STP (*5)
		Format VGA / WXGA (1280x768) / WXGA (1280x800) / Quad-VGA / SXGA / WXGA (1360x768) / WXGA (1366x768) / SXGA+ / WXGA+ / WXGA++ / UXGA / WSXGA+ / VESAHD / WUXGA / QWXGA * For VESAHD / WUXGA / QWXGA, only Reduced Blanking is supported. 720p / 1080i / 1080p / 4K (3840 x 2160) (*6) / 4K (4096 x 2160) (*6)
	Audio	Digital 4 outputs *The output audio is switch-selectable between HDMI output and HDBaseT output. Multi-channel LPCM up to 8 channels Sampling frequency: 32 kHz to 192 kHz, Sample size: 16 bit to 24 bit Reference level: -20 dBFS, Max. output level: 0 dBFS Connector: 4 female HDMI Type A (19-pin), 4 RJ-45 (*4)
		Analog 1 output 1 of 4 digital audio outputs can be selected to be output as analog audio. Stereo LR balanced / unbalanced Output impedance: 100 Ω balanced / 50 Ω unbalanced Reference level: -10 dBu, Max. output level: +10 dBu Connector: 5-position terminal block
		Network audio (Option) 1 output Format: Dante protocol Sampling frequency: 48 kHz, Sample size: 24 bit The number of outputs: 64 channels Connector: 2 RJ-45 (Primary / Secondary) (*7)
Maximum extension distance	Digital Input HDMI / DVI: 98 ft. (30 m) (1080p@60), 66 ft. (20 m) (4K@30) (*8) HDBaseT: up to 328 ft. (100 m), up to 492 ft. (150 m) (Long reach mode) (*9)	
	Digital output HDMI / DVI: 131 ft. (40 m) (1080p@60), 98 ft. (30 m) (4K@30) (*8) HDBaseT: up to 328 ft. (100 m), up to 492 ft. (150 m) (Long reach mode) (*9)	
Function	Scan Converter Motion adaptive I/P conversion, Aspect Ratio Control, Picture adjustment (brightness, contrast, display position, display size, etc.), Seamless Switching (*10)	
	Others Multiview function (*11), Video mirror reversing (*12), All function setting through browser, Automatic input detection and switching, Volume adjustment (volumes of input and output ports can be set separately), Lip Sync (Max. 16 frames), Audio breakaway enables independent audio and video switching, Cross-point memory (9 settings), Preset memory (12 settings), Last memory, Anti-Snow (*13), Connection Reset (*14), External control commands (32 commands), Security lock	
External control	RS-232C 1 port / 3-position terminal block	
	LAN 1 port / RJ-45 10Base-T / 100Base-TX (Auto Negotiation), Auto MDI / MDI-X	
	Contact closure 9 ports / 6-position terminal block Non-voltage contact input up to DC 24 V 500 mA	
	External control RS-232C, LAN, contact closure, PLink (class1), CEC (Power control of sink device) (*15)	
General	Power 100 - 240 VAC ± 10%, 50 Hz / 60 Hz ± 3 Hz	
	Power consumption About 121 Watts About 129 Watts with Dante (optional)	
	Dimensions 16.9 (W) × 3.5 (H) × 15.7 (D)" (430 (W) × 88 (H) × 400 (D) mm) (EIA 2U high, full rack wide) (Excluding connectors and the like)	
	Weight 14.8 lbs. (6.7 kg), 15.4 lbs. (7 kg) with Dante (optional)	
	Temperature Operating: 32°F to 104°F (0°C to +40°C) Storage: -4°F to +176°F (-20°C to +80°C)	
	Humidity Operating / Storage: 20% to 90% (Non Condensing)	

*1 30 bit / pixel (10 bit / component) Deep Color is supported while x.v.Color, 3D, ARC and HEC are not supported.

WQHD, WQXGA and 4K format: 24 bit / pixel (8 bit / component) is supported.

*2 HDBaseT input/output: DVI signals protected by HDCP are not supported. To transmit those signals, use an IDK's twisted pair cable extender supporting DVI signals.

*3 For PoH power feeding, please use an HDBaseT transmitter supporting IEEE 802.3af. Use an AWG24 twisted pair cable or thicker cable.

*4 RJ-45 (HDBaseT connector) is only for extending digital video and audio signals over a Cat5e / Cat6 twisted pair cable. Use it with IDK's twisted pair cable transmitter or receiver. Do not use for LAN devices.

*5 T568A or T568B straight. The CAT.5E HDC cable is developed by IDK and recommended by HDBaseT alliance.

*6 4K format: Up to 4K@30 is supported.

If multiple sink devices are connected, the actual number of outputs becomes two: OUT1 and OUT2 (as a group) and OUT3 and OUT4 (as another group).

*7 RJ-45 (Dante connector) is only for outputting audio at the Dante format.

*8 The maximum cable distance varies depending on the connected devices and was measured under following conditions:

• 1080p@60: when IDK's AWG 24 cable was used and signals of 1080p@60 24 bit / pixel (8 bit / component) was input or output.

• 4K@30: when IDK's AWG 24 cable was used and signals of 4K@30 24 bit / pixel (8 bit / component) was input or output.

The maximum cable distance depends on the connected devices. The distance may not be extended with some device combinations, cabling method, or other manufacturer's cable. Video may be disturbed or may not be output even if signals are within the range mentioned above.

*9 The maximum extension distance was obtained when IDK's CAT.5E HDC cable was used. The distance may not be extended with some device combinations, cabling method, or other manufacturer's cable. Video may be disturbed or may not be output even if signals are within the range mentioned above. Operations may not be stable with some LCD devices; please check the operation beforehand or contact us.

The maximum extension distance is the shorter distance of connected HDBaseT product or sink device's maximum extension distance.

Up to 492 ft. (150 m): 1080p (24 bit) in Long reach mode. For Long reach mode, use IDK's twisted pair cable products that supports 328 ft. (100 m) or longer.

*10 Seamless switching with a black frame.

*11 If multiple sink devices are connected, the same video signals are output from OUT1, OUT2, OUT3, and OUT4.

*12 4K format is not supported.

*13 The anti-snow feature automatically fixes snow noise that is a specific symptom of HDCP-compliant signals and mainly occurs at start-up. This feature does not work when snow noise has already occurred during startup or when it occurs due to a bad condition of the transmission line.

*14 For digital systems, some problems, such as an HDCP authentication error, can often be recovered by physically disconnecting and reconnecting the digital cables. However, the Connection Reset feature will fix these problems automatically without the need to physically plug and unplug the cables. It creates the same condition as if the cable were physically disconnected and reconnected. This feature only works for the MSD's output. If other devices are connected between the MSD's output and sink device, this feature may be invalid.

*15 The sink device must support CEC. Some sink devices cannot be controlled from the MSD through CEC.

11 Troubleshooting

This chapter recommends what to do if you have problems operating the MSD.

In case the MSD does not work correctly, please check the following items first.

- Are the MSD and all devices plugged in and powered on normally?
- Are cables connected correctly?
- Are there no loose connections?
- Are correct cables supported by devices being used?
- Are specifications of connected devices matched to each other?
- Are settings of the sink device correct?
- Are there any nearby objects that may cause noise?

If the problem still cannot be solved, perform the following actions. Refer to manuals of connected devices as well, since they may possibly be the cause of the problem.

Problem	Cause/Check item/Solution	Page
●Video output		
Video is not output.	<p>Check the error code in “9.18.10 Sink device status”.</p> <p>(Since the MSD has multiple output connectors, check the error code of the output connector that does not output video.)</p> <ul style="list-style-type: none"> • Error code 2: Check if the source device is connected and powered on. • Error code 3: Signal is not input. Check [1] to [6] on the next page. • Error code 4: A problem may occur in the source device or HDCP authentication. Check [2], [5] and [6]. • Error code 5: If the display device or AV amplifier does not support HDCP, only audio without content protection (such as analog input) is output; audio is not output when signal with content protection is input. Some HDMI/DVI devices check if the connected device is HDCP compliant and determines whether to output HDCP signal or not. Since the MSD is HDCP compliant, audio may not be output if the MSD is connected to a sink device or AV amplifier that does not support HDCP. In this case, disable HDCP input from the input device in “9.7.2 HDCP input setting”. • Error code 6 and 7: A problem occurs in the source device. • Error code A: Set “8.2 Selecting input channels” to a value other than “OFF”. • If no error code is displayed: Set “9.4.11 Test pattern” to a pattern other than “OFF”. - If any test pattern is not output, check [5] to [7]. - If a test pattern is output, the source device may not output video. 	—

Problem	Cause/Check item/Solution	Page
Digital input video is not output.	[1] The set time for monitoring no-signal input may be too short.	75
Analog input video is not output.	[3] Change the input signal type.	77
Video is not output	[4] If the source device has multiple output connectors, check the video output settings of the source device.	—
Video is disappeared, interrupted, or has noise.	[5] If using a long cable for input or output, replace it with a 16 ft. (5 m) or shorter cable. Since the MSD has the equalizing function, long cables can be connected, but the MSD may not provide its full performance depending on the cable quality and the connected device. If the problem is solved by replacing the cable, signal may have been degraded due to the long haul transmission. We have high-quality cables, cable boosters and extenders. Please contact us as needed.	—
	[6] When high-speed signal (high resolution: such as UXGA, WUXGA, QWXGA, WQHD, WQXGA, 1080p, 4K; DEEP COLOR signal) is input or output, video may not be displayed or noise may appear depending on the cable quality and the connected device. If the problem occurs only when a specific input is selected, the problem was caused by the input side. If it occurs for all inputs or only when a test pattern is displayed, the problem was caused by the output side. Change the resolution to a lower level and/or disable Deep color. You can check the resolution and color depth of the input signal in “ 9.18.9 Input signal status ” and you can also limit resolution and color depth of input signal according to the EDID setting. You can specify the output resolution and check the color depth of the output signal in “ 9.18.10 Sink device status ” and you can also limit the output signal color depth.	102, 104, 105 63 91
Input video and test pattern are not output.	[7] If you set the output resolution other than “AUTO-A”, check if the selected resolution is supported by the sink device. If you select “1080i”, video may not be output to sink devices that do not support interlaced signal. For TV output resolutions (480i to 4K (4096 x 2160)), check the vertical sync frequency. PC output resolutions (VGA to WQXGA) may not be output to LCD TVs.	63
Video is interrupted.	If you set “ 9.7.4 Automatic detection of video input interruption ” to “ON”, false detection may occur. Change the setting to “OFF”.	78
Video from HDMI/DVI output is interrupted or has noise.	If the problem occurs in all input channels or when a test pattern is displayed, replace the cable with a shorter one.	—

Problem	Cause/Check item/Solution	Page
Video from analog input is displayed in black-and-white or green.	Change the input signal type.	77
The left, right, top and bottom sides are cut off.	If the problem occurs only when "CROSS HATCH" (a test pattern) is output, the sink device enlarges and displays the video. Adjust the sink device. If the sink device does not have the adjusting function, set the video size and position of the output. If the problem occurs even if "CROSS HATCH" is output to all outputs, check [8] to [13].	68 65, 66
Part of video is cut off or black is displayed at edge(s).	[8] Check the overscan setting.	65
	[9] Settings of the display position or size are not changed? Note: Display position and size can be set for each input or output.	65, 66
	[10] If aspect ratios of the input signal and output resolution do not match, video may be cut off automatically or black may be displayed at edge(s) depending on settings. If the video is displayed on the full screen by setting the aspect ratio to "FULL", there is no problem. If the aspect ratios are not the same, you can select a) or b) below: a) video is cut off b) black is displayed at edge(s)	64 65
	[11] If vertical and horizontal frequencies are displayed in "9.18.9 Input signal status", signal that is not registered in the built-in data of the MSD is input. If "9.8.6 Automatic setting of input timing" is set to "AUTO SETUP ON", input timing is measured when new signal is input. However, if correct video is not input, the measurement may fail. In this case, measure the input timing manually and register the device data.	81, 86
	[12] For analog input, set the automatic measurement of input timing in "9.8.1 Automatic measurement". If the result of the automatic measurement shows that video is cut off or black is displayed at edges, set the total number of the horizontal dots, scanning start position, and the active area. For digital input, the start position and active area do not have to be set. Only when video edges are cut off 1 to 2 dots, set these items. (For digital input, the total number of horizontal dots cannot be set).	83, 84

Problem	Cause/Check item/Solution	Page
Black is displayed at top, bottom, right and left on PC video or only part of the PC video is displayed, and the rest is displayed by scrolling with the mouse.	[13] Does the PC resolution (you can check it in "Properties" of the PC) match the resolution that is output from the PC (you can check it in " 9.18.9 Input signal status "). If not, set the EDID and PC resolutions. If the copy of the built-in LCD screen is output in the laptop, the output to an output monitor is limited to the resolution of the LCD screen. As a result, black may be displayed at edges. The problem can be solved by enlarging the display or displaying only to the external monitor.	101, 102
Video is reduced vertically or horizontally.	Does the selected aspect ratio of the output resolution match that of the connected sink device? If not, set the aspect ratio of the sink device.	64
	Check the set aspect ratio of the input signal.	64
	Check the monitor setting of the source device (such as 4:3, 16:9, letter box and the like).	—
	For analog input, signal that cannot be recognized by the MSD and wrong aspect ratio may be applied. Perform the automatic measurement in the "NEXT ASPECT" mode.	81
Video flickers	If interlace signal is input to a sink device that does not support interlace signal, the video may flicker. Check the output resolution of the sink device.	63
PC's dual monitor cannot be set or the setting is canceled.	If the monitoring function for no-signal input works, the dual monitor function may not work correctly. In this case, disable the monitoring function.	75
It takes a long time to output video after video input is switched.	If you set the HDCP output to "HDCP INPUT ONLY", some sink devices may fail HDCP authentication. In this case, it may temporarily not output video and audio when a channel signal without HDCP support is input and then is switched to a channel signal with HDCP support is input. In this case, set the HDCP output setting to "ALWAYS".	90
Video from a PC of analog input is displayed with bright-and- dark vertical stripes	Set the total number of horizontal dots. If you change the total number of horizontal dots, you may sometimes have to set the start position of scanning and the active area.	83
Light shadows appear on a few video lines from an analog input PC.	Adjust the tracking.	86
Fluctuation appears on the analog input video.	Adjust the tracking.	86
Automatic measurement of input timing fails.	In order to execute the automatic measurement of the input timing, the input video must have 25% or more brightness and its edges (all sides) need to be in contact with the circumscribed rectangle in the effective display area.	81

Problem	Cause/Check item/Solution	Page
Display position of analog input video changes on its own.	If the function that automatically adjusts the display position (upper left of the screen) works while the automatic measurement is executed, the video may move on its own. In this case, disable the adjusting position function.	85
Part of the bitmap is cut off, or bitmap is not displayed on the full screen.	Set the total number of horizontal dots. If you change the total number of horizontal dots, you may sometimes have to set the start position of scanning and the active area.	135

Problem	Cause/Check item/Solution	Page
●Audio output		
Audio is not output.	<p>If audio is not output, first check the error code in “9.18.10 Sink device status”. (The MSD has multiple output connectors. Find the error code of the output connector that does not output audio.)</p> <ul style="list-style-type: none"> ▪ Error code 1: Set “9.10.2 Output mute” to “OFF”. ▪ Error code 2: Ensure that the source device is connected and powered on. ▪ Error code 3: Signal is not input. Check [14], [15], [17] and [18]. ▪ Error code 4: There may be problems in the source device side or HDCP authentication. Check [14]. ▪ Error code 5: If the display device or AV amplifier does not support HDCP, only video without content protection (such as analog input) is output; video is not output when signal with content protection is input. Some HDMI/DVI devices check if the connected device is HDCP compliant and determines whether to output HDCP signal or not. Since the MSD is HDCP compliant, audio may not be output if the MSD is connected to a sink device or AV amplifier that does not support HDCP. In this case, disable HDCP input from the input device in “9.7.2 HDCP input setting”. ▪ Error code 6: There are problems in the source device. ▪ Error code 7: LCD monitors may not output compressed audio, such as Dolby Digital, DTS, and so on. If playing contents with compressed audio (such as Blu-ray disc), check the audio output setting. Audio signal that is output from the source device can be controlled by setting EDID. ▪ Error code 9: Set “9.9.2 Output mode” to a mode other than “DVI MODE”. If the sink device does not support HDMI signal, the MSD outputs DVI signal automatically. Check which signal type is supported by the sink device. ▪ Error code A: Set “8.2 Selecting input channels” to “OFF”. ▪ If any error code is not displayed: Check [14] to [18]. The source device may not be outputting audio. 	105

Problem	Cause/Check item/Solution	Page
Audio is not output from digital input.	[14] Is video being output correctly? If not, check [1], [2], [5] and [6].	—
	[15] Is DVI signal output from the source device? You can check the input signal type in “ 9.18.9 Input signal status ”. DVI signal may be output depending on EDID settings. If a source device that does not support 4K is connected to the input connector to which 4K EDID is set, DVI signal may be output. Change the setting of “ 9.11.2 Resolutions for PCs ” and “ 9.11.3 Input resolution for AV devices ”.	104 102 104
	[16] Is the input audio format supported by the connected sink device or AV amplifier input? LCD monitors, especially, may not output 88.2 kHz or higher sampling frequency of linear PCM and compressed audio (such as Dolby Digital, DTS, and so on). Audio signal output from the source device can be controlled by setting EDID.	149 105
Audio of input connector is not output.	[17] Is the selection of digital audio input and analog audio input correct?	97
Audio is not output.	[18] If the source device has multiple output connectors, check the audio output settings of the selected output device.	—
Audio is output from digital output connectors but not from analog output connectors.	If compressed audio (such as Dolby Digital, DTS, and so on) is input, analog audio is not output. You can check the input audio type in “ 9.18.9 Input signal status ”.	93
		105
Audio is output from analog output connectors but not from digital output connectors.	If the output resolution is set to a value other than “AUTO-A”, make sure that the sink device or AV amplifier supports the selected output resolution. If a PC output resolution (XGA to 4K) is selected, some sink devices and AV amplifiers cannot output audio. If the sampling frequency is set to a value other than “AUTO”, make sure that the sampling frequency is supported by the sink device or AV amplifier. Some LCD monitors may not output audio whose sampling frequency is high (88.2 kHz or higher).	63
		98
Compressed audio (such as Dolby Digital, DTS) is not output from the source device.	Compressed audio input is set to OFF (EDID settings) by factory default. If using compressed audio, change the EDID setting.	105
	In order to output compressed audio of multi-channel, set the number of speakers.	106
	Check the audio output settings of the source device.	—
Multi-channel audio is not output.	In order to output multi-channel audio, set the number of speakers.	106
Audio of only a specific scene is not output from digital input	Is “DOWN MIX” is set for multi-channel audio output? For multi-channel audio, since channels changes depending on scenes, audio may not output if audio is not included in the set channel.	99

Problem	Cause/Check item/Solution	Page
●Key operation		
Keys do not operate.	Ensure that keys are not locked.	39
	Since no control command is registered by Factory default, "DISPLAY POWER" keys do not work. Register and associate control commands in order to enable these keys.	116, 124
	When a control command is executed using a front panel key, all keys are disabled until the command is executed or "INVALID TIME" passes.	126
	Check the set time of "POWER SWITCH ON" that prevent accidental operation.	146
	Immediately after start-up, all keys are disabled until the connection of the sink device is confirmed.	30
Settings are not saved or reflected to the actual operation.	Settings of some menus may not be saved if the "MENU/SET" key is not pressed after setting.	37
●Communication command control		
Communication command control from the PC to the MSD cannot be performed.	Are the following items set correctly? For RS-232C: baud rate and data length For LAN : IP address and subnet mask	108 111, 113
	Is COM PORT's FUNCTION set to "RECIEVER" mode? If it is set to "TRANSMITTER" mode, the communication command of the MSD cannot be controlled externally.	108, 112
"@ERR,6" is returned.	If control commands are executed by communication commands, the communication command controls are disabled until control commands executed or "INVALID TIME" passes.	126
	Immediately after start-up, the communication command control function is disabled until the connection of the sink device is confirmed.	30
●Sending control command function		
Control command is not sent.	Ensure that the registered control command and the number of bytes are correct. Devices requiring delimiters may not execute commands if the delimiters are not sent. If the set number of bytes is not correct, the control command is not sent completely or unnecessary data is sent after the control command.	116
	Is the registered control command linked to the desired control command execution condition?	124
	Is COM PORT's FUNCTION set to "RECIEVER" mode? In order to send the control command, set the communication port to "TRANSMITTER" mode. If using LAN, set the IP address and other settings of the connected device.	108, 112

Problem	Cause/Check item/Solution	Page
“RETRY OVER ERROR” is displayed and control command is not sent completely.	Is the registered reply command correct?	121
	Ensure that the setting of “TIME OUT” for checking control commands is not too short.	116
Control through CEC cannot be performed.	Does the cable support CEC? In order to use CEC, use an HDMI cable that supports CEC.	—
	Does the sink device support CEC? Is the HDMI link function of the sink device set to be enabled? Enable the HDMI link control of the sink device and the function which powers on the sink device from external devices of the sink device.	
●Others		
Input signal temporarily disappear when input channel is switched.	When the CEC connection changes, EDID may change. In this case, input signal is interrupted. Check the CEC connection settings.	92
Devices cannot be controlled through CEC.	Are HDMI cables supporting CEC being used?	92
	To use CEC, enable HDMI link control of the connected devices (such as LCD TVs, Blu-ray recorder, and so on).	

If additional assistance is required, please perform the following tests and then contact us.

1. Does the same problem occurs at all connectors?
2. Connect the devices using genuine cables without connecting the MSD.
The problem still cannot be solved? Please contact us for assistance.

User Guide of MSD-62 Series

Ver.2.7.0

Issued on: 9 January 2026



Headquarters

IDK Corporation
7-9-1 Chuo, Yamato-shi, Kanagawa-pref.
242-0021 JAPAN
TEL: +81-46-200-0764 FAX: +81-46-200-0765

Email: idk_eng@idk.co.jp

URL: www.idkav.com

USA

IDK America Inc.
72 Grays Bridge Road Suite 1-C, Brookfield, CT 06804
TEL: +1-203-204-2445

Email: sales@idkav.com

URL: www.idkav.com

Europe

IDK Europe GmbH
Lise-Meitner-Str. 6, D-40878 Ratingen
TEL: +49-2102-578-301-0

Email: info@idkav.eu

URL: www.idkav.com



Product information Support

Arvanics Corporation
7-9-1 Chuo, Yamato-shi, Kanagawa-pref.
242-0021 JAPAN
TEL: +81-46-259-6920 FAX: +81-46-259-6930

Email: info@arvanics.com

URL: www.arvanics.com

Information in this document is subject to change without notice.

©2018 IDK Corporation, all rights reserved. All trademarks mentioned are the property of their respective owners.