

Digital Multi Switcher

MSD-S Series

MSD-S51/MSD-S52/MSD-S71/MSD-S72

<Command Reference Guide>

Ver.1.6.0

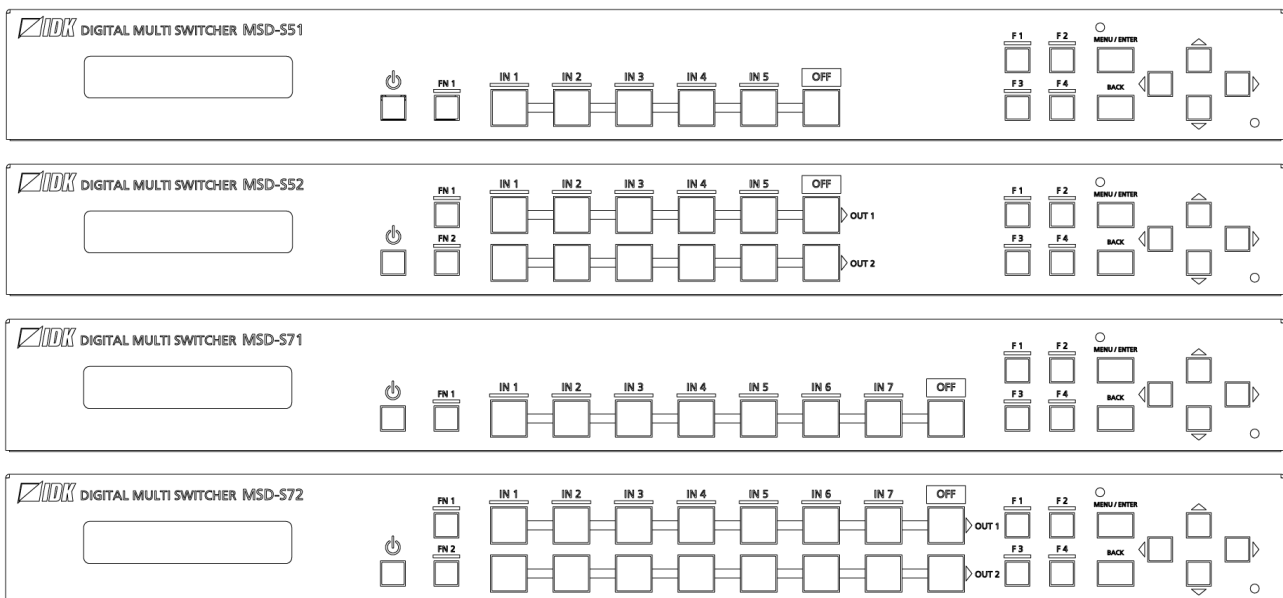

- Thank you for choosing our product.
- To ensure the best performance of this product, please read this user guide fully and carefully before using it and keep this manual together with the product for future reference as needed.

Trademarks

- HDBaseT™ and the HDBaseT Alliance Logo are trademarks of the HDBaseT Alliance.
- The terms HDMI and HDMI High-Definition Multimedia Interface, and the HDMI Logo are trademarks or registered trademarks of HDMI Licensing Administrator, Inc. in the United States and other countries.
- SDVoE™ and SDVoE logo are trademarks of SDVoE Alliance.
- All other company and product names mentioned in this document are either registered trademarks or trademarks of their respective owners. In this document, the “®” or “™” marks may not be specified.
- ©2021 IDK Corporation, all rights reserved.

Before reading this manual

- All rights reserved.
- Some information contained in this Command guide such as exact product appearance, communication commands, and so on may differ depending on the product version.
- This Command guide is subject to change without notice. You can download the latest version from IDK's website at: www.idkav.com

The reference manual consists of the following two volumes:

- User guide: Please download the User guide from the website above.
Provides explanations and procedures for operations, installation, connections among devices, I/O adjustment and settings.
- Command guide (this document):
Provides explanations and procedures for external control using RS-232C and LAN communications.

Table of Contents

1	About this Guide	5
2	Communication configuration and Specifications	5
2.1	RS-232C communication	5
2.1.1	RS-232C connector specification	5
2.1.2	RS-232C communication specification	5
2.1.3	Setting up RS-232C communication	6
2.2	LAN communication	7
2.2.1	LAN connector specification	7
2.2.2	LAN communication specification	7
2.2.3	Setting up LAN communication	8
2.2.4	The number of TCP-IP connections	10
3	Command	11
3.1	Summary	11
3.2	Command list	12
3.3	Details of commands	17
3.3.1	Error status	17
3.3.2	Power status	18
3.3.3	Selecting I/O channels	19
3.3.4	Output position, size, and masking	23
3.3.5	Output	32
3.3.6	Input position, size, and masking	42
3.3.7	Input	47
3.3.8	Input timing	53
3.3.9	Input channel automatic switching	63
3.3.10	Picture controls	67
3.3.11	Output audio	74
3.3.12	Input audio	81
3.3.13	EDID	85
3.3.14	RS-232C	92
3.3.15	LAN	94
3.3.16	Control commands	98
3.3.17	Preset memory	113
3.3.18	Bitmap	121
3.3.19	Overlay bitmap	129
3.3.20	Configuring MSD-S	133
3.3.21	Status	135

1 About this Guide

This guide contains the procedure for controlling the MSD-S51/S52/S71/S72 (hereafter referred to as “MSD-S”) using commands via RS-232C communication or LAN communication.

2 Communication configuration and Specifications

2.1 RS-232C communication

2.1.1 RS-232C connector specification

Insert and secure the wires from the RS-232C cable into the supplied 3-pin captive screw connector, and then insert the captive screw connector into the mating connector on the MSD-S.

24 AWG to 16 AWG conductor gauge is recommended. The recommended wire strip length is 0.28 in. (7 mm). Short RTS/CTS and DTR/DSR as needed.

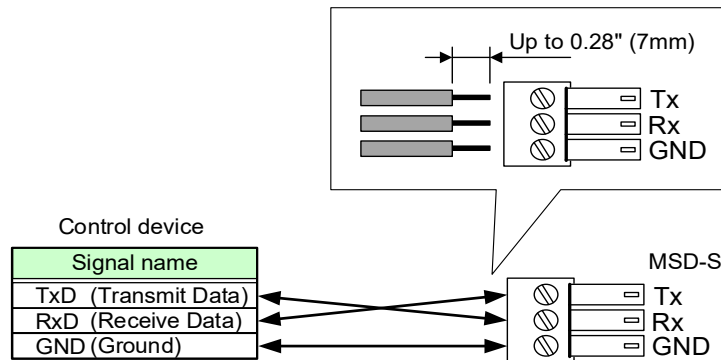

[Fig. 2.1] RS-232C connector

2.1.2 RS-232C communication specification

[Table 2.1] RS-232C specification

Compliant standard	RS-232C
Baud rate	4800/9600/14400/19200/38400/57600/115200 [bps]
Data bit length	7/8 [bit]
Parity check	NONE, ODD, EVEN
Stop bit	1/2 [bit]
X parameter	Invalid
Flow control	None
Delimiter	CR LF (Carriage return and line feed, 0D and 0A in hex)
Communication method	Full duplex

2.1.3 Setting up RS-232C communication

- (1) Connect the MSD-S and the control device via an RS-232C cable.
 - (2) Set the RS-232C communication as follows:
 - RS-232C communication : Baud rate, data bit length, parity check, and stop bit
 - Operation mode of RS-232C communication : RECEIVER mode
- 【Reference: User Guide】
- (3) For the control device, set the same values in the same way as RS-232C communication (baud rate, data bit length, parity check, and stop bit) in step (2) above.
 - (4) Send a communication command from the control device to the MSD-S in order to check the control status of the MSD-S.

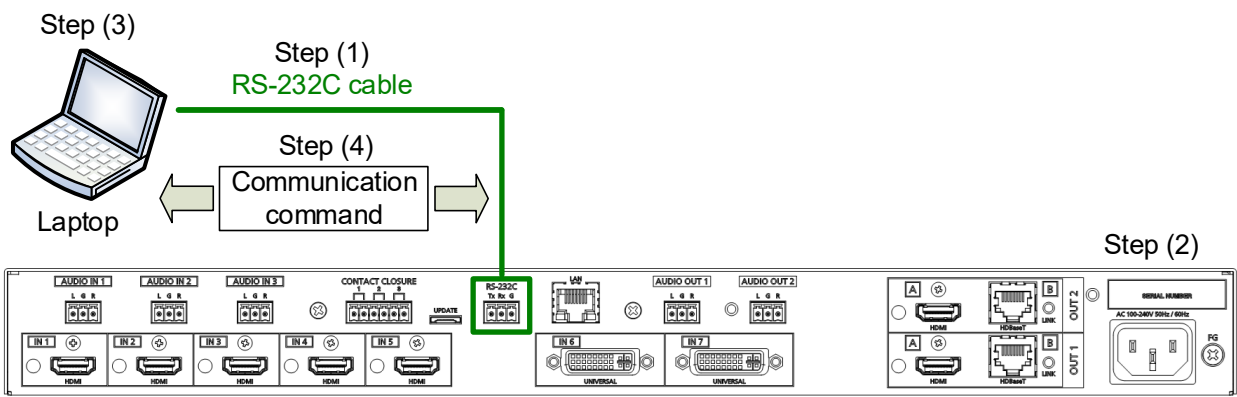

[Fig. 2.2] Setting RS-232C communication

■ Operation example of RS-232C communication

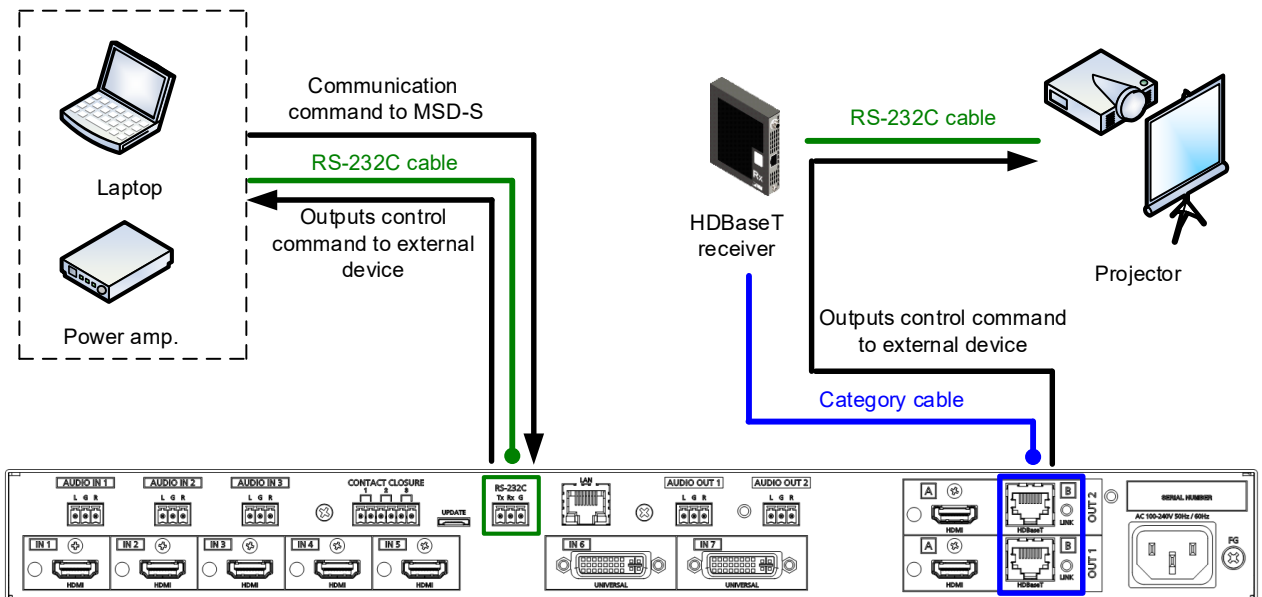

[Fig. 2.3] Example of RS-232C communication

2.2 LAN communication

2.2.1 LAN connector specification

Pin assignment of the LAN connector is as follows.

Since Auto MDI/MDI-X that distinguishes and switches straight/cross cables automatically is supported, extra care is not necessary to connect the MSD-S to PC, HUB or the like.

Light in amber if the send/receive rate is 100 Mbps.
Goes off if it is 10 Mbps.

Light in green while link is established.
Blinks in green while data is being sent/received.

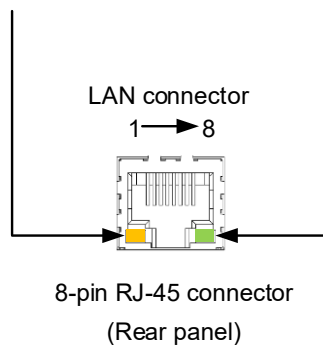

Pin#	Signal Name	
	MDI	MDI-X
1	TX+ (Transmitted Data +)	RX+ (Received Data +)
2	TX- (Transmitted Data -)	RX- (Received Data -)
3	RX+ (Received Data +)	TX+ (Transmitted Data +)
4	N.C. (Not Connected)*	N.C. (Not Connected)*
5	N.C. (Not Connected)*	N.C. (Not Connected)*
6	RX- (Received Data -)	TX- (Transmitted Data -)
7	N.C. (Not Connected)*	N.C. (Not Connected)*
8	N.C. (Not Connected)*	N.C. (Not Connected)*

*Not used

[Fig. 2.4] LAN connector

2.2.2 LAN communication specification

[Table 2.2] Specification of LAN communication

Physical layer	10Base-T (IEEE802.3i)/100Base-TX (IEEE802.3u)
Network layer	ARP, IP, ICMP
Transport layer	TCP Port used for command control : 23, 1100, 6000 to 6999 Port used for WEB browser control(HTTP) : 80, 5000 to 5999

Note:

Up to 8 connections can be used simultaneously.

LAN communication of HDBT OUT1B and HDBT OUT2B is available when the MSD-S is powered on.

2.2.3 Setting up LAN communication

- (1) Connect the MSD-S and the control device via a LAN cable.
- (2) Set up LAN communication as follows:
 - Set IP address and subnet mask
 - Operation mode of LAN communication : RECEIVER mode
 - TCP port number : 23, 1100, 6000 to 6999

【Reference: User guide】

- (3) Establish the connection from the control device to the IP address and TCP port that are set to the MSD-S in step (2) above.
- (4) Send a communication command from the control device to the MSD-S in order to check the control status of the MSD-S.

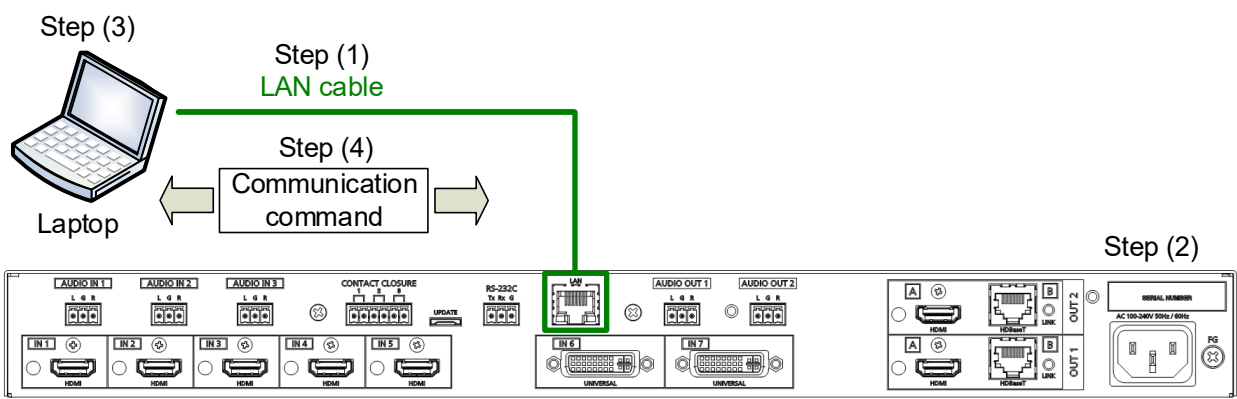

[Fig. 2.5] Setting LAN communication

■ Operation example of LAN communication

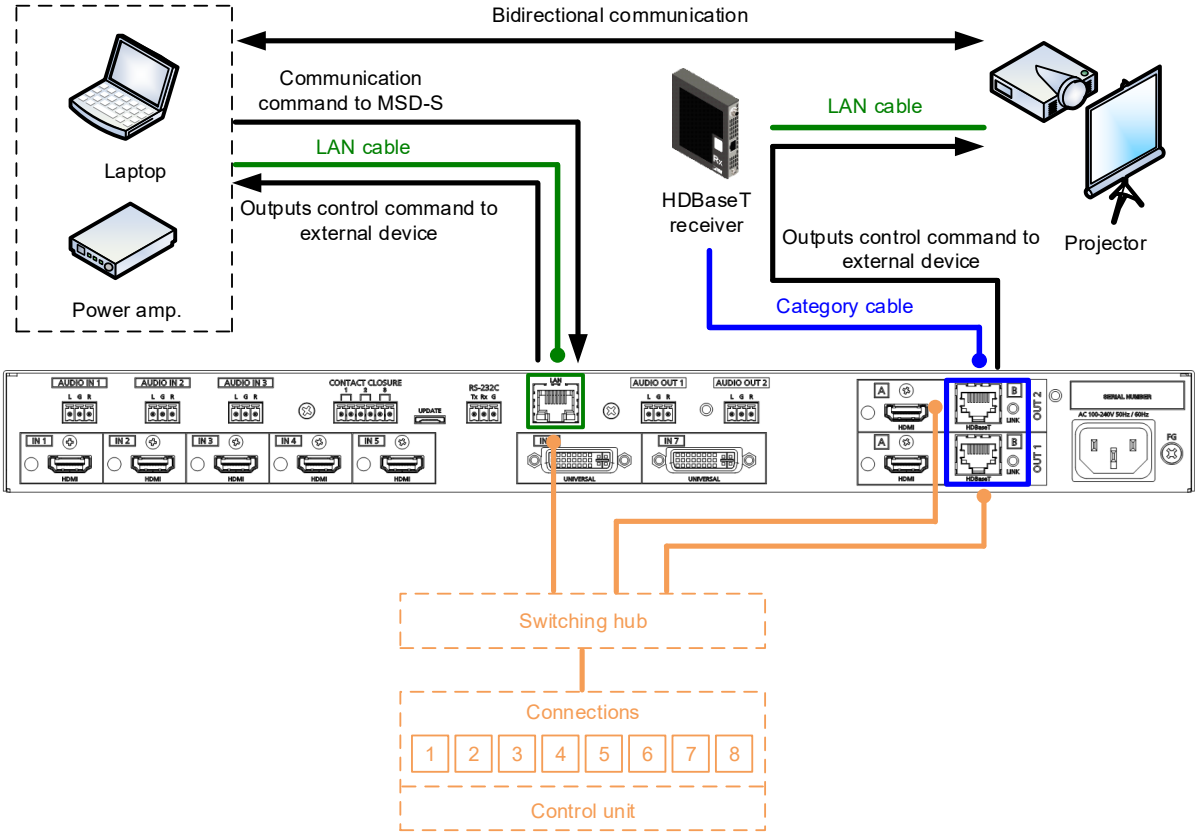

[Fig. 2.6] Example of LAN communication

2.2.4 The number of TCP-IP connections

The MSD-S supports up to eight simultaneous TCP-IP connections (eight logical ports). To maintain optimal system accessibility, it is advisable to issue “port-open” and “port-close” commands before and after command or query strings are issued. This approach enables eight or more control devices to be effectively interfaced simultaneously and without concern for communication errors.

[Table 2.3] Increasing connections

Your PC software		MSD-S
Connecting TCP-IP	→	(Occupying 1 port)
Sending command (@xxx)	→	
	←	Replying command (@xxx)
Closing TCP-IP	→	(Releasing 1port)

Note:

As a safeguard, the MSD-S incorporates a 30-second timeout window for each port. If any port is inactive for more than 30 seconds, it will be closed automatically.

3 Command

3.1 Summary

A command consists of “@” (“40” in hexadecimal), 3 one-byte alphabetical characters (upper and lower cases), and parameters.

“,” (a comma, “2C” in hex) is indicated between two characters.

“␣” is indicated as a delimiter CR LF (return+line feed, “0D” and “0A” in hex).

Processing is executed by sending a delimiter at the end of the command.

Example: @SPM,2 ␣

■ If there is an error:

An error command is returned if an undefined command or wrong format is included.

Example: @ABC,1 ␣

@ERR,1 ␣

■ Using as HELP

If only delimiter is sent, command list as the help command is returned.

3.2 Command list

■ Error status

Command	Function	Page
@ERR	Error status	17

■ Power status

Command	Function	Page
@GDS / @SDS	Power status	18

■ Selecting I/O channels

Command	Function	Page
@GSW / @SSW	Switching video and audio channel simultaneously	19
@GPW / @SPW	Switching video and audio channel simultaneously (PIP windows included)	20
@GSV / @SSV	Switching video channel	21
@GSA / @SSA	Switching audio channel	22
@GPI / @SPI	Layout pattern	22

■ Output position, size, and masking

Command	Function	Page
@GOT / @SOT	Output resolution	23
@GTD	Actual output resolution	24
@GUM / @SUM	Aspect ratio for window	25
@GOP / @SOP	Image position	26
@GOS / @SOS	Image size	27
@GOM / @SOM	Cropping	28
@GBC / @SBC	Background color	29
@GTP / @STP	Test pattern	30
@OAS	Image Initialization	31

■ Output

Command	Function	Page
@GVO / @SVO	Output signal	32
@GBO / @SBO	Output video for when no input video	33
@GEN / @SEN	HDCP output	34
@GHR / @SHR	HDCP retries	35
@HAU	HDCP re-encryption	35
@GEQ / @SEQ	Output equalizer	36
@GDM / @SDM	Output format	37
@GOA / @SOA	HDBaseT output long reach mode	38
@GFF / @SFF	Window transition effect	39
@GFT / @SFT	Window transition speed	40
@GCE / @SCE	CEC connection	41

■ Input position, size, and masking

Command	Function	Page
@GAP / @SAP	Aspect ratio	42
@GAR / @SAR	Aspect ratio control	43
@GOV / @SOV	Overscan	43
@GNP / @SNP	Image position	44
@GNS / @SNS	Image size	45
@GNM / @SNM	Cropping	46
@IAS	Image initialization	46

■ Input

Command	Function	Page
@GIN / @SIN	DVI input connector signal	47
@GDT / @SDT	No-signal input monitoring	48
@GHE / @SHE	HDCP input	49
@GIQ / @SIQ	Input equalizer	49
@GAI / @SAI	Analog input signal parameters	50
@GID / @SID	Automatic detection of video input interruption	51
@GFX / @SFX	Fixing settings for each input signal	52

■ Input timing

Command	Function	Page
@AIS / @AIT	Automatic measurement	53
@GHT / @SHT	The total number of horizontal pixels	54
@GHS / @SHS	Horizontal start position	55
@GHD / @SHD	Horizontal active area	56
@GVS / @SVS	Vertical start position	57
@GVD / @SVD	Vertical active area	58
@GIS / @SIS	Automatic measurement of start position	59
@GSM / @SSM	Automatic setting of input timing	59
@RTT	Initializing digital input timing/Recalling analog input timing	60
@STT	Saving analog input timing	61
@GTK / @STK	Tracking	62

■ Input channel automatic switching

Command	Function	Page
@GAU / @SAU	Signal ON priority	63
@GOF / @SOF	Signal OFF priority	64
@GMT / @SMT	Ignoring duration after automatic switching	65
@GAD / @SAD	Channel switching mode of automatic switching	66

■ Picture controls

Command	Function	Page
@GOB / @SOB	Output brightness	67
@GOC / @SOC	Output contrast	68
@GGM / @SGM	Output gamma	69
@ODC	Output video correction initialization	69
@GFL / @SFL	Input sharpness	70
@GIB / @SIB	Input brightness	70
@GIC / @SIC	Input contrast	71
@GHU / @SHU	Input hue	71
@GST / @SST	Input saturation	72
@GSU / @SSU	Input black level	72
@IDC	Input video correction initialization	73

■ Output audio

Command	Function	Page
@GUC / @SUC	Output audio	74
@GAV / @SAV	Output audio level	75
@SOL	Adjusting output audio level	75
@GOL	Output audio limit status	76
@GAM / @SAM	Audio mute	76
@GLO / @SLO	Output Lip Sync	77
@GSF / @SSF	Sampling frequency	78
@GFD	Actual sampling frequency	78
@GMD / @SMD	Multi-channel audio output	79
@GCH / @SCH	Multi-channel audio output priority	79
@GAT / @SAT	Test tone	80

■ Input audio

Command	Function	Page
@GAS / @SAS	Input audio	81
@GIO / @SIO	Input audio level offset (For each audio input connector)	82
@GSO / @SSO	Input audio level offset (For each audio input channel)	82
@SDZ	Adjusting input audio level	83
@GDZ	Input audio limit status	83
@GLY / @SLY	Input Lip Sync	84
@GAW / @SAW	Stable input audio wait	84

■ EDID

Command	Function	Page
@GED / @SED	EDID selection	85
@GVF / @SVF	Resolution	86
@RME	Copying EDID	87
@GHL / @SHL	HDMI/DVI	87
@GHZ / @SHZ	Frame rate	88
@GAF / @SAF	Audio format	89
@GSP / @SSP	Speaker configuration	90

■ RS-232C

Command	Function	Page
@GCT / @SCT	RS-232C communication	92
@GCF / @SCF	RS-232C operation mode	93

■ LAN

Command	Function	Page
@GIP / @SIP	IP address	94
@GSB / @SSB	Subnet mask	94
@GGW / @SGW	Gateway address	95
@GMC	MAC address	95
@GLP / @SLP	TCP port number	96
@GLF / @SLF	LAN operation mode	97

■ Control commands

Command	Function	Page
@GEC / @SEC	Registering/Editing control command (Communication command)	98
@GEC / @SEC	Registering/Editing control command (Displaying received data)	100
@GEC / @SEC	Registering/Editing control command (Contact closure)	102
@GEC / @SEC	Registering/Editing control command (CEC)	103
@GRC / @SRC	Registering/Editing reply command	104
@GCC / @SCC	Command link	105
@GTG / @STG	Toggle operation	107
@GUP / @SUP	Plane to be executed when powered ON	107
@EXC	Command execution	108
@GSK / @SSK	FN button status	108
@DEC	Initializing registered command and link	109
@GIT / @SIT	Invalid duration at control command execution	109
@GTL / @STL	Illuminating function buttons	110
@GTF / @STF	Function button blinking duration	111
@GFA / @SFA	Assigning function	112

■ Preset memory

Command	Function	Page
@RCM	Recalling crosspoint memory	113
@RCV	Recalling crosspoint memory (Setting video input channel)	113
@RCA	Recalling crosspoint memory (Setting audio input channel)	113
@SCM / @SEM	Saving crosspoint memory	114
@SCV / @SEV	Saving crosspoint memory (Setting video input channel)	115
@SCA / @SEA	Saving crosspoint memory (Setting audio input channel)	116
@GCM / @ECM	Editing crosspoint memory	117
@GCV / @ECV	Editing crosspoint memory (Setting video input channel)	118
@GCA / @ECA	Editing crosspoint memory (Setting audio input channel)	119
@RPM	Recalling preset memory	119
@SPM	Saving preset memory	120
@GMU / @SMU	Start-up settings	120

■ Bitmap

Command	Function	Page
@GBM / @SBM	Bitmap output	121
@GBB / @SBB	Background color	122
@GBT / @SBT	Aspect ratio	123
@GZP / @SZP	Image position	124
@GBA / @SBA	Assigning input channel	125
@GPB / @SPB	Start-up bitmap output	126
@GBD / @SBD	Dividing memory area	127
@GBV	Memory area status	127
@GFZ / @SFZ	Freeze	128
@CAP	Output image capture	128

■ Overlay bitmap

Command	Function	Page
@GZM / @SZM	Overlay bitmap output	129
@GZO / @SZO	Image position	130
@GZT / @SZT	Transparency	131
@GBL / @SBL	Blending	132

■ Configuring MSD-S

Command	Function	Page
@GLS / @SLS	Front panel security lockout	133
@GLM / @SLM	Grouping front panel security lockout	133
@GBZ / @SBZ	Beep	134

■ Status

Command	Function	Page
@GSS	Input signal and sink device status	135
@GES	Viewing sink device EDID	139
@GHC	System status	140
@GIV	Device information	140



3.3 Details of commands

In this section, “MAIN” and “PinP” stand for main window and PinP window respectively that are displayed on the sink device.

Optional descriptions are indicated in “()”.

Descriptions in this chapter are based on the MSD-S72.

3.3.1 Error status









@ERR	Error status
Description	Response in case the command is not executed
Response	@ERR, error 
Parameter	error: Error status 1 = Erroneous format or value 2 = Undefined command or wrong format 3 = Currently cannot be used 4 = Not used. 5 = The command could not be executed, because the control command was not registered. 6 = The command could not be processed since another command was being executed. 7 = Automatic measurement of input timing failed. 8 = Loading EDID from the sink device failed. 9 = Not used. 10 = The control command was stopped according to the stop condition. 11 = The control command was stopped since the number of retries exceeded the set value of “RETRY”. 12 = The control command of PJLink was stopped since the password did not match. 13 = The image could not be captured since the image size to be captured exceeded the reserved memory size. 14 = Capturing input image failed.
Getting example	@IOS  @ERR,2  @IOS is sent. Command format error
Remarks	—









3.3.2 Power status

@GDS / @SDS		Power status
Getting	Command	@GDS ↵
	Response	@GDS, startup ↵
Setting	Command	@SDS, startup ↵
	Response	@SDS, startup ↵
Parameter		startup: Start-up status 0 = OFF (Standby), 1 = ON (Power on)
Getting example		@GDS ↵ @GDS,1 ↵
		Getting the start-up status ON
Setting example		@SDS,1 ↵ @SDS,1 ↵
		Setting the start-up status to ON Completed
Remarks		—

3.3.3 Selecting I/O channels

@GSW / @SSW		Switching video and audio channel simultaneously
Getting	Command	@GSW ↵
	Response	@GSW, video_main_1, audio_main_1, video_main_2, audio_main_2 ↵
Setting	Command	@SSW, input, window (, input, window) ↵
	Response	@SSW, input, window (, input, window) ↵
Parameter		video_main_1-2: Video input channel of the OUT1/OUT2 main window audio_main_1-2: Audio input channel of the OUT1/OUT2 main window 0 (OFF) [Default], 1 to 7 = IN1 to IN7
		input: Video and audio input channel 0 (OFF) [Default], 1 to 7 = IN1 to IN7
		window: Window 0 = All windows, 1 = OUT1 main window, 2 = OUT2 main window
Getting example		@GSW ↵ @GSW,2,2,1,1 ↵
		Getting the input channel Video input channel of the OUT1 main window : IN2 Audio input channel of the OUT1 main window : IN2 Video input channel of the OUT2 main window : IN1 Audio input channel of the OUT2 main window : IN1
Setting example		@SSW,1,0 ↵ @SSW,1,0 ↵
		Setting the input channel of all windows to IN1 Completed
Remarks		—

@GPW / @SPW		Switching video and audio channel simultaneously (PIP windows included)
Getting	Command	@GPW 
	Response	@GPW, video_main_1, audio_main_1, video_main_2, audio_main_2, video_pinp_1, audio_pinp_1, video_pinp_2, audio_pinp_2 
Setting	Command	@SPW, input, window (, input, window···) 
	Response	@SPW, input, window (, input, window···) 
Parameter		video_main_1-2 : Video input channel of the OUT1/OUT2 main window audio_main_1-2 : Audio input channel of the OUT1/OUT2 main window video_pinp_1-2 : Video input channel of the OUT1/OUT2 PinP window audio_pinp_1-2 : Audio input channel of the OUT1/OUT2 PinP window (Not used) 0 (OFF) [Default], 1 to 7 = IN1 to IN7
		input: Video and audio input channel 0 (OFF) [Default], 1 to 7 = IN1 to IN7
		window: Window 0 = All windows, 1 = OUT1 main window, 2 = OUT2 main window, 201 = OUT1 PinP window, 202 = OUT2 PinP window
Getting example		@GPW  @GPW,2,2,1,1,3,0,4,0 
		Getting the input channel Video input channel of the OUT1 main window : IN2 Audio input channel of the OUT1 main window : IN2 Video input channel of the OUT2 main window : IN1 Audio input channel of the OUT2 main window : IN1 Video input channel of the OUT1 PinP window : IN3 Video input channel of the OUT2 PinP window : IN4
Setting example		@SPW,1,0  @SPW,1,0 
		Setting the input channel of all windows to IN1 Completed
Remarks		—

@GSV / @SSV		Switching video channel
Getting	Command	@GSV 
	Response	@GSV, video_main_1, video_main_2 
Setting	Command	@SSV, input, window (, input, window) 
	Response	@SSV, input, window (, input, window) 
Parameter		<p>video_main_1-2 : Video input channel of the OUT1/OUT2 main window video_pinp_1-2 : Video input channel of the OUT1/OUT2 PinP window 0 = OFF [Default], 1 to 7 = IN1 to IN7</p> <p>input: Video input channel 0 = OFF [Default], 1 to 7 = IN1 to IN7</p> <p>window: Window 0 = All windows, 1 = OUT1 main window, 2 = OUT2 main window</p>
Getting example		<p>@GSV </p> <p>@GSV,2,1 </p> <p>Getting the video input channel OUT1 main window : IN2 OUT2 main window : IN1</p>
Setting example		<p>@SSV,1,0 </p> <p>@SSV,1,0 </p> <p>Setting the video input channel of all windows to IN1 Completed</p>
Remarks		—

@GSA / @SSA		Switching audio channel
Getting	Command	@GSA
	Response	@GSA, audio_main_1, audio_main_2
Setting	Command	@SSA, input, window (, input, window)
	Response	@SSA, input, window (, input, window)
Parameter		audio_main_1-2: Audio input channel of the OUT1/OUT2 main window 0 = OFF [Default], 1 to 7 = IN1 to IN7 input: Audio input channel 0 = OFF [Default], 1 to 7 = IN1 to IN7 window: Window 0 = All windows, 1 = OUT1 main window, 2 = OUT2 main window
Getting example		@GSA
		@GSA,1,2
		Getting the audio input channel OUT1 main window : IN1 OUT2 main window : IN2
Setting example		@SSA,1,1
		@SSA,1,1
		Setting the OUT1 audio input channel to IN1 Completed
Remarks	—	

@GPI / @SPI		Layout pattern
Getting	Command	@GPI
	Response	@GPI, pinp_1, pinp_2
Setting	Command	@SPI, output, pinp (, output, pinp)
	Response	@SPI, output, pinp (, output, pinp)
Parameter		output: Output channel 0 = All outputs, 1 = OUT1, 2 = OUT2 pinp_1-2 : OUT1/OUT2 layout pattern pinp : Layout pattern 0 = OFF [Default], 1 = PinP PATTERN1, 2 = PinP PATTERN2, 3 = PinP PATTERN3, 4 = PinP PATTERN4, 5 = PinP PATTERN5
Getting example		@GPI
		@GPI,2,4
		Getting the layout pattern OUT1 : PinP PATTERN2 OUT2 : PinP PATTERN4
Setting example		@SPI,1,0
		@SPI,1,0
		Setting the OUT1 layout pattern to OFF Completed
Remarks	—	

3.3.4 Output position, size, and masking

@GOT / @SOT		Output resolution																														
Getting	Command	@GOT ↵																														
	Response	@GOT, resolution_1, resolution_2 ↵																														
Setting	Command	@SOT, output, resolution, (, output, resolution) ↵																														
	Response	@SOT, output, resolution, (, output, resolution) ↵																														
Parameter		<p>output: Output channel 0 = All outputs, 1 = OUT1, 2 = OUT2</p> <p>resolution_1-2 : OUT1/OUT2 output resolution resolution : Output resolution</p> <table border="0"> <tr> <td>1 = VGA (640x480),</td> <td>3 = XGA (1024x768),</td> </tr> <tr> <td>4 = WXGA (1280x768),</td> <td>5 = WXGA (1280x800),</td> </tr> <tr> <td>6 = QuadVGA (1280x960),</td> <td>7 = SXGA (1280x1024),</td> </tr> <tr> <td>8 = WXGA (1360x768),</td> <td>9 = WXGA (1366x768),</td> </tr> <tr> <td>10 = SXGA+ (1400x1050),</td> <td>11 = WXGA+ (1440x900),</td> </tr> <tr> <td>12 = WXGA++ (1600x900),</td> <td>13 = UXGA (1600x1200),</td> </tr> <tr> <td>14 = WSXGA+ (1680x1050),</td> <td>15 = VESAHD (1920x1080),</td> </tr> <tr> <td>16 = WUXGA (1920x1200),</td> <td>17 = QWXGA (2048x1152),</td> </tr> <tr> <td>19 = 480p 59.94Hz,</td> <td>21 = 576p 50Hz,</td> </tr> <tr> <td>22 = 720p 50Hz,</td> <td>23 = 720p 59.94Hz,</td> </tr> <tr> <td>24 = 720p 60Hz,</td> <td>25 = 1080i 50Hz,</td> </tr> <tr> <td>26 = 1080i 59.94Hz,</td> <td>27 = 1080i 60Hz,</td> </tr> <tr> <td>28 = 1080p 50Hz,</td> <td>29 = 1080p 59.94Hz,</td> </tr> <tr> <td>30 = 1080p 60Hz,</td> <td>200 = AUTO-A [Default],</td> </tr> <tr> <td></td> <td>201 = AUTO-B</td> </tr> </table>	1 = VGA (640x480),	3 = XGA (1024x768),	4 = WXGA (1280x768),	5 = WXGA (1280x800),	6 = QuadVGA (1280x960),	7 = SXGA (1280x1024),	8 = WXGA (1360x768),	9 = WXGA (1366x768),	10 = SXGA+ (1400x1050),	11 = WXGA+ (1440x900),	12 = WXGA++ (1600x900),	13 = UXGA (1600x1200),	14 = WSXGA+ (1680x1050),	15 = VESAHD (1920x1080),	16 = WUXGA (1920x1200),	17 = QWXGA (2048x1152),	19 = 480p 59.94Hz,	21 = 576p 50Hz,	22 = 720p 50Hz,	23 = 720p 59.94Hz,	24 = 720p 60Hz,	25 = 1080i 50Hz,	26 = 1080i 59.94Hz,	27 = 1080i 60Hz,	28 = 1080p 50Hz,	29 = 1080p 59.94Hz,	30 = 1080p 60Hz,	200 = AUTO-A [Default],		201 = AUTO-B
1 = VGA (640x480),	3 = XGA (1024x768),																															
4 = WXGA (1280x768),	5 = WXGA (1280x800),																															
6 = QuadVGA (1280x960),	7 = SXGA (1280x1024),																															
8 = WXGA (1360x768),	9 = WXGA (1366x768),																															
10 = SXGA+ (1400x1050),	11 = WXGA+ (1440x900),																															
12 = WXGA++ (1600x900),	13 = UXGA (1600x1200),																															
14 = WSXGA+ (1680x1050),	15 = VESAHD (1920x1080),																															
16 = WUXGA (1920x1200),	17 = QWXGA (2048x1152),																															
19 = 480p 59.94Hz,	21 = 576p 50Hz,																															
22 = 720p 50Hz,	23 = 720p 59.94Hz,																															
24 = 720p 60Hz,	25 = 1080i 50Hz,																															
26 = 1080i 59.94Hz,	27 = 1080i 60Hz,																															
28 = 1080p 50Hz,	29 = 1080p 59.94Hz,																															
30 = 1080p 60Hz,	200 = AUTO-A [Default],																															
	201 = AUTO-B																															
Getting example	@GOT ↵																															
	@GOT,7,29 ↵	<p>Getting the output resolution</p> <p>OUT1 : SXGA</p> <p>OUT2 : 1080p 59.94Hz</p>																														
Setting example	@SOT,1,11 ↵																															
	@SOT,1,11 ↵	<p>Setting the OUT1 output resolution to WXGA+</p> <p>Completed</p>																														
Remarks	—																															

@GTD		Actual output resolution
Getting	Command	@GTD ↵
	Response	@GTD, resolution_1, resolution_2 ↵
Parameter	resolution_1-2: OUT1/OUT2 actual output resolution 1 = VGA (640x480), 2 = WXGA (1280x768), 3 = XGA (1024x768), 4 = WXGA (1280x800), 5 = WXGA (1280x960), 6 = QuadVGA (1280x960), 7 = SXGA (1280x1024), 8 = WXGA (1360x768), 9 = WXGA (1366x768), 10 = SXGA+ (1400x1050), 11 = WXGA+ (1440x900), 12 = WXGA++ (1600x900), 13 = UXGA (1600x1200), 14 = WSXGA+ (1680x1050), 15 = VESAHD (1920x1080), 16 = WUXGA (1920x1200), 17 = QWXGA (2048x1152), 19 = 480p 59.94Hz, 21 = 576p 50Hz, 22 = 720p 50Hz, 23 = 720p 59.94Hz, 24 = 720p 60Hz, 25 = 1080i 50Hz, 26 = 1080i 59.94Hz, 27 = 1080i 60Hz, 28 = 1080p 50Hz, 29 = 1080p 59.94Hz [Default], 30 = 1080p 60Hz	
Getting example	@GTD ↵	
	@GTD,29,24 ↵ Getting the actual output resolution OUT1 : 1080p 59.94Hz OUT2 : 720p 60Hz	
Remarks	The actual output resolution is returned. 【See: @GOT / @SOT Output resolution】	

@GUM / @SUM		Aspect ratio for window
Getting	Command	@GUM ↵
	Response	@GUM, aspect_main_1, aspect_main_2, aspect_pinp_1, aspect_pinp_2 ↵
Setting	Command	@SUM, window, aspect (, window, aspect···) ↵
	Response	@SUM, window, aspect (, window, aspect···) ↵
Parameter		window: Window 0 = All windows, 1 = OUT1 main window, 2 = OUT2 main window, 201 = OUT1 PinP window, 202 = OUT2 PinP window
		aspect_main_1-2 : Aspect ratio for the OUT1/OUT2 main window aspect_pinp_1-2 : Aspect ratio for the OUT1/OUT2 PinP window aspect : Aspect ratio for windows 0 = RESOLUTION [Default], 1 = 4:3, 2 = 5:4, 3 = 5:3, 4 = 16:9, 5 = 16:10
Getting example	@GUM ↵ @GUM,4,1,1,3 ↵	
	Getting the connected aspect ratio OUT1 main widow : 16:9 OUT2 main window : 4:3 OUT1 PinP window : 4:3 OUT2 PinP window : 5:3	
Setting example	@SUM,1,4 ↵ @SUM,1,4 ↵	
	Setting 16:9 aspect ratio to the OUT1 main window Completed	
Remarks	—	

@GOP / @SOP		Image position
Getting	Command	@GOP ↵
	Response	@GOP, h_position_main_1, v_position_main_1, h_position_main_2, v_position_main_2, h_position_pinp_1, v_position_pinp_1, h_position_pinp_2, v_position_pinp_2 ↵
Setting	Command	@SOP, window, h_position, v_position (, window, h_position, v_position···) ↵
	Response	@SOP, window, h_position, v_position (, window, h_position, v_position···) ↵
Parameter		<p>window: Window 0 = All windows, 1 = OUT1 main window, 2 = OUT2 main window, 201 = OUT1 PinP window, 202 = OUT2 PinP window</p> <p>h_position_main_1-2: Horizontal image position of the OUT1/OUT2 main window [pixel] h_position_pinp_1-2 : Horizontal image position of the OUT1/OUT2 PinP window [pixel] h_position : Horizontal image position [pixel] -Horizontal output image size to +Horizontal output resolution [by 1 pixel] [Default] See the table below.</p> <p>v_position_main_1-2 : Vertical image position of the OUT1/OUT2 main window [line] v_position_pinp_1-2 : Vertical image position of the OUT1/OUT2 PinP window [line] v_position : Vertical image position [line] -Vertical output image size to +Vertical output resolution [by 1 line] [Default] See the table below.</p>
Getting example		<p>@GOP ↵ @GOP,0,0,1440,0,0,0,30,30 ↵</p> <p>Getting the output image position (Horizontal, Vertical) OUT1 main window : (0, 0) OUT2 main window : (1440, 0) OUT1 PinP window : (0, 0) OUT2 PinP window : (30, 30)</p>
Setting example		<p>@SOP,1,5,20 ↵ @SOP,1,5,20 ↵</p> <p>Changing the horizontal and vertical image positions of the OUT1 main window to 5 and 20, respectively Completed</p>
Remarks		If “@GPI / @SPI Layout pattern” is disabled, PinP window cannot be set and “0” is returned for “@GOP”.

[Table 3.1] Default image position (at 1080p)

Pattern	Main (Horizontal/Vertical)	PinP (Horizontal/Vertical)
—	0/0	—(N/A)
P1	0/0	80/45
P2	0/0	1360/45
P3	0/0	80/765
P4	0/0	1360/765
P5	0/270	960/270

@GOS / @SOS		Image size
Getting	Command	@GOS ↵
	Response	@GOS, h_size_main_1, v_size_main_1, h_size_main_2, v_size_main_2, h_size_pinp_1, v_size_pinp_1, h_size_pinp_2, v_size_pinp_2 ↵
Setting	Command	@SOS, window, h_size, v_size (, window, h_size, v_size···) ↵
	Response	@SOS, window, h_size, v_size (, window, h_size, v_size···) ↵
Parameter		<p>window: Window</p> <p>0 = All windows, 1 = OUT1 main window, 2 = OUT2 main window, 201 = OUT1 PinP window, 202 = OUT2 PinP window</p> <p>h_size_main_1-2 : Horizontal image size of the OUT1/OUT2 main window [pixel] h_size_pinp_1-2 : Horizontal image size of the OUT1/OUT2 PinP window [pixel] h_size : Horizontal image size [pixel] Horizontal output resolution ÷4 to Horizontal output resolution ×4 [by 1 pixel] [Default] See the table below.</p> <p>v_size_main_1-2 : Vertical image size of the OUT1/OUT2 main window [line] v_size_pinp_1-2 : Vertical image size of the OUT1/OUT2 PinP window [line] v_size : Vertical image size [line] Vertical output resolution ÷4 to Vertical output resolution ×4 [by 1 line] [Default] See the table below.</p>
Getting example		<p>@GOS ↵</p> <p>@GOS,1920,1080,480,270,960,540,960,540 ↵</p> <p>Getting the output image size</p> <p>OUT1 main window : 1920x1080</p> <p>OUT2 main window : 480x270</p> <p>OUT1 PinP window : 960x540</p> <p>OUT2 PinP window : 960x540</p>
Setting example		<p>@SOS,2,1920,1080 ↵</p> <p>@SOS,2,1920,1080 ↵</p> <p>Changing the image position of the OUT2 main window to 1920x1080</p> <p>Completed</p>
Remarks		If "@GPI / @SPI Layout pattern" is disabled, PinP window cannot be set and "0" is returned for "@GOP".

[Table 3.2] Default image size (at 1080p)

Pattern	Main (Horizontal/Vertical)	PinP (Horizontal/Vertical)
—	1920/1080	—(N/A)
P1	1920/1080	480/270
P2	1920/1080	480/270
P3	1920/1080	480/270
P4	1920/1080	480/270
P5	960/540	960/540

@GOM / @SOM		Cropping
Getting	Command	@GOM, window ↵
	Response	@GOM, window, left, right, top, bottom ↵
Setting	Command	@SOM, window, left, right, top, bottom ↵
	Response	@SOM, window, left, right, top, bottom ↵
Parameter	window: Window 1 = OUT1 main window, 2 = OUT2 main window, 201 = OUT1 PinP window, 202 = OUT2 PinP window	
	left: Left side cropping Horizontal output image position (0 or more) to Right side cropping [by 1 pixel] [Default] See the table below.	
	right: Right side cropping Left side cropping to Horizontal output image position + Horizontal output image size (Horizontal output resolution or less) [by 1 pixel] [Default] See the table below.	
	top: Top side cropping Vertical output image position (0 or more) to Bottom side cropping [by 1 line] [Default] See the table below.	
	bottom: Bottom side cropping Top side cropping to Vertical output image position + Vertical output image size (Vertical output resolution or less) [by 1 line] [Default] See the table below.	
Getting example	@GOM,1 ↵	
	@GOM,1,0,1920,0,1080 ↵	
	Getting the output cropping of the OUT1 main window Left side: 0, Right side: 1920, Top side: 0, Bottom side: 1080	
Setting example	@SOM,1,0,1920,0,1080 ↵	
	@SOM,1,0,1920,0,1080 ↵	
	Changing the output cropping of the OUT1 main window to 0 for left side, 1920 for right side, top side for 0, and 1080 for bottom side Completed	
Remarks	If "@GPI / @SPI Layout pattern" is disabled, PinP window cannot be set and "0" is returned for "@GOP".	

[Table 3.3] Default cropping value (at 1080p)

Pattern	Main (Left/Right/Top/Bottom)	PinP (Left/Right/Top/Bottom)
—	0/1920/0/1080	— (N/A)
P1	0/1920/0/1080	80/560/45/315
P2	0/1920/0/1080	1360/1840/45/315
P3	0/1920/0/1080	80/560/765/1035
P4	0/1920/0/1080	1360/1840/765/1035
P5	0/960/270/810	960/1920/270/810

@GBC / @SBC		Background color
Getting	Command	@GBC, output ↵
	Response	@GBC, output, red, green, blue ↵
Setting	Command	@SBC, output, red, green, blue ↵
	Response	@SBC, output, red, green, blue ↵
Parameter		output: Output channel 1 = OUT1, 2 = OUT2 red : Background color (Red) green : Background color (Green) blue : Background color (Blue) 0 to 255 [Default] 0 (Black)
Getting example		@GBC,1 ↵ @GBC,1,128,128,128 ↵ Getting the background color of the OUT1 output image red : 128 green : 128 blue : 128 (Gray)
Setting example		@SBC,1,128,128,128 ↵ @SBC,1,128,128,128 ↵ Setting the background color of the OUT1 output video to 128 (Gray) for all RGB Completed
Remarks		—

@GTP / @STP		Test pattern
Getting	Command	@GTP ↵
	Response	@GTP, pattern_1, scroll_1, pattern_2, scroll_2 ↵
Setting	Command	@STP, output, pattern, scroll (, output, pattern, scroll) ↵
	Response	@STP, output, pattern, scroll (, output, pattern, scroll) ↵
Parameter		<p>output: Output channel 1 = OUT1, 2 = OUT2</p> <p>pattern_1-2: OUT1/OUT2 test pattern pattern : Test pattern 0 = OFF [Default], 1 = V-COLOR BAR, 2 = H-COLOR BAR, 3 = V-GRAY SCALE, 4 = H-GRAY SCALE, 5 = VERTICAL RAMP, 6 = HORIZONTAL RAMP, 7 = 100% WHITE RASTER, 8 = 50% WHITE RASTER, 9 = RED RASTER, 10 = GREEN RASTER, 11 = BLUE RASTER, 12 = CROSS HATCH, 13 = OUTPUT FRAME, 14 = VERTICAL STRIPE, 15 = HORIZONTAL STRIPE, 16 = VERTICAL ZEBRA, 17 = HORIZONTAL ZEBRA</p> <p>Test pattern numbers 1 to 6, 16 and 17 can be scrolled.</p> <p>scroll_1-2: OUT1/OUT2 scrolling scroll : Scrolling 0 = OFF [Default], 1 to 10 = 3 pixels/1 frame to 30 pixels/1 frame</p> <p>The number of pixels to be scrolled per frame = The set value ×3</p>
Getting example		<p>@GTP ↵</p> <p>@GTP,3,1,0,0 ↵</p> <p>Getting the output test pattern OUT1: V-GRAY SCALE at 3 pixels/frame scrolling OUT2: Not outputting test pattern</p>
Setting example		<p>@STP,1,1,0 ↵</p> <p>@STP,1,1,0 ↵</p> <p>Setting OUT1 to display V-COLOR BAR without scrolling Completed</p>
Remarks		—

@OAS		Image Initialization
Setting	Command	@OAS, window ↵
	Response	@OAS, window ↵
Parameter		window: Window 0 = All windows, 1 = OUT1 main window, 2 = OUT2 main window, 201 = OUT1 PinP window, 202 = OUT2 PinP window
Setting example		@OAS,0 ↵ @OAS,0 ↵
		Initializing the following settings of all output channels: - @GOP / @SOP Image position - @GOS / @SOS Image size - @GOM / @SOM Cropping Completed
Remarks		Initializing the current PinP PATTEN <div style="text-align: right;">【See: @GPI / @SPI Layout pattern】</div>

3.3.5 Output

@GVO / @SVO		Output signal
Getting	Command	@GVO ↵
	Response	@GVO, signal_1A, signal_1B, signal_2A, signal_2B ↵
Setting	Command	@SVO, output, signal (, output, signal···) ↵
	Response	@SVO, output, signal (, output, signal···) ↵
Parameter		<p>output: Output connector 0 = All outputs, 1 = HDMI OUT1A, 2 = HDBT OUT1B, 3 = HDMI OUT2A, 4 = HDBT OUT2B</p> <p>signal_1A : Video output of the HDMI OUT1A signal_1B : Video output of the HDBT OUT1B signal_2A : Video output of the HDMI OUT2A signal_2B : Video output of the HDBT OUT2B signal : Video output 0 = Outputs black, 1 = Outputs selected input signal [Default], 2 = Not outputting sync signal or power</p>
Getting example		@GVO ↵ @GVO,0,1,1,1 ↵
		Getting the output signal HDMI OUT1A : Black HDBT OUT1B : Selected input signal HDMI OUT2A : Selected input signal HDBT OUT2B : Selected input signal
Setting example		@SVO,1,1 ↵ @SVO,1,1 ↵
		HDMI OUT1A outputs selected input signal. Completed
Remarks		If stopping outputting synchronous signal, the sink device may be in standby status.

@GBO / @SBO		Output video for when no input video
Getting	Command	@GBO ↵
	Response	@GBO, video_main_1, video_main_2, video_pinp_1, video_pinp_2 ↵
Setting	Command	@SBO, window, video (, window, video···) ↵
	Response	@SBO, window, video (, window, video···) ↵
Parameter		<p>window: Window</p> <p>0 = All windows, 1 = OUT1 main window, 2 = OUT2 main window, 201 = OUT1 PinP window, 202 = OUT2 PinP window</p> <p>video_main_1-2: Output video for when no input video of the OUT1/OUT2 main window</p> <p>video_pinp_1-2 : Output video for when no input video of the OUT1/OUT2 PinP window</p> <p>video : Output video for when no input video</p> <p>0 = Black, 1 = Blue [Default], 2 = Background color, 3 = BITMAP 1, 4 = BITMAP 2, 5 = BITMAP 3, 6 = BITMAP 4, 7 = Not outputting sync signal or power</p> <p>For PinP, values other than “2” and “7” can be set. BITMAP numbers that is saved as a BITMAP can be set.</p>
Getting example		@GBO ↵ @GBO,1,2,0,1 ↵
		Getting the output video for when no input video OUT1 main window : Blue OUT2 main window : Background color OUT1 PinP window : Black OUT2 PinP window : Blue
Setting example		@SBO,1,1 ↵ @SBO,1,1 ↵
		Setting the OUT1 main window to output blue when no input video Completed
Remarks		If stopping outputting synchronous signal, the sink device may be in standby status.

@GEN / @SEN		HDCP output
Getting	Command	@GEN ↵
	Response	@GEN, hdcp_1A, hdcp_1B, hdcp_2A, hdcp_2B ↵
Setting	Command	@SEN, output, hdcp (, output, hdcp···) ↵
	Response	@SEN, output, hdcp (, output, hdcp···) ↵
Parameter		<p>output: Output connector 0 = All outputs, 1 = HDMI OUT1A, 2 = HDBT OUT1B, 3 = HDMI OUT2A, 4 = HDBT OUT2B</p> <p>hdcp_1A : HDCP output of the HDMI OUT1A hdcp_1B : HDCP output of the HDBT OUT1B hdcp_2A : HDCP output of the HDMI OUT2A hdcp_2B : HDCP output of the HDBT OUT2B hdcp : HDCP output 0 = HDCP is encrypted only if input signal is with HDCP, 1 = HDCP is always encrypted. [Default], 2 = HDCP is not encrypted.</p>
Getting example		@GEN ↵ @GEN,0,1,1,1 ↵
		Getting the HDCP output HDMI OUT1A : HDCP is encrypted only if input signal is with HDCP. HDBT OUT1B : HDCP is always encrypted. HDMI OUT2A : HDCP is always encrypted. HDBT OUT2B : HDCP is always encrypted.
Setting example		@SEN,1,1 ↵ @SEN,1,1 ↵
		Setting HDMI OUT1A to "1" (HDCP is always encrypted.) Completed
Remarks		—









@GHR / @SHR		HDCP retries
Getting	Command	@GHR
	Response	@GHR, retry_1A, retry_1B, retry_2A, retry_2B
Setting	Command	@SHR, output, retry (, output, retry···)
	Response	@SHR, output, retry (, output, retry···)
Parameter		<p>output: Output connector 0 = All outputs, 1 = HDMI OUT1A, 2 = HDBT OUT1B, 3 = HDMI OUT2A, 4 = HDBT OUT2B</p> <p>retry_1A : The number of retries for HDMI OUT1A retry_1B : The number of retries for HDBT OUT1B retry_2A : The number of retries for HDMI OUT2A retry_2B : The number of retries for HDBT OUT2B retry : The number of retries -1 = Retries until succeed [Default], 0 = Not retry, 1 to 100 = Retry for the desired number of retries</p>
Getting example		<p>@GHR </p> <p>@GHR,10,-1,-1,-1 </p> <p>Getting the number of HDCP retries HDMI OUT1A : Retry up to 10 times HDBT OUT1B : Continue to retry until succeed. HDMI OUT2A : Continue to retry until succeed. HDBT OUT2B : Continue to retry until succeed.</p>
Setting example		<p>@SHR,3,10 </p> <p>@SHR,3,10 </p> <p>Setting HDMI OUT2A to retry up to 10 times Completed</p>
Remarks		—

@HAU		HDCP re-encryption
Setting	Command	@HAU, output (, output···)
	Response	@HAU, output (, output···)
Parameter		<p>output: Output connector 0 = All outputs, 1 = HDMI OUT1A, 2 = HDBT OUT1B, 3 = HDMI OUT2A, 4 = HDBT OUT2B</p>
Setting example		<p>@HAU,1 </p> <p>@HAU,1 </p> <p>Setting HDMI OUT1A to re-encrypt HDCP Completed</p>
Remarks		—

@GEQ / @SEQ		Output equalizer
Getting	Command	@GEQ ↵
	Response	@GEQ, eq_1A, eq_2A ↵
Setting	Command	@SEQ, output, eq (, output, eq) ↵
	Response	@SEQ, output, eq (, output, eq) ↵
Parameter		output: Output connector 0 = All HDMI outputs, 1 = HDMI OUT1A, 2 = HDMI OUT2A eq_1A: Output equalizer of HDMI OUT1A eq_2A: Output equalizer of HDMI OUT2A eq : Output equalizer 0 = OFF [Default], 1 = LOW, 2 = MIDDLE, 3 = HIGH
Getting example		@GEQ ↵ @GEQ,0,1 ↵
		Getting the output equalizer HDMI OUT1A : OFF HDMI OUT2A : LOW
Setting example		@SEQ,1,0 ↵ @SEQ,1,0 ↵
		Setting the output equalizer of HDMI OUT1A to OFF Completed
Remarks		This command is for HDMI output only.

@GDM / @SDM		Output format
Getting	Command	@GDM ↵
	Response	@GDM, format_1A, format_1B, format_2A, format_2B ↵
Setting	Command	@SDM, output, format (, output, format···) ↵
	Response	@SDM, output, format (, output, format···) ↵
Parameter		<p>output: Output connector 0 = All outputs, 1 = HDMI OUT1A, 2 = HDBT OUT1B, 3 = HDMI OUT2A, 4 = HDBT OUT2B</p> <p>format_1A : Output format of HDMI OUT1A format_1B : Output format of HDBT OUT1B format_2A : Output format of HDMI OUT2A format_2B : Output format of HDBT OUT2B format : Output format 0 = DVI MODE, 1 = HDMI RGB MODE, 2 = HDMI YCbCr 4:2:2 MODE, 3 = HDMI YCbCr 4:4:4 MODE [Default]</p>
Getting example		<p>@GDM ↵ @GDM,3,0,3,3 ↵</p> <p>Getting the output format HDMI OUT1A : HDMI YCbCr 4:4:4 MODE HDBT OUT1B : DVI MODE HDMI OUT2A : HDMI YCbCr 4:4:4 MODE HDBT OUT2B : HDMI YCbCr 4:4:4 MODE</p>
Setting example		<p>@SDM,1,3 ↵ @SDM,1,3 ↵</p> <p>Setting the HDMI OUT1A format to HDMI YCbCr 4:4:4 MODE Completed</p>
Remarks		—

@GOA / @SOA		HDBaseT output long reach mode
Getting	Command	@GOA
	Response	@GOA, long_1B, long_2B
Setting	Command	@SOA, output, long (, output, long)
	Response	@SOA, output, long (, output, long)
Parameter		<p>output: Output connector 0 = All HDBaseT outputs, 1 = HDBT OUT1B, 2 = HDBT OUT2B</p> <p>long_1B: Long reach mode of HDBT OUT1B long_2B: Long reach mode of HDBT OUT2B long : Long reach mode 0 = OFF [Default], 1 = ON</p>
Getting example		@GOA @GOA,1,0
		Getting the HDBaseT output long reach mode HDBT OUT1B: ON HDBT OUT2B: OFF
Setting example		@SOA,1,1 @SOA,1,1
		Setting the long reach mode of HDBT OUT1B to ON Completed
Remarks		<p>This command is for HDBaseT output only. Long reach mode is for resolutions up to 1080p (24 bit) or dot clock 148 MHz. 【See: @GOT / @SOT Output resolution】</p>

@GFF / @SFF		Window transition effect
Getting	Command	@GFF 
	Response	@GFF, switching_main_1, switching_main_2, switching_pinp_1, switching_pinp_2 
Setting	Command	@SFF, window, switching (, window, switching···) 
	Response	@SFF, window, switching (, window, switching···) 
Parameter		<p>window: Window</p> <p>0 = All windows, 1 = OUT1 main window, 2 = OUT2 main window, 201 = OUT1 PinP window, 202 = OUT2 PinP window</p> <p>switching_main_1-2 : Window transition effect of the OUT1/OUT2 main window switching_pinp_1-2 : Window transition effect of the OUT1/OUT2 PinP window switching : Window transition effect</p> <p>0 = CUT, 1 = FADE OUT-IN, 2 = FREEZE→FADE OUT-IN [Default]</p>
Getting example		@GFF 
		@GFF,0,1,2,2 
		<p>Getting the video input channel switching effect</p> <p>OUT1 main window : CUT</p> <p>OUT2 main window : FADE OUT-IN</p> <p>OUT1 PinP window : FREEZE→FADE OUT-IN</p> <p>OUT2 PinP window : FREEZE→FADE OUT-IN</p>
Setting example		@SFF,1,1 
		@SFF,1,1 
		<p>Setting the OUT1 main window to FADE OUT-IN</p> <p>Completed</p>
Remarks	—	

@GFT / @SFT		Window transition speed
Getting	Command	@GFT ↵
	Response	@GFT, time_main_1, time_main_2, time_pinp_1, time_pinp_2 ↵
Setting	Command	@SFT, window, time (, window, time···) ↵
	Response	@SFT, window, time (, window, time···) ↵
Parameter		window: Window 0 = All windows, 1 = OUT1 main window, 2 = OUT2 main window, 201 = OUT1 PinP window, 202 = OUT2 PinP window
		time_main_1-2 : Switching speed of the OUT1/OUT2 main window [ms.] time_pinp_1-2 : Switching speed of the OUT1/OUT2 PinP window [ms.] time : Switching speed [ms.] 100 to 2000 [Default] 350 Set the value by 10 ms. The last figure will be dropped.
Getting example		@GFT ↵ @GFT,400,1000,500,800 ↵
		Getting the switching speed OUT1 main window : 400 ms. OUT2 main window : 1000 ms. OUT1 PinP window : 500 ms. OUT2 PinP window : 8000 ms.
Setting example		@SFT,1,400 ↵ @SFT,1,400 ↵
		Setting the window transition speed of the OUT1 main window to 400 ms. Completed
Remarks		—

@GCE / @SCE		CEC connection
Getting	Command	@GCE ↵
	Response	@GCE, cec_1A, cec_1B, cec_2A, cec_2B ↵
Setting	Command	@SCE, output, cec (, output, cec···) ↵
	Response	@SCE, output, cec (, output, cec···) ↵
Parameter		<p>output: Output connector 0 = All outputs, 1 = HDMI OUT1A, 2 = HDBT OUT1B, 3 = HDMI OUT2A, 4 = HDBT OUT2B</p> <p>cec_1A : CEC connection of HDMI OUT1A cec_1B : CEC connection of HDBT OUT1B cec_2A : CEC connection of HDMI OUT2A cec_2B : CEC connection of HDBT OUT2B cec : CEC connection 0 = Not connected [Default], 1 = Selected video input channel, 2 = IN1, 3 = IN2, 4 = IN3, 5 = IN4, 6 = IN5</p>
Getting example		<p>@GCE ↵ @GCE,4,0,0,0 ↵</p> <p>Getting the CEC connection HDMI OUT1A : Connecting to IN3 HDBT OUT1B: Not connected HDMI OUT2A : Not connected HDBT OUT2B: Not connected</p>
Setting example		<p>@SCE,1,4 ↵ @SCE,1,4 ↵</p> <p>Setting the HDMI OUT1A CEC connection to IN3 Completed</p>
Remarks		—

3.3.6 Input position, size, and masking

@GAP / @SAP		Aspect ratio
Getting	Command	@GAP ↵
	Response	@GAP, aspect_1, aspect_2, aspect_3, aspect_4, aspect_5, aspect_6, aspect_7 ↵
Setting	Command	@SAP, input, aspect (, input, aspect···) ↵
	Response	@SAP, input, aspect (, input, aspect···) ↵
Parameter		input: Input channel 0 = All inputs, 1 to 7 = IN1 to IN7
		aspect_1-7 : IN1 to IN7 aspect ratio aspect : Aspect ratio 0 = AUTO-1 [Default], 1 = AUTO-2, 2 = 4:3, 3 = 16:9, 4 = 14:9, 5 = 16:9 LETTER BOX, 6 = 14:9 LETTER BOX, 7 = 4:3 SIDE PANEL, 8 = 14:9 SIDE PANEL, 9 = FULL, 10 = THROUGH
Getting example		@GAP ↵
		@GAP,0,0,2,0,0,0,0 ↵
		Getting the aspect ratio IN3 : 4:3 Other inputs : AUTO-1
Setting example		@SAP,7,2 ↵
		@SAP,7,2 ↵
		Setting the IN7 aspect ratio to 4:3 Completed
Remarks	—	

@GAR / @SAR		Aspect ratio control
Getting	Command	@GAR ↵
	Response	@GAR, mode_1, mode_2, mode_3, mode_4, mode_5, mode_6, mode_7 ↵
Setting	Command	@SAR, input, mode (, input, mode···) ↵
	Response	@SAR, input, mode (, input, mode···) ↵
Parameter		input: Input channel 0 = All inputs, 1 to 7 = IN1 to IN7 mode_1-7 : IN1 to IN7 aspect ratio control mode : Aspect ratio control 0 = Letter box/Side panel [Default], 1 = Side cut/Top bottom cut
Getting example	@GAR ↵ @GAR,0,0,1,0,0,0,0 ↵	
	Getting the aspect ratio control IN3 : Side cut/Top bottom cut Other inputs : Letter box/Side panel	
Setting example	@SAR,5,1 ↵ @SAR,5,1 ↵	
	Setting IN5 to Side cut/Top bottom cut Completed	
Remarks	—	

@GOV / @SOV		Overscan
Getting	Command	@GOV ↵
	Response	@GOV, overscan_1, overscan_2, overscan_3, overscan_4, overscan_5, overscan_6, overscan_7 ↵
Setting	Command	@SOV, input, overscan (, input, overscan···) ↵
	Response	@SOV, input, overscan (, input, overscan···) ↵
Parameter		input: Input channel 0 = All inputs, 1 to 7 = IN1 to IN7 overscan_1-7 : IN1 to IN7 overscan [%] overscan : Overscan [%] 100 to 115 [Default] SDTV : 105 HDTV/PC : 100
Getting example	@GOV ↵ @GOV,100,100,105,100,100,100,100 ↵	
	Getting the overscan IN3 : 105% Other inputs : 100%	
Setting example	@SOV,7,105 ↵ @SOV,7,105 ↵	
	Setting the IN7 overscan to 105% Completed	
Remarks	—	

@GNP / @SNP		Image position
Getting	Command	@GNP ↵
	Response	@GNP, h_position_1, v_position_1, h_position_2, v_position_2, h_position_3, v_position_3, h_position_4, v_position_4, h_position_5, v_position_5, h_position_6, v_position_6, h_position_7, v_position_7 ↵
Setting	Command	@SNP, input, h_position, v_position (, input, h_position, v_position···) ↵
	Response	@SNP, input, h_position, v_position (, input, h_position, v_position···) ↵
Parameter		<p>input: Input channel 0 = All inputs, 1 to 7 = IN1 to IN7</p> <p>h_position_1-7 : IN1 to IN7 horizontal image position [pixel] h_position : Horizontal image position [pixel] -Horizontal input image size to +Horizontal output resolution [by 1 pixel] [Default] 0</p> <p>v_position_1-7: IN1 to IN7 vertical image position [line] v_position : Vertical image position [line] -Vertical input image size to +Vertical output resolution [by 1 line] [Default] 0</p>
Getting example		<p>@GNP ↵</p> <p>@GNP,-50,20,0,0,0,0,0,0,0,0,0,0,0,0 ↵</p> <p>Getting the input image position</p> <p>IN1 : Horizontal image position is -50 Vertical image position is +20</p> <p>Other inputs : Horizontal and Vertical image positions are 0</p>
Setting example		<p>@SNP,1,-50,20 ↵</p> <p>@SNP,1,-50,20 ↵</p> <p>Setting the IN1 horizontal and vertical image positions are to -50 and +20, respectively</p> <p>Completed</p>
Remarks		—

@GNS / @SNS		Image size
Getting	Command	@GNS ↵
	Response	@GNS, h_size_1, v_size_1, h_size_2, v_size_2, h_size_3, v_size_3, h_size_4, v_size_4, h_size_5, v_size_5, h_size_6, v_size_6, h_size_7, v_size_7 ↵
Setting	Command	@SNS, input, h_size, v_size (, input, h_size, v_size...) ↵
	Response	@SNS, input, h_size, v_size (, input, h_size, v_size...) ↵
Parameter		<p>input : Input channel 0 = All inputs, 1 to 7 = IN1 to IN7</p> <p>h_size_1-7 : IN1 to IN7 horizontal image size [pixel] h_size : Horizontal image size [pixel] Horizontal output resolution ÷4 to Horizontal output resolution ×4 [by 1 pixel] [Default] Horizontal output resolution</p> <p>v_size_1-7 : IN1 to IN7 vertical image size [line] v_size : Vertical image size [line] Vertical output resolution ÷4 to Vertical output resolution ×4 [by 1 line] [Default] Vertical output resolution</p>
Getting example		<p>@GNS ↵</p> <p>@GNS,1925,1084,1920,1080,1920,1080,1920,1080,1920,1080,1920,1080,1920,1080 ↵</p> <p>Getting the input image size</p> <p>IN1 : Horizontal image size is 1925 Vertical image size is 1084</p> <p>Other inputs : Horizontal image size is 1920 Vertical image size is 1080</p>
Setting example		<p>@SNS,1,1925,1084 ↵</p> <p>@SNS,1,1925,1084 ↵</p> <p>Setting the IN1 horizontal and vertical input image size are 1925 and 1084, respectively</p> <p>Completed</p>
Remarks		—

@GNM / @SNM		Cropping
Getting	Command	@GNM, input ↵
	Response	@GNM, input, left, right, top, bottom ↵
Setting	Command	@SNM, input, left, right, top, bottom ↵
	Response	@SNM, input, left, right, top, bottom ↵
Parameter		<p>input: Input channel 1 to 7 = IN1 to IN7</p> <p>left: Left side cropping [pixel] Horizontal input image position to Right side cropping [by 1 pixel] [Default] 0</p> <p>right: Right side cropping [pixel] Left side cropping to Horizontal input image position + Horizontal input image Size [by 1 pixel] [Default] Horizontal input image size</p> <p>top: Top side cropping [line] Vertical input image position to Bottom side cropping [by 1 line] [Default] 0</p> <p>bottom: Bottom side cropping [line] Top side cropping to Vertical input image position + Vertical input image size [by 1 line] [Default] Vertical input image size</p>
Getting example		<p>@GNM,1 ↵</p> <p>@GNM,1,0,1920,0,1080 ↵</p> <p>Getting the IN1 input cropping Left side: 0, Right side: 1920, Top side: 0, Bottom side: 1080</p>
Setting example		<p>@SNM,1,0,1920,0,1080 ↵</p> <p>@SNM,1,0,1920,0,1080 ↵</p> <p>Changing the IN1 input cropping to 0 for left side, 1920 for right side, top side for 0, and 1080 for bottom side Completed</p>
Remarks		—

@IAS		Image initialization
Setting	Command	@IAS, input (, input···) ↵
	Response	@IAS, input (, input···) ↵
Parameter		<p>input: Input channel 0 = All inputs, 1 to 7 = IN1 to IN7</p>
Setting example		<p>@IAS,1 ↵</p> <p>@IAS,1 ↵</p> <p>Initializing the IN1 following settings: - @GAP / @SAP Aspect ratio - @GOV / @SOV Overscan - @GNP / @SNP Image position - @GNS / @SNS Image size - @GNM / @SNM Cropping Completed</p>
Remarks		—

3.3.7 Input

@GIN / @SIN		DVI input connector signal
Getting	Command	@GIN ↵
	Response	@GIN, signal_1, signal_2 ↵
Setting	Command	@SIN, input, signal (, input, signal) ↵
	Response	@SIN, input, signal (, input, signal) ↵
Parameter		input: Input channel MSD-S71/S72 : 0 = All inputs, 6 = IN6, 7 = IN7 MSD-S51/S52 : 0 = All inputs, 5 = IN5 signal_1 : DVI input connector signal IN6 (MSD-S71/S72) or IN5 (MSD-S51/S52) signal_2 : DVI input connector signal IN7 (MSD-S71/S72) signal : DVI input connector signal 0 = Analog signal, 1 = Digital signal [Default]
Getting example		@GIN ↵
		@GIN,0,0 ↵
		Getting the DVI input connector signal IN6 and IN7: Analog input signal
Setting example		@SIN,6,1 ↵
		@SIN,6,1 ↵
		Setting IN6 to digital input signal Completed
Remarks		—

@GDT / @SDT		No-signal input monitoring
Getting	Command	@GDT ↵
	Response	@GDT, time_1, time_2, time_3, time_4, time_5, time_6, time_7 ↵
Setting	Command	@SDT, input, time (, input, time···) ↵
	Response	@SDT, input, time (, input, time···) ↵
Parameter		<p>input: Input channel 0 = All digital inputs, 1 to 7 = IN1 to IN7</p> <p>time_1-7 : IN1 to IN7 no-signal input monitoring time time : No-signal input monitoring time 0 = OFF, 2000 to 15000 = 2 sec. to 15 sec. [Default] 10000 = 10 sec. -1 = Not available, DVI input connector is set to analog input (Only getting) Set the value by 100 ms. The two figures will be dropped.</p>
Getting example		<p>@GDT ↵</p> <p>@GDT,6000,10000,10000,4000,4000,4000,4000 ↵</p> <p>Getting the monitoring time of input video signal IN1 : 6000 ms. (6 seconds) IN2 and IN3 : 10000 ms. (10 seconds) IN4 to IN7 : 4000 ms. (4 seconds)</p>
Setting example		<p>@SDT,3,6000 ↵</p> <p>@SDT,3,6000 ↵</p> <p>Setting the IN3 monitoring time to 6000 ms. (6 seconds) Completed</p>
Remarks		<p>These commands are only for digital input. With DVI input connector signals, these commands are valid only if the connector is set to digital.</p> <p style="text-align: right;">【See: @GIN / @SIN DVI input connector signal】</p>

@GHE / @SHE		HDCP input
Getting	Command	@GHE
	Response	@GHE, hdcp_1, hdcp_2, hdcp_3, hdcp_4, hdcp_5, hdcp_6, hdcp_7
Setting	Command	@SHE, input, hdcp (, input, hdcp···)
	Response	@SHE, input, hdcp (, input, hdcp···)
Parameter		input: Input channel 0 = All digital inputs, 1 to 7 = IN1 to IN7 hdcp_1-7 : IN1 to IN7 HDCP input enabled/disabled hdcp : HDCP input enabled/disabled 0 = DISABLE, 1 = ENABLE [Default], -1 = Not available, DVI input connector is set to analog input (Only getting)
Getting example		@GHE @GHE,1,1,0,1,1,1,1 Getting HDCP input enabled/disabled IN3 : Disables HDCP input Other inputs : Enables HDCP input
Setting example		@SHE,1,0 @SHE,1,0 Setting the IN1 HDCP input to be disabled Completed
Remarks		These commands are only for digital input. With DVI input connectors, these commands are valid only if the connector is set to digital. <p style="text-align: right;">【See: @GIN / @SIN DVI input connector signal】</p>

@GIQ / @SIQ		Input equalizer
Getting	Command	@GIQ
	Response	@GIQ, eq_1, eq_2, eq_3, eq_4, eq_5
Setting	Command	@SIQ, input, eq (, input, eq···)
	Response	@SIQ, input, eq (, input, eq···)
Parameter		input: Input channel 0 = All HDMI input connectors, 1 to 5 = IN1 to IN5 eq_1-5 : IN1 to IN5 input equalizer eq : Input equalizer 0 = OFF, 1 = ON [Default]
Getting example		@GIQ @GIQ,0,1,1,1,1 Getting the input equalizer IN1 : OFF Other inputs : ON
Setting example		@SIQ,3,0 @SIQ,3,0 Disabling the IN3 input equalizer Completed
Remarks		This command is for HDMI input only.

@GAI / @SAI		Analog input signal parameters
Getting	Command	@GAI ↵
	Response	@GAI, type_1, type_2 ↵
Setting	Command	@SAI, input, type (, input, type) ↵
	Response	@SAI, input, type (, input, type) ↵
Parameter	input: Input channel MSD-S71/S72 : 0 = All analog inputs, 6 = IN6 (Analog), 7 = IN7 (Analog) MSD-S51/S52 : 0 = All analog inputs, 5 = IN5 (Analog)	
	type_1: Signal parameters IN6 (MSD-S71/S72) or IN5 (MSD-S51/S52)	
	type_2: Signal parameters IN7 (MSD-S71/S72)	
	Type : Signal parameters 0 = AUTO [Default], 1 = RGB, 2 = YPbPr, -1 = Not available, HDMI input connector is set to digital input (Only getting)	
Getting example	@GAI ↵ @GAI,2,0 ↵	
	Getting the analog input signal parameters IN6 : YPbPr IN7 : AUTO	
Setting example	@SAI,0,2 ↵ @SAI,0,2 ↵	
	Setting all analog input signal parameters to YPbPr Completed	
Remarks	These commands are only for analog input. With DVI input connector signals, these commands are valid only if the connector is set to analog. <p style="text-align: right;">【See: @GIN / @SIN DVI input connector signal】</p>	

@GID / @SID		Automatic detection of video input interruption
Getting	Command	@GID ↵
	Response	@GID, detect_1, detect_2, detect_3, detect_4, detect_5, detect_6, detect_7 ↵
Setting	Command	@SID, input, detect (, input, detect···) ↵
	Response	@SID, input, detect (, input, detect···) ↵
Parameter		input: Input channel 0 = All inputs, 1 to 7 = IN1 to IN7 detect_1-7 : IN1 to IN7 automatic detection detect : Automatic detection 0 = OFF, 1 = ON [Default]
Getting example		@GID ↵ @GID,1,1,1,1,1,0,1 ↵ Getting the automatic detection of video input interruption IN6 : If input video signal is interrupted, the video output is not turned off instantly. Other inputs : OFF
Setting example		@SID,2,0 ↵ @SID,2,0 ↵ Setting the IN2 automatic detection to OFF ("0") Completed
Remarks		

@GFX / @SFX		Fixing settings for each input signal
Getting	Command	@GFX, input
	Response	@GFX, input, mode (, aspect, analog, audio)
Setting	Command	@SFX, input, mode (, aspect, analog, audio)
	Response	@SFX, input, mode (, aspect, analog, audio)
Parameter		<p>input: Input channel 1 to 7 = IN1 to IN7</p> <p>mode: Setting mode 0 = SELECTED [Default], 1 = ALL FIXED</p> <p>Only is "0" (SELECTED) is set for the setting mode, the following parameters can be set:</p> <p>aspect : Aspect ratio 0 = OFF [Default], 1 = ON (FIXED)</p> <p>analog : Analog input signal parameters (For digital input, select "0") 0 = OFF, 1 = ON (FIXED) [Default]</p> <p>audio :Audio input level (For analog input, select "0") 0 = OFF, 1 = ON (FIXED) [Default]</p>
Getting example		<p>@GFX,6 </p> <p>@GFX,6,0,1,0,0 </p> <p>Getting the IN6 fixed setting for each input signal. (If DVI input connector is set to analog)</p> <p>Aspect ratio : Current setting</p> <p>Analog input signal parameters : Setting of each input signal</p> <p>Audio input level : OFF</p>
Setting example		<p>@SFX,2,1 </p> <p>@SFX,2,1 </p> <p>IN2: Fixing settings for each input to the current settings</p> <p>Completed</p>
Remarks		<p>When digital input channel is acquired, "0" is returned for the parameter of analog input signal parameters. ("0" is an invalid value.)</p> <p>When analog input channel is acquired, "0" is returned for the parameter of audio input level. ("0" is an invalid value.)</p>

3.3.8 Input timing

@AIS / @AIT		Automatic measurement
Setting	Description	Automatic measurement of the start position and active area
	Command	@AIS, input ↵
	Response	@AIS, input ↵
Setting	Description	Auto measurement taking into account aspect ratio
	Command	@AIT, input (, mode) ↵
	Response	@AIT, input (, mode) ↵
Parameter	input: Input channel MSD-S71/S72 : 6 = IN6 (Analog), 7 = IN7 (Analog) MSD-S51/S52 : 5 = IN5 (Analog)	
	mode: Measurement mode -1 = NEXT ASPECT, 0 = 4:3, 1 = 5:4, 2 = 5:3, 3 = 16:9, 4 = 16:10 If you select "NEXT ASPECT", the next aspect ratio will be selected in order every time the automatic measurement is executed. If you do not set any mode parameter, "NEXT ASPECT" mode will be applied.	
Setting example	@AIS,6 ↵ @AIS,6 ↵	
	Enabling the IN6 automatic measurement of the start position and active area Completed	
Setting example	@AIT,6,0 ↵ @AIT,6,0 ↵	
	Enabling the IN6 automatic measurement of input timing setting at 4:3 Completed	
Setting example	@AIS,6 ↵ @ERR,7 ↵	
	If the automatic measurement fails, an error is returned.	
Remarks	These commands are only for analog input. These commands are valid only if the DVI input connector signal is set to analog and analog RGB/analog YPbPr signal is input. 【See: @GIN / @SIN DVI input connector signal】	

@GHT / @SHT		The total number of horizontal pixels
Getting	Command	@GHT ↵
	Response	@GHT, h_total_1, h_total_2, h_total_3, h_total_4, h_total_5, h_total_6, h_total_7 ↵
Setting	Command	@SHT, input, h_total ↵
	Response	@SHT, input, h_total ↵
Parameter		<p>input: Input channel MSD-S71/S72 : 0 = All analog inputs, 6 = IN6 (Analog), 7 = IN7 (Analog) MSD-S51/S52 : 0 = All analog inputs, 5 = IN5 (Analog)</p> <p>h_total_1-7 : The total number of horizontal pixels of IN1 to IN7 h_total : The total number of horizontal pixels 400 to 4125 (The sampling clock is within the range of 13 MHz to 165 MHz for interlace signal; 13 MHz to 82.5 MHz for non-interlace signal) [Default] Depends on input signal</p>
Getting example		@GHT ↵ @GHT,2200,2200,0,2640,1344,1792,0 ↵
		Getting the total number of horizontal pixels "0" is returned to channels without input signal.
Setting example		@SHT,6,1344 ↵ @SHT,6,1344 ↵
		Setting the IN6 total number of horizontal pixels to "1344" Completed
Setting example		@SHT,6,1344 ↵ @ERR,3 ↵
		An error is returned because analog RGB signal or analog YPbPr signal is not input.
Remarks		Getting command acquires all channels' statuses. Setting commands are valid only if the DVI input connector signal is set to analog and analog RGB/analog YPbPr signal is input. 【See: @GIN / @SIN DVI input connector signal】

@GHS / @SHS		Horizontal start position
Getting	Command	@GHS ↵
	Response	@GHS, h_start_1, h_start_2, h_start_3, h_start_4, h_start_5, h_start_6, h_start_7 ↵
Setting	Command	@SHS, input, h_start ↵
	Response	@SHS, input, h_start ↵
Parameter		<p>input: Input channel 0 = All inputs, 1 to 7 = IN1 to IN7</p> <p>h_start_1-7: IN1 to IN7 horizontal start position [pixel] h_start : Horizontal start position [pixel] 64 to 2900 (The total number of horizontal pixels - Horizontal active area or less) [Default] Depends on input signal</p>
Getting example		<p>@GHS ↵</p> <p>@GHS,192,192,496,0,296,0,378 ↵</p> <p>Getting the horizontal start position "0" is returned to channels without input signal.</p>
Setting example		<p>@SHS,5,296 ↵</p> <p>@SHS,5,296 ↵</p> <p>Setting the IN5 horizontal start position to "296" Completed</p>
Setting example		<p>@SHS,6,296 ↵</p> <p>@ERR,3 ↵</p> <p>An error is returned if no signal is input.</p>
Remarks		Setting command is valid only if signal is input.

@GHD / @SHD		Horizontal active area
Getting	Command	@GHD ↵
	Response	@GHD, h_disp_1, h_disp_2, h_disp_3, h_disp_4, h_disp_5, h_disp_6, h_disp_7 ↵
Setting	Command	@SHD, input, h_disp ↵
	Response	@SHD, input, h_disp ↵
Parameter		input: Input channel 0 = All inputs, 1 to 7 = IN1 to IN7 h_disp_1-7 : IN1 to IN7 horizontal active area [pixel] h_disp : Horizontal active area [pixel] 64 to 2900 (The total number of horizontal pixels - 64 or less) [Default] Depends on input signal
Getting example		@GHD ↵ @GHD,1920,1920,0,1920,1024,1360,0 ↵ Getting the horizontal active area "0" is returned to channels without input signal.
Setting example		@SHD,5,1024 ↵ @SHD,5,1024 ↵ Setting the IN5 horizontal active area to "1024" Completed
Setting example		@SHD,6,1024 ↵ @ERR,3 ↵ An error is returned if no signal is input.
Remarks		Setting command is valid only if signal is input.

@GVS / @SVS		Vertical start position
Getting	Command	@GVS ↵
	Response	@GVS, v_start_1, v_start_2, v_start_3, v_start_4, v_start_5, v_start_6, v_start_7 ↵
Setting	Command	@SVS, input, v_start ↵
	Response	@SVS, input, v_start ↵
Parameter		input: Input channel 0 = All inputs, 1 to 7 = IN1 to IN7 v_start_1-7: IN1 to IN7 vertical start position [line] v_start : Vertical start position [line] 10 to 2048 (The total number of vertical lines - Vertical active area or less) [Default] Depends on input signal
Getting example		@GVS ↵ @GVS,40,0,40,40,35,0,24 ↵ Getting the vertical start position "0" is returned to channels without input signal.
Setting example		@SVS,5,35 ↵ @SVS,5,35 ↵ Setting the IN5 vertical start position to "35" Completed
Setting example		@SVS,6,35 ↵ @ERR,3 ↵ An error is returned if no signal is input.
Remarks		Setting command is valid only if signal is input.

@GVD / @SVD		Vertical active area
Getting	Command	@GVD ↵
	Response	@GVD, v_disp_1, v_disp_2, v_disp_3, v_disp_4, v_disp_5, v_disp_6, v_disp_7 ↵
Setting	Command	@SVD, input, v_disp ↵
	Response	@SVD, input, v_disp ↵
Parameter		input: Input channel 0 = All inputs, 1 to 7 = IN1 to IN7 v_disp_1-7 : IN1 to IN7 vertical active area [line] v_disp : Vertical active area [line] 10 to 2048 (The total number of vertical lines - 10 or less) [Default] Depends on input signal
Getting example		@GVD ↵ @GVD,0,1080,1080,900,768,0,900 ↵ Getting the vertical active area "0" is returned to channels without input signal.
Setting example		@SVD,5,768 ↵ @SVD,5,768 ↵ Setting the IN5 vertical active area to "768" Completed
Setting example		@SVD,5,768 ↵ @ERR,3 ↵ An error is returned if no signal is input.
Remarks		Setting command is valid only if signal is input.

@GIS / @SIS		Automatic measurement of start position
Getting	Command	@GIS ↵
	Response	@GIS, mode_1, mode_2 ↵
Setting	Command	@SIS, input, mode (, input, mode) ↵
	Response	@SIS, input, mode (, input, mode) ↵
Parameter		input: Input channel MSD-S71/S72 : 0 = All analog inputs, 6 = IN6 (Analog), 7 = IN7 (Analog) MSD-S51/S52 : 0 = All analog inputs, 5 = IN5 (Analog)
		mode_1: Automatic measurement IN6 (MSD-S71/S72) or IN5 (MSD-S51/S52) mode_2: Automatic measurement IN7 (MSD-S71/S72) mode : Automatic measurement 0 = Not measuring all input signal from the input automatically, 1 = Not measuring the current input signal automatically, 2 = Measuring the current input signal automatically [Default], -1 = Not available, HDMI input connector is set to digital input (Only getting)
Getting example		@GIS ↵
		@GIS,0,2 ↵
		Getting the automatic measurement of start position IN6 : Not measured automatically IN7 : Measured automatically
Setting example		@SIS,6,1 ↵
		@SIS,6,1 ↵
		Setting the signal that is currently input from IN6 to "1" (Not measuring the current input signal automatically) Completed
Remarks		These commands are only for analog input. With DVI input connector signals, these commands are valid only if the connector is set to analog. <p style="text-align: right;">【See: @GIN / @SIN DVI input connector signal】</p>

@GSM / @SSM		Automatic setting of input timing
Getting	Command	@GSM ↵
	Response	@GSM, measure ↵
Setting	Command	@SSM, measure ↵
	Response	@SSM, measure ↵
Parameter		measure: Automatic measurement 0 = Not execute, 1 = Execute [Default]
Getting example		@GSM ↵
		@GSM,1 ↵
		Getting the mode of input timing automatic setting Execute
Setting example		@SSM,1 ↵
		@SSM,1 ↵
		Setting the automatic setting of input timing to execute Completed
Remarks		—

@RTT		Initializing digital input timing/Recalling analog input timing
Setting	Command	@RTT, input (, model) ↵
	Response	@RTT, input (, model) ↵
Parameter		input: Input channel 1 to 7 = IN1 to IN7
		model: Device table *Only for analog input 1 to 99 (Registered device data), 100 to 100+n (Preset device data. "n" varies depending on analog input signal)
Setting example		@RTT,1 ↵ @RTT,1 ↵
		Initializing the IN1 input timing to the values detected automatically Completed
Setting example		@RTT,6,2 ↵ @RTT,6,2 ↵
		Setting the IN6 input timing to the values saved in the device table 2 Completed
Remarks		This command is valid only if signal is input. For analog input, this command is valid only if the device data of input signal is registered.

@STT		Saving analog input timing
Setting	Command	@STT, input, model (, name) ↵
	Response	@STT, input, model (, name) ↵
Parameter	input: Input channel MSD-S71/S72 : 6 = IN6 (Analog), 7 = IN7 (Analog) MSD-S51/S52 : 5 = IN5 (Analog)	
	model: Device table 1 to 99	
	name: Device table name Up to 14 characters from 20 to 7D of ASCII code If you skip this parameter ("name"), only input timing settings are saved without changing its name. However, if no device table name is currently saved, the resolution is saved automatically as the device table name.	
Setting example	@STT,6,2 ↵ @STT,6,2 ↵	
	Saving the IN6 input timing in device table 2 without editing the device table name Completed	
Setting example	@STT,6,2,XGA 60Hz ↵ @STT,6,2,XGA 60Hz ↵	
	Saving the current IN6 input timing in device table 2 with the name of "XGA 60Hz" Completed	
Remarks	These commands are only for analog input. These commands are valid only if the DVI input connector signal is set to analog and analog RGB/analog YPbPr signal is input. 【See: @GIN / @SIN DVI input connector signal】	

@GTK / @STK		Tracking
Getting	Command	@GTK ↵
	Response	@GTK, track_1, track_2 ↵
Setting	Command	@STK, input, track (, input, track) ↵
	Response	@STK, input, track (, input, track) ↵
Parameter		<p>input: Input channel MSD-S71/S72 : 0 = All analog inputs, 6 = IN6 (Analog), 7 = IN7 (Analog) MSD-S51/S52 : 0 = All analog inputs, 5 = IN5 (Analog)</p> <p>track_1 : Tracking IN6 (MSD-S71/S72) or IN5 (MSD-S51/S52)</p> <p>track_2 : Tracking IN7 (MSD-S71/S72)</p> <p>track : Tracking 0 to 63 [Default] 0 -1 = Not available, HDMI input connector is set to digital input (Only getting)</p>
Getting example		@GTK ↵ @GTK,4,5 ↵ Getting the tracking If no analog RGB/YPbPr signal is input, "0" is returned.
Setting example		@STK,6,4 ↵ @STK,6,4 ↵ Setting the IN6 tracking to "4" Completed
Remarks		These commands are only for analog input. These commands are valid only if the DVI input connector signal is set to analog and analog RGB/analog YPbPr signal is input. 【See: @GIN / @SIN DVI input connector signal】

3.3.9 Input channel automatic switching

@GAU / @SAU		Signal ON priority
Getting	Command	@GAU, window ↵
	Response	@GAU, window, priority_1, priority_2, priority_3, priority_4, priority_5, priority_6, priority_7 ↵
Setting	Command	@SAU, window, priority_1, priority_2, priority_3, priority_4, priority_5, priority_6, priority_7 (, window, priority_1···) ↵
	Response	@SAU, window, priority_1, priority_2, priority_3, priority_4, priority_5, priority_6, priority_7 (, window, priority_1···) ↵
Parameter		window: Window 0 = All windows (For setting only), 1 = OUT1 main window, 2 = OUT2 main window, 201 = OUT1 PinP window, 202 = OUT2 PinP window
		priority_1-7: IN1 to IN7 priority of input channel 0 = OFF [Default], 1 to 7 = Priority (Highest) to = Priority (Lowest)
Getting example		@GAU,1 ↵ @GAU,1,1,2,3,4,5,6,7 ↵
		Getting the priority of the OUT1 main window (When input signal is changed from "OFF" to "ON") IN1>IN2>···>IN7
Setting example		@SAU,1,7,6,5,4,3,2,1 ↵ @SAU,1,7,6,5,4,3,2,1 ↵
		Setting the priority of the OUT1 main window to IN7>IN6>···>IN1 (When input signal is changed from "OFF" to "ON") Completed
Remarks		—









@GOF / @SOF		Signal OFF priority
Getting	Command	@GOF, window
	Response	@GOF, window, priority_1, priority_2, priority_3, priority_4, priority_5, priority_6, priority_7
Setting	Command	@SOF, window, priority_1, priority_2, priority_3, priority_4, priority_5, priority_6, priority_7 (, window, priority_1···)
	Response	@SOF, window, priority_1, priority_2, priority_3, priority_4, priority_5, priority_6, priority_7 (, window, priority_1···)
Parameter		window: Window 0 = All windows (For setting only), 1 = OUT1 main window, 2 = OUT2 main window, 201 = OUT1 PinP window, 202 = OUT2 PinP window
		priority_1-7: IN1 to IN7 priority of input channel 0 = OFF [Default], 1 to 7 = Priority (Highest) to Priority (Lowest)
Getting example		@GOF,1 @GOF,1,1,2,3,4,5,6,7
		Getting the priority of the OUT1 main window (When input signal is changed from "ON" to "OFF") IN1>IN2>···>IN7
Setting example		@SOF,1,7,6,5,4,3,2,1 @SOF,1,7,6,5,4,3,2,1
		Setting the priority of the OUT1 main window to IN7>IN6>···>IN1 (When input signal is changed from "ON" to "OFF") Completed
Remarks		—









@GMT / @SMT		Ignoring duration after automatic switching
Getting	Command	@GMT ↵
	Response	@GMT, time_main_1, time_main_2, time_pinp_1, time_pinp_2 ↵
Setting	Command	@SMT, window, time (, window, time···) ↵
	Response	@SMT, window, time (, window, time···) ↵
Parameter		<p>window: Window</p> <p>0 = All windows, 1 = OUT1 main window, 2 = OUT2 main window, 201 = OUT1 PinP window, 202 = OUT2 PinP window</p> <p>time_main_1-2 : Ignoring duration of the OUT1/OUT2 main window time_pinp_1-2 : Ignoring duration of the OUT1/OUT2 PinP window time : Ignoring duration 0 to 999999 = 0 ms. to 999 s 999 ms. [Default] 0 s 000 ms.</p>
Getting example		<p>@GMT ↵</p> <p>@GMT,2000,300,1000,500 ↵</p> <p>Getting the ignoring duration after input channel automatic switching</p> <p>OUT1 main window: 2000 ms. (2 seconds) OUT2 main window: 300 ms. (0.3 seconds) OUT1 PinP window: 1000 ms. (1 seconds) OUT2 PinP window: 500 ms. (0.5 seconds)</p>
Setting example		<p>@SMT,1,10000 ↵</p> <p>@SMT,1,10000 ↵</p> <p>Setting the ignoring duration of the OUT1 main window after input channel automatic switching to 10000 ms. (10 seconds)</p> <p>Completed</p>
Remarks		—





@GAD / @SAD		Channel switching mode of automatic switching
Getting	Command	@GAD ↵
	Response	@GAD, switching_main_1, switching_main_2 ↵
Setting	Command	@SAD, output, switching (, output, switching) ↵
	Response	@SAD, output, switching (, output, switching) ↵
Parameter		output: Output channel 0 = All outputs, 1 = OUT1 main window, 2 = OUT2 main window switching_main_1-2: Switching mode of OUT1/OUT2 switching : Switching mode 0 = VIDEO, 1 = AUDIO, 2 = V&A [Default]
Getting example		@GAD ↵ @GAD,2,2 ↵ Getting the switching mode of the input channel automatic switching OUT1 and OUT2: V&A
Setting example		@SAD,1,0 ↵ @SAD,1,0 ↵ Setting the switching mode of the OUT1 input channel automatic switching to "0" (VIDEO) Completed
Remarks		—

3.3.10 Picture controls

@GOB / @SOB		Output brightness
Getting	Command	@GOB ↵
	Response	@GOB, bright_main_1, bright_main_2, bright_pinp_1, bright_pinp_2 ↵
Setting	Command	@SOB, window, bright (, window, bright···) ↵
	Response	@SOB, window, bright (, window, bright···) ↵
Parameter		window: Window 0 = All windows, 1 = OUT1 main window, 2 = OUT2 main window, 201 = OUT1 PinP window, 202 = OUT2 PinP window
		bright_main_1-2 : Output brightness of the OUT1/OUT2 main window [%] bright_pinp_1-2 : Output brightness of the OUT1/OUT2 PinP window [%] bright : Output brightness [%] 80 to 120 [Default] 100
Getting example		@GOB ↵
		@GOB,110,100,108,95 ↵
		Getting the output brightness OUT1 main window : 110% OUT2 main window : 100% OUT1 PinP window : 108% OUT2 PinP window : 95%
Setting example		@SOB,1,110 ↵
		@SOB,1,110 ↵
		Setting the output brightness of the OUT1 main window to 110% Completed
Remarks		—

@GOC / @SOC		Output contrast
Getting	Command	@GOC, window 
	Response	@GOC, window, red, green, blue 
Setting	Command	@SOC, window, red, green, blue (, window, red, green, blue···) 
	Response	@SOC, window, red, green, blue (, window, red, green, blue···) 
Parameter		window: Window 0 = All windows (For setting only), 1 = OUT1 main window, 2 = OUT2 main window, 201 = OUT1 PinP window, 202 = OUT2 PinP window
		red : Output contrast (Red) [%] green : Output contrast (Green) [%] blue : Output contrast (Blue) [%] 0 to 200 [Default] 100
Getting example		@GOC,1 
		@GOC,1,105,100,95  Getting the output contrast of the OUT1 main window Red: 105%, Green: 100%, Blue: 95%
Setting example		@SOC,1,105,100,95 
		@SOC,1,105,100,95  Setting the output contrast of the OUT1 main window to 105% for red, 100% for green, 95% for blue Completed
Remarks		—

@GGM / @SGM		Output gamma
Getting	Command	@GGM 
	Response	@GGM, gamma_main_1, gamma_main_2, gamma_pinp_1, gamma_pinp_2 
Setting	Command	@SGM, window, gamma (, window, gamma···) 
	Response	@SGM, window, gamma (, window, gamma···) 
Parameter		<p>window: Window</p> <p>0 = All windows, 1 = OUT1 main window, 2 = OUT2 main window, 201 = OUT1 PinP window, 202 = OUT2 PinP window</p> <p>gamma_main_1-2: Output gamma of the OUT1/OUT2 main window gamma_pinp_1-2 : Output gamma of the OUT1/OUT2 PinP window gamma : Output gamma 1 to 30 = 0.1 to 3.0 [Default] 10 = 1.0</p>
Getting example		<p>@GGM </p> <p>@GGM,22,25,20,30 </p> <p>Getting the output gamma</p> <p>OUT1 main window : 2.2 OUT2 main window : 2.5 OUT1 PinP window : 2.0 OUT2 PinP window : 3.0</p>
Setting example		<p>@SGM,1,22 </p> <p>@SGM,1,22 </p> <p>Setting the output gamma of the OUT1 main window to 2.2 Completed</p>
Remarks		—

@ODC		Output video correction initialization
Setting	Command	@ODC, window (, window···) 
	Response	@ODC, window (, window···) 
Parameter		<p>window: Window</p> <p>0 = All windows, 1 = OUT1 main window, 2 = OUT2 main window, 201 = OUT1 PinP window, 202 = OUT2 PinP window</p>
Setting example		<p>@ODC,1 </p> <p>@ODC,1 </p> <p>Initializing the following picture control settings:</p> <ul style="list-style-type: none"> - @GOB / @SOB Output brightness - @GOC / @SOC Output contrast - @GGM / @SGM Output gamma <p>Completed</p>
Remarks		—

@GFL / @SFL		Input sharpness
Getting	Command	@GFL ↵
	Response	@GFL, sharp_1, sharp_2, sharp_3, sharp_4, sharp_5, sharp_6, sharp_7 ↵
Setting	Command	@SFL, input, sharp (, input, sharp···) ↵
	Response	@SFL, input, sharp (, input, sharp···) ↵
Parameter		input: Input channel 0 = All inputs, 1 to 7 = IN1 to IN7 sharp_1-7 : IN1 to IN7 input sharpness sharp : Input sharpness -5 to +15 [Default] 0
Getting example		@GFL ↵ @GFL,5,0,0,0,0,0,0 ↵ Getting the input sharpness IN1 : +5 Other input channels : 0
Setting example		@SFL,1,5 ↵ @SFL,1,5 ↵ Getting the IN1 input sharpness to "+5" Completed
Remarks		—





@GIB / @SIB		Input brightness
Getting	Command	@GIB ↵
	Response	@GIB, bright_1, bright_2, bright_3, bright_4, bright_5, bright_6, bright_7 ↵
Setting	Command	@SIB, input, bright (, input, bright···) ↵
	Response	@SIB, input, bright (, input, bright···) ↵
Parameter		input: Input channel 0 = All inputs, 1 to 7 = IN1 to IN7 bright_1-7 : IN1 to IN7 input brightness [%] bright : Input brightness [%] 80 to 120 [Default] 100
Getting example		@GIB ↵ @GIB,110,100,100,100,100,100,100 ↵ Getting the input brightness IN1 : 110% Other input channels : 100%
Setting example		@SIB,3,110 ↵ @SIB,3,110 ↵ Setting the IN3 input brightness to 110% Completed
Remarks		—

@GIC / @SIC		Input contrast
Getting	Command	@GIC, input
	Response	@GIC, input, red, green, blue
Setting	Command	@SIC, input, red, green, blue (, input, red, green, blue···)
	Response	@SIC, input, red, green, blue (, input, red, green, blue···)
Parameter		input: Input channel 0 = All inputs (For setting only), 1 to 7 = IN1 to IN7 red : Input contrast (Red) [%] green : Input contrast (Green) [%] blue : Input contrast (Blue) [%] 0 to 200 [Default] 100
Getting example		@GIC,3 @GIC,3,105,100,95 Getting the IN3 input contrast Red: 105%, Green: 100%, Blue: 95%
Setting example		@SIC,3,105,100,95 @SIC,3,105,100,95 Setting the IN3 input contrast to 105% for red, 100% for green, 95% for blue Completed
Remarks		—









@GHU / @SHU		Input hue
Getting	Command	@GHU
	Response	@GHU, hue_1, hue_2, hue_3, hue_4, hue_5, hue_6, hue_7
Setting	Command	@SHU, input, hue (, input, hue···)
	Response	@SHU, input, hue (, input, hue···)
Parameter		input: Input channel 0 = All inputs, 1 to 7 = IN1 to IN7 hue_1-7 : IN1 to IN7 input hue [°] hue : Input hue [°] 0 to 359 [Default] 0
Getting example		@GHU @GHU,60,0,0,0,0,0,0 Getting the input hue IN1 : 60° Other inputs : 0°
Setting example		@SHU,1,60 @SHU,1,60 Setting the IN1 input hue to 60° Completed
Remarks		—

@GST / @SST		Input saturation
Getting	Command	@GST ↵
	Response	@GST, saturation_1, saturation_2, saturation_3, saturation_4, saturation_5, saturation_6, saturation_7 ↵
Setting	Command	@SST, input, saturation (, input, saturation···) ↵
	Response	@SST, input, saturation (, input, saturation···) ↵
Parameter		input: Input channel 0 = All inputs, 1 to 7 = IN1 to IN7 saturation_1-7 : IN1 to IN7 input saturation [%] saturation : Input saturation [%] 0 to 200 [Default] 100
Getting example		@GST ↵ @GST,100,100,100,100,105,100,100 ↵ Getting the input saturation IN5 : 105% Other inputs : 100%
Setting example		@SST,5,105 ↵ @SST,5,105 ↵ Setting the IN5 input saturation to 105% Completed
Remarks		—

@GSU / @SSU		Input black level
Getting	Command	@GSU ↵
	Response	@GSU, setup_1, setup_2, setup_3, setup_4, setup_5, setup_6, setup_7 ↵
Setting	Command	@SSU, input, setup (, input, setup···) ↵
	Response	@SSU, input, setup (, input, setup···) ↵
Parameter		input: Input channel 0 = All inputs, 1 to 7 = IN1 to IN7 setup_1-7 : IN1 to IN7 input black level [%] setup : Input black level [%] -20 to 20 = -20 × 0.5 (-10.0%) to +20 × 0.5 (+10.0%) [Default] 0 = ±0.0%
Getting example		@GSU ↵ @GSU,0,0,0,0,15,0,0 ↵ Getting the input black level IN5 : +7.5% Other inputs : 0%
Setting example		@SSU,5,15 ↵ @SSU,5,15 ↵ Setting the IN5 input black level to +7.5% Completed
Remarks		—

@IDC		Input video correction initialization
Setting	Command	@IDC, input (, input···) 
	Response	@IDC, input (, input···) 
Parameter		input: Input channel 0 = All inputs, 1 to 7 = IN1 to IN7
Setting example		@IDC,1 
		@IDC,1  Initializing the following picture control settings of IN1: - @GFL / @SFL Input sharpness - @GIB / @SIB Input brightness - @GIC / @SIC Input contrast - @GHU / @SHU Input hue - @GST / @SST Input saturation - @GSU / @SSU Input black level Completed
Remarks		—

3.3.11 Output audio

@GUC / @SUC		Output audio
Getting	Command	@GUC 
	Response	@GUC, audio_d1A, audio_d1B, audio_d2A, audio_d2B, audio_a1, audio_a2 
Setting	Command	@SUC, output, audio, (, output, audio···) 
	Response	@SUC, output, audio, (, output, audio···) 
Parameter		<p>output: Output audio connector</p> <p>0 = All outputs, 1 = HDMI OUT1A, 2 = HDBT OUT1B, 3 = HDMI OUT2A, 4 = HDBT OUT2B, 5 = Analog audio output 1, 6 = Analog audio output 2</p> <p>audio_d1A : Output audio of HDMI OUT1A audio_d1B : Output audio of HDBT OUT1B audio_d2A : Output audio of HDMI OUT2A audio_d2B : Output audio of HDBT OUT2B audio_a1 : Output audio of analog audio output 1 audio_a2 : Output audio of analog audio output 2 audio : Output audio</p> <p>0 = Not output, 1 = Output [Default]</p>
Getting example		<p>@GUC </p> <p>@GUC,1,0,0,0,0,0 </p> <p>Getting the output audio connectors Only HDMI OUT1A</p>
Setting example		<p>@SUC,1,1 </p> <p>@SUC,1,1 </p> <p>Setting HDMI OUT1A as an output audio connector Completed</p>
Remarks		—

@GAV / @SAV		Output audio level
Getting	Command	@GAV ↵
	Response	@GAV, level_d1, level_a1, level_d2, level_a2 ↵
Setting	Command	@SAV, output, connector, level ↵
	Response	@SAV, output, connector, level ↵
Parameter		<p>output: Output channel 1 = OUT1, 2 = OUT2</p> <p>connector: Output connector 1 = HDMI OUTA/HDBT OUTB, 2 = Analog audio output</p> <p>level_d1 : Output audio level of HDMI OUT1A/HDBT OUT1B [dB] level_a1 : Output audio level of Analog audio output 1 [dB] level_d2 : Output audio level of HDMI OUT2A/HDBT OUT2B [dB] level_a2 : Output audio level of Analog audio output 2 [dB] level : Output audio level [dB] -100 to 10 [Default] 0</p>
Getting example		<p>@GAV ↵ @GAV,1,-4,0,0 ↵</p> <p>Getting the output audio level HDMI OUT1A/HDBT OUT1B: +1 dB Analog audio output 1 : -4 dB All OUT2s : ±0 dB</p>
Setting example		<p>@SAV,1,1,-4 ↵ @SAV,1,1,-4 ↵</p> <p>Setting the HDMI OUT1A/HDBT OUT1B output audio level to -4 dB Completed</p>
Remarks		Unmuted if changing output audio level.

@SOL		Adjusting output audio level
Setting	Command	@SOL, output, connector, updown ↵
	Response	@SOL, output, connector, updown ↵
Parameter		<p>output: Output channel 1 = OUT1, 2 = OUT2</p> <p>connector: Output connector 1 = HDMI OUTA/HDBT OUTB, 2 = Analog audio output</p> <p>updown: Relative value [dB] -110 to 110 The specified value is added to the current output audio level. If the set output audio level exceeds the limit value (-100 dB to +10 dB), the limit value will be applied.</p>
Setting example		<p>@SOL,1,1,-1 ↵ @SOL,1,1,-1 ↵</p> <p>Decreasing the audio output level of the HDMI OUT1A/HDBT OUT1B connector by 1 dB Completed</p>
Remarks		Unmuted if changing output level.

@GOL		Output audio limit status
Getting	Command	@GOL, output ↵
	Response	@GOL, output, limit_d, limit_a ↵
Parameter		output: Output channel 1 = OUT1, 2 = OUT2
		limit_d: Limit status of HDMI OUTA/HDBT OUTB limit_a: Limit status of analog audio output -1 = Minimum value (-100 dB), 0 = Not reach limit value, 1 = Maximum value (+10 dB)
Getting example		@GOL,1 ↵ @GOL,1,1,-1 ↵
		Getting the limit status of the OUT1 output audio level HDMI OUTA/HDBT OUTB : Maximum value Analog audio output : Minimum value
Remarks		—

@GAM / @SAM		Audio mute
Getting	Command	@GAM ↵
	Response	@GAM, mute_1, mute_2 ↵
Setting	Command	@SAM, output, mute (, output, mute) ↵
	Response	@SAM, output, mute (, output, mute) ↵
Parameter		output: Output channel 0 = All outputs, 1 = OUT1, 2 = OUT2
		mute_1-2: OUT1/OUT2 audio mute mute : Audio mute 0 = OFF [Default], 1 = ON
Getting example		@GAM ↵ @GAM,1,0 ↵
		Getting the audio mute OUT1: ON (Mute) OUT2: OFF (Unmute)
Setting example		@SAM,1,1 ↵ @SAM,1,1 ↵
		Muting audio of OUT1 Completed
Remarks		—

@GSF / @SSF		Sampling frequency
Getting	Command	@GSF ↵
	Response	@GSF, frequency_1, frequency_2 ↵
Setting	Command	@SSF, output, frequency (output, frequency) ↵
	Response	@SSF, output, frequency (output, frequency) ↵
Parameter		output: Output channel 0 = All outputs, 1 = OUT1, 2 = OUT2
		frequency_1-2: OUT1/OUT2 sampling frequency frequency : Sampling frequency 0 = AUTO-A [Default], 1 = AUTO-B, 2 = 32 kHz, 3 = 44.1 kHz, 4 = 48 kHz, 5 = 88.2 kHz, 6 = 96 kHz, 7 = 192 kHz
Getting example		@GSF ↵
		@GSF,4,2 ↵
		Getting the output sampling frequency OUT1 : 48kHz OUT2 : 32 kHz
Setting example		@SSF,1,4 ↵
		@SSF,1,4 ↵
		Setting the OUT1 sampling frequency to 48 kHz Completed
Remarks	—	

@GFD		Actual sampling frequency
Getting	Command	@GFD ↵
	Response	@GFD, frequency_1, frequency_2 ↵
Parameter		frequency_1-2: OUT1/OUT2 sampling frequency 1 = 32 kHz, 2 = 44.1 kHz, 3 = 48 kHz [Default], 4 = 88.2 kHz, 5 = 96 kHz, 6 = 192 kHz
Getting example		@GFD ↵
		@GFD,5,3 ↵
		Getting the actual sampling frequency OUT1 : 96 kHz OUT2 : 48 kHz
Remarks	The sampling frequency that is output actually is returned. 【See: @GSF / @SSF Sampling frequency】	

@GMD / @SMD		Multi-channel audio output
Getting	Command	@GMD ↵
	Response	@GMD, multi_1, multi_2 ↵
Setting	Command	@SMD, output, multi (, output, multi) ↵
	Response	@SMD, output, multi (, output, multi) ↵
Parameter		<p>output: Output channel 0 = All outputs, 1 = OUT1, 2 = OUT2</p> <p>multi_1-2 : OUT1/OUT2 multi-channel audio output multi : Multi-channel audio output 0 = CH1/CH2 STEREO, 1 = CH3/CH4 STEREO, 2 = CH5/CH6 STEREO, 3 = CH7/CH8 STEREO, 4 = CH1/CH2 MONO, 5 = CH3/CH4 MONO, 6 = CH5/CH6 MONO, 7 = CH7/CH8 MONO, 8 = DOWN MIX [Default]</p>
Getting example		<p>@GMD ↵ @GMD,4,8 ↵</p> <p>Getting the multi-channel audio output OUT1 : Outputs monaural audio of CH1/CH2. OUT2 : Outputs downmixed audio.</p>
Setting example		<p>@SMD,1,8 ↵ @SMD,1,8 ↵</p> <p>Setting OUT1 to output downmixed audio Completed</p>
Remarks		—

@GCH / @SCH		Multi-channel audio output priority
Getting	Command	@GCH ↵
	Response	@GCH, priority_1, priority_2 ↵
Setting	Command	@SCH, output, priority (, output, priority) ↵
	Response	@SCH, output, priority (, output, priority) ↵
Parameter		<p>output: Output channel 0 = All outputs, 1 = OUT1, 2 = OUT2</p> <p>priority_1-2 : OUT1/OUT2 multi-channel audio output priority priority : Multi-channel audio output priority 0 = 2CH, 1 = MULTI [Default]</p>
Getting example		<p>@GCH ↵ @GCH,0,1 ↵</p> <p>Getting the multi-channel audio output priority OUT1 : 2CH audio has a priority. OUT2 : Multi-channel audio has a priority.</p>
Setting example		<p>@SCH,1,1 ↵ @SCH,1,1 ↵</p> <p>Setting the OUT1 multi-channel audio to have a priority Completed</p>
Remarks		—

@GAT / @SAT		Test tone
Getting	Command	@GAT [↵]
	Response	@GAT, tone_1, speaker_1, tone_2, speaker_2 [↵]
Setting	Command	@SAT, output, tone, speaker (, output, tone, speaker) [↵]
	Response	@SAT, output, tone, speaker (, output, tone, speaker) [↵]
Parameter		output: Output channel 0 = All outputs, 1 = OUT1, 2 = OUT2 tone_1-2 : OUT1/OUT2 test tone tone : Test tone 0 = OFF [Default], 1 = 1 kHz, 2 = 400 Hz speaker_1-2 : OUT1/OUT2 speaker speaker : Speaker 0 = ALL [Default], 1 = FRONT L/R, 2 = REAR L/R, 3 = REAR L/R CENTER, 4 = FRONT LEFT, 5 = FRONT RIGHT, 6 = LOW FREQUENCY EFFECT, 7 = FRONT CENTER, 8 = REAR LEFT, 9 = REAR RIGHT, 10 = REAR LEFT CENTER, 11 = REAR RIGHT CENTER
Getting example		@GAT [↵] @GAT,2,1,2,1 [↵]
		Getting the test tone output OUT1 and OUT2: Outputs test tone (400 Hz) to FRONT L/R.
Setting example		@SAT,1,1,0 [↵] @SAT,1,1,0 [↵]
		Setting all speakers to output 1kHz test tone (1kHz) Completed
Remarks		The test tone of LOW FREQUENCY EFFECT is 30Hz.

3.3.12 Input audio

@GAS / @SAS		Input audio
Getting	Command	@GAS ↵
	Response	@GAS, select_1, select_2, select_3, select_4, select_5, select_6, select_7 ↵
Setting	Command	@SAS, input, select (, input, select···) ↵
	Response	@SAS, input, select (, input, select···) ↵
Parameter		input: Input channel 0 = All input channels, 1 to 7 = IN1 to IN7
		select_1-7 : IN1 to IN7 input audio select : Input audio 0 = DIGITAL [Default], 1 = ANALOG1, 2 = ANALOG2, 3 = ANALOG3
Getting example		@GAS ↵ @GAS,1,0,0,0,0,0,0 ↵
		Getting the input audio IN1 : Analog audio 1 Other input channels: Digital audio
Setting example		@SAS,3,1 ↵ @SAS,3,1 ↵
		Setting the IN3 digital audio to Analog audio 1 Completed
Remarks		—

@GIO / @SIO		Input audio level offset (For each audio input connector)
Getting	Command	@GIO ↵
	Response	@GIO, level_d1, level_d2, level_d3, level_d4, level_d5, level_d6, level_d7, level_a1, level_a2, level_a3 ↵
Setting	Command	@SIO, input, level (, input, level···) ↵
	Response	@SIO, input, level (, input, level···) ↵
Parameter		input: Audio input connector 0 = All inputs, 1 to 7 = IN1 to IN7, 8 to 10 = ANALOG1 to ANALOG3 level_d1-d7 : IN1 to IN7 input audio level offset [dB] level_a1-a3 : ANALOG1 to ANALOG3 input audio level offset [dB] level : Input audio level offset [dB] -100 to 10 [Default] 0
Getting example		@GIO ↵ @GIO,0,0,0,0,-4,0,0,10,0,0 ↵ Getting the input audio level offset IN5 : -4 dB ANALOG1 : +10dB Other input channels : ±0 dB
Setting example		@SIO,5,-8 ↵ @SIO,5,-8 ↵ Setting the IN5 input audio level offset to -8 dB Completed
Remarks		—

@GSO / @SSO		Input audio level offset (For each audio input channel)
Getting	Command	@GSO ↵
	Response	@GSO, level_1, level_2, level_3, level_4, level_5, level_6, level_7 ↵
Setting	Command	@SSO, input, level (, input, level···) ↵
	Response	@SSO, input, level (, input, level···) ↵
Parameter		input: Audio input channel 0 = All inputs, 1 to 7 = IN1 to IN7 level_1-7 : IN1 to IN7 input audio level offset [dB] level : Input audio level offset [dB] -100 to 10 [Default] 0
Getting example		@GSO ↵ @GSO,0,0,0,0,-4,0,0 ↵ Getting the input audio level offset IN5 : -4 dB Other inputs : ±0 dB
Setting example		@SSO,5,-8 ↵ @SSO,5,-8 ↵ Setting the IN5 digital input audio level offset to -8 dB Completed
Remarks		—

@SDZ		Adjusting input audio level
Setting	Command	@SDZ, input, updown (, input, updown···) ↵
	Response	@SDZ, input, updown (, input, updown···) ↵
Parameter		input: Audio input connector 0 = All inputs, 1 to 7 = IN1 to IN7, 8 to 10 = ANALOG1 to ANALOG3
		updown: Relative value [dB] -110 to 110 The specified value is added/subtracted to/from the current input audio level offset. If the total value exceeds the limit value (-100 dB to +10 dB), the limit value will be applied.
Setting example		@SDZ,1,-1 ↵ @SDZ,1,-1 ↵ Decreasing the IN1 input audio level by 1 dB Completed
Remarks		—

@GDZ		Input audio limit status
Getting	Command	@GDZ ↵
	Response	@GDZ, level_d1, level_d2, level_d3, level_d4, level_d5, level_d6, level_d7, level_a1, level_a2, level_a3 ↵
Parameter		level_d1-d7: IN1 to IN7 limit status of input audio level level_a1-a3: ANALOG1 to ANALOG3 limit status of input audio level -1 = Minimum value (-100 dB), 0 = Not reach limit value, 1 = Maximum value (+10 dB)
Getting example		@GDZ ↵ @GDZ,1,0,0,0,0,0,0,0,0,0 ↵ Getting the limit status of input audio level IN1 : Maximum value Other inputs : Not reach limit value
Remarks		—

@GLY / @SLY		Input Lip Sync
Getting	Command	@GLY [↵]
	Response	@GLY, time_1, time_2, time_3, time_4, time_5, time_6, time_7 [↵]
Setting	Command	@SLY, input, time (, input, time···) [↵]
	Response	@SLY, input, time (, input, time···) [↵]
Parameter		input: Input channel 0 = All inputs, 1 to 7 = IN1 to IN7 time_1-7 : IN1 to IN7 input Lip Sync [ms.] time : Input Lip Sync [ms.] 0 to 70 [Default] 0
Getting example		@GLY [↵] @GLY,0,0,0,2,0,0,0 [↵] Getting the input Lip Sync IN4 : 2 ms. Other inputs : 0 ms.
Setting example		@SLY,4,20 [↵] @SLY,4,20 [↵] Setting the IN4 Lip Sync to 20 ms. Completed
Remarks		The total delay of input and output Lip Sync is up to 70 ms. 【See: @GLO / @SLO Output Lip Sync】

@GAW / @SAW		Stable input audio wait
Getting	Command	@GAW [↵]
	Response	@GAW, wait_1, wait_2, wait_3, wait_4, wait_5, wait_6, wait_7 [↵]
Setting	Command	@SAW, input, wait (, input, wait···) [↵]
	Response	@SAW, input, wait (, input, wait···) [↵]
Parameter		input: Digital input channel 0 = All digital inputs, 1 to 7 = IN1 to IN7 wait_1-7 : IN1 to IN7 wait until input audio becomes stable wait : Wait until input audio becomes stable 0 = OFF, 1 = ON [Default]
Getting example		@GAW [↵] @GAW,1,1,0,1,1,1,1 [↵] Getting the mode of stable input audio wait Only IN3: Disabled
Setting example		@SAW,1,0 [↵] @SAW,1,0 [↵] Disabling stable input audio wait of IN1 Completed
Remarks		These commands are only for digital input. With DVI input connector signals, these commands are valid only if the connector is set to digital. 【See: @GIN / @SIN DVI input connector signal】 These commands are valid only if input audio is set to digital. 【See: @GAS / @SAS Input audio】

3.3.13 EDID

@GED / @SED		EDID selection
Getting	Command	@GED ↵
	Response	@GED, edid_1, edid_2, edid_3, edid_4, edid_5, edid_6, edid_7 ↵
Setting	Command	@SED, input, edid (, input, edid···) ↵
	Response	@SED, input, edid (, input, edid···) ↵
Parameter		input: Input channel 0 = All digital inputs, 1 to 7 = IN1 to IN7
		edid_1-7 : IN1 to IN7 EDID edid : EDID 0 = Built-in EDID [Default], 1 = HDMI OUT1A MONITOR, 2 = HDBT OUT1B MONITOR, 3 = HDMI OUT2A MONITOR, 4 = HDBT OUT2B MONITOR, 101 to 108 = COPY DATA 1 to 8, -1 = Not available, DVI input connector is set to analog input (Only getting)
Getting example		@GED ↵ @GED,0,0,0,3,0,0,0 ↵
		Getting the EDID selection IN4 : EDID of the sink device that is connected to HDMI OUT2A Other inputs : Built-in EDID
Setting example		@SED,2,3 ↵ @SED,2,3 ↵
		Setting the IN2 EDID to the EDID that is read from the connected sink device of HDMI OUT2A Completed
Remarks		These commands are only for digital input. With DVI input connector signals, these commands are valid only if the connector is set to digital. 【See: @GIN / @SIN DVI input connector signal】 In order to use a copied data, copy the EDID data from the sink device in “@RME Copying EDID” in advance.

@GVF / @SVF		Resolution																				
Getting	Command	@GVF ↵																				
	Response	@GVF, resolution_1, resolution_2, resolution_3, resolution_4, resolution_5, resolution_6, resolution_7 ↵																				
Setting	Command	@SVF, input, resolution (, input, resolution···) ↵																				
	Response	@SVF, input, resolution (, input, resolution···) ↵																				
Parameter		<p>input: Input channel 0 = All inputs, 1 to 7 = IN1 to IN7</p> <p>resolution_1-7 : IN1 to IN7 resolution resolution : Resolution</p> <table border="0"> <tr> <td>0 = SVGA(800x600),</td> <td>1 = XGA(1024x768),</td> </tr> <tr> <td>2 = VESA720p(1280x720),</td> <td>3 = 720p(1280x720),</td> </tr> <tr> <td>4 = WXGA(1280x768),</td> <td>5 = WXGA(1280x800),</td> </tr> <tr> <td>6 = QuadVGA(1280x960),</td> <td>7 = SXGA(1280x1024),</td> </tr> <tr> <td>8 = WXGA(1360x768),</td> <td>9 = WXGA(1366x768),</td> </tr> <tr> <td>10 = SXGA+(1400x1050),</td> <td>11 = WXGA+(1440x900),</td> </tr> <tr> <td>12 = WXGA++(1600x900),</td> <td>13 = UXGA(1600x1200),</td> </tr> <tr> <td>14 = WSXGA+(1680x1050),</td> <td>15 = 1080i(1920x1080),</td> </tr> <tr> <td>16 = VESA1080p(1920x1080),</td> <td>17 = 1080p(1920x1080),</td> </tr> <tr> <td>18 = WUXGA(1920x1200),</td> <td>19 = QWXGA(2048x1152)</td> </tr> </table> <p>[Default] 1080p(1920x1080)</p>	0 = SVGA(800x600),	1 = XGA(1024x768),	2 = VESA720p(1280x720),	3 = 720p(1280x720),	4 = WXGA(1280x768),	5 = WXGA(1280x800),	6 = QuadVGA(1280x960),	7 = SXGA(1280x1024),	8 = WXGA(1360x768),	9 = WXGA(1366x768),	10 = SXGA+(1400x1050),	11 = WXGA+(1440x900),	12 = WXGA++(1600x900),	13 = UXGA(1600x1200),	14 = WSXGA+(1680x1050),	15 = 1080i(1920x1080),	16 = VESA1080p(1920x1080),	17 = 1080p(1920x1080),	18 = WUXGA(1920x1200),	19 = QWXGA(2048x1152)
0 = SVGA(800x600),	1 = XGA(1024x768),																					
2 = VESA720p(1280x720),	3 = 720p(1280x720),																					
4 = WXGA(1280x768),	5 = WXGA(1280x800),																					
6 = QuadVGA(1280x960),	7 = SXGA(1280x1024),																					
8 = WXGA(1360x768),	9 = WXGA(1366x768),																					
10 = SXGA+(1400x1050),	11 = WXGA+(1440x900),																					
12 = WXGA++(1600x900),	13 = UXGA(1600x1200),																					
14 = WSXGA+(1680x1050),	15 = 1080i(1920x1080),																					
16 = VESA1080p(1920x1080),	17 = 1080p(1920x1080),																					
18 = WUXGA(1920x1200),	19 = QWXGA(2048x1152)																					
Getting example		@GVF ↵ @GVF,6,6,9,6,6,6,6 ↵																				
		Getting the resolution IN3 : WXGA Other inputs : QuadVGA																				
Setting example		@SVF,0,12 ↵ @SVF,0,12 ↵																				
		Setting EDID of all input channels to WXGA++ Completed																				
Remarks		—																				

@RME		Copying EDID
Setting	Command	@RME, output, number (, name) ↵
	Response	@RME, output, number (, name) ↵
Parameter		output: Connector to be read 1 = HDMI OUT1A, 2 = HDBT OUT1B, 3 = HDMI OUT2A, 4 = HDBT OUT2B number: Destination COPY DATA number 1 to 8 name: COPY DATA name Up to 10 characters from 20 to 7D of ASCII code If you skip this parameter ("name"), only EDID settings are saved without changing its name.
Setting example		@RME,1,1 ↵ @RME,1,1 ↵ Copying the EDID data of the sink device connected to HDMI OUT1A and saving it in COPY DATA 1 Completed
Setting example		@RME,1,4,800x600 ↵ @RME,1,4,800x600 ↵ Copying the EDID data of the sink device connected to HDMI OUT1A, naming it "800x600" and saving it in COPY DATA 4 Completed
Remarks		Copied EDID is used for each input connector. <div style="text-align: right;">【See: @GED / @SED EDID selection】</div>







@GHL / @SHL		HDMI/DVI
Getting	Command	@GHL ↵
	Response	@GHL, mode_1, mode_2, mode_3, mode_4, mode_5, mode_6, mode_7 ↵
Setting	Command	@SHL, input, mode (, input, mode···) ↵
	Response	@SHL, input, mode (, input, mode···) ↵
Parameter		input: Input channel 0 = All digital inputs, 1 to 7 = IN1 to IN7 mode_1-7 : IN1 to IN7 input signal mode mod : Input signal mode 0 = DVI, 1 = HDMI [Default], -1 = Not available, universal input connector is set to analog input (Only getting)
Getting example		@GHL ↵ @GHL,1,1,1,0,1,1,1 ↵ Getting the input signal mode IN4 : DVI Other inputs : HDMI
Setting example		@SHL,4,0 ↵ @SHL,4,0 ↵ Setting the IN4 input signal mode to DVI Completed
Remarks		These commands are only for digital input. With DVI input connector signals, these commands are valid only if the connector is set to digital. <div style="text-align: right;">【See: @GIN / @SIN DVI input connector signal】</div>

@GHZ / @SHZ		Frame rate
Getting	Command	@GHZ ↵
	Response	@GHZ, frame_1, frame_2, frame_3, frame_4, frame_5, frame_6, frame_7 ↵
Setting	Command	@SHZ, input, frame (, input, frame···) ↵
	Response	@SHZ, input, frame (, input, frame···) ↵
Parameter		input: Input channel 0 = All inputs, 1 to 7 = IN1 to IN7 frame_1-7 : IN1 to IN7 frame rate frame : Frame rate 0 = 60 Hz [Default], 1 = 50 Hz
Getting example		@GHZ ↵ @GHZ,1,1,1,0,1,1,1 ↵
		Getting the frame rate of the input video IN4 : 60 Hz Other inputs : 50 Hz
Setting example		@SHZ,4,0 ↵ @SHZ,4,0 ↵
		Setting the IN4 frame rate of the input video to 60 Hz Completed
Remarks		—

@GAF / @SAF		Audio format																
Getting	Command	@GAF, input																
	Response	@GAF, input, format, frequency (, format, frequency···)																
Setting	Command	@SAF, input, format, frequency (, format, frequency···)																
	Response	@SAF, input, format, frequency (, format, frequency···)																
Parameter		<p>input: Input channel 0 = All digital inputs (For setting only), 1 to 7 = IN1 to IN7</p> <p>format: Audio format 0 = LPCM, 1 = Dolby Digital, 2 = AAC, 3 = Dolby Digital Plus, 4 = DTS, 5 = DTS-HD, 6 = Dolby TrueHD, -1 = Not available, DVI input connector is set to analog input (Only getting) [Default] only PCM can be output</p> <p>frequency: Maximum sampling frequency 0 = Not output (For setting only), 1 = 32 kHz, 2 = 44.1 kHz, 3 = 48 kHz, 4 = 88.2 kHz, 5 = 96 kHz, 6 = 176.4 kHz, 7 = 192 kHz [Default] DTS-HD: 192 kHz, Dolby TrueHD: 96 kHz, other formats:48 kHz</p> <p>Maximum settable sampling frequency depends on the audio format.</p> <table border="1"> <thead> <tr> <th>Audio format</th> <th>Maximum sampling frequency (kHz)</th> </tr> </thead> <tbody> <tr> <td>LPCM</td> <td>32/44.1/48/88.2/96/176.4/192</td> </tr> <tr> <td>Dolby Digital</td> <td>Not output/32/44.1/48</td> </tr> <tr> <td>AAC</td> <td>Not output/32/44.1/48/88.2/96</td> </tr> <tr> <td>Dolby Digital Plus</td> <td>Not output/32/44.1/48</td> </tr> <tr> <td>DTS</td> <td>Not output/32/44.1/48/96</td> </tr> <tr> <td>DTS-HD</td> <td>Not output/44.1/48/88.2/96/176.4/192</td> </tr> <tr> <td>Dolby TrueHD</td> <td>Not output/44.1/48/88.2/96/176.4/192</td> </tr> </tbody> </table> <p>For getting : The set audio formats and maximum sampling frequency is returned. For setting : Set the desired audio formats and the maximum sampling frequencies, the other audio formats is set to 0 (Not output) automatically. PCM is always enabled, you can skip this menu unless you need to change the sampling frequency.</p>	Audio format	Maximum sampling frequency (kHz)	LPCM	32/44.1/48/88.2/96/176.4/192	Dolby Digital	Not output/32/44.1/48	AAC	Not output/32/44.1/48/88.2/96	Dolby Digital Plus	Not output/32/44.1/48	DTS	Not output/32/44.1/48/96	DTS-HD	Not output/44.1/48/88.2/96/176.4/192	Dolby TrueHD	Not output/44.1/48/88.2/96/176.4/192
Audio format	Maximum sampling frequency (kHz)																	
LPCM	32/44.1/48/88.2/96/176.4/192																	
Dolby Digital	Not output/32/44.1/48																	
AAC	Not output/32/44.1/48/88.2/96																	
Dolby Digital Plus	Not output/32/44.1/48																	
DTS	Not output/32/44.1/48/96																	
DTS-HD	Not output/44.1/48/88.2/96/176.4/192																	
Dolby TrueHD	Not output/44.1/48/88.2/96/176.4/192																	

@GAF / @SAF		Audio format (Cont'd)
Getting example	Command	@GAF,1 ↵
	Response	@GAF,1,0,7 ↵
		Getting the IN1 audio format Up to LPCM 192 kHz
Setting example	Command	@SAF,2,4,3 ↵
	Response	@SAF,2,4,3 ↵
		Enabling IN2 to output LPCM and DTS up to 48 kHz (The maximum LPCM sampling frequency is not changed.) Completed
Remarks	<p>These commands are only for digital input. With DVI input connector signals, these commands are valid only if the connector is set to digital.</p> <p style="text-align: right;">【See: @GIN / @SIN DVI input connector signal】</p>	

@GSP / @SSP		Speaker configuration
Getting	Command	@GSP, input ↵
	Response	@GSP, input, number, speaker_1 (, speaker_2···) ↵
Setting	Command	@SSP, input, number (, speaker_1, speaker_2···) ↵
	Response	@SSP, input, number (, speaker_1, speaker_2···) ↵
Parameter	input: Input channel 0 = All digital inputs (For setting only), 1 to 7 = IN1 to IN7	
	number: The number of speakers 1 to 8 [Default] 2, -1 = Not available, DVI input connector is set to analog input (Only getting)	
	speaker_1-8: Speakers to be used 0 = Front Left/Right [Default], 1 = Low Frequency Effect, 2 = Front Center, 3 = Rear Left/Right, 4 = Rear Center, 5 = Front Left/Right Center, 6 = Rear Left/Right Center, 7 = Front Left/Right Wide, 8 = Front Left/Right High, 9 = Top Center, 10 = Front Center High	

@GSP / @SSP	Speaker configuration (Cont'd)																																																																																																																							
Parameter	<p>For getting : The number of speakers and which speakers will be used is returned. For setting : If you do not specify the speaker configuration, the following configuration will be applied depending on the set number of speakers.</p> <table border="1" data-bbox="454 387 1426 790"> <thead> <tr> <th rowspan="2">number</th> <th colspan="11">speaker</th> </tr> <tr> <th>0</th> <th>1</th> <th>2</th> <th>3</th> <th>4</th> <th>5</th> <th>6</th> <th>7</th> <th>8</th> <th>9</th> <th>10</th> </tr> </thead> <tbody> <tr> <td>1</td> <td>OFF</td> <td>OFF</td> <td>ON</td> <td>OFF</td> <td>OFF</td> <td>OFF</td> <td>OFF</td> <td>OFF</td> <td>OFF</td> <td>OFF</td> <td>OFF</td> </tr> <tr> <td>2</td> <td>ON</td> <td>OFF</td> <td>OFF</td> <td>OFF</td> <td>OFF</td> <td>OFF</td> <td>OFF</td> <td>OFF</td> <td>OFF</td> <td>OFF</td> <td>OFF</td> </tr> <tr> <td>3</td> <td>ON</td> <td>ON</td> <td>OFF</td> <td>OFF</td> <td>OFF</td> <td>OFF</td> <td>OFF</td> <td>OFF</td> <td>OFF</td> <td>OFF</td> <td>OFF</td> </tr> <tr> <td>4</td> <td>ON</td> <td>ON</td> <td>ON</td> <td>OFF</td> <td>OFF</td> <td>OFF</td> <td>OFF</td> <td>OFF</td> <td>OFF</td> <td>OFF</td> <td>OFF</td> </tr> <tr> <td>5</td> <td>ON</td> <td>ON</td> <td>OFF</td> <td>ON</td> <td>OFF</td> <td>OFF</td> <td>OFF</td> <td>OFF</td> <td>OFF</td> <td>OFF</td> <td>OFF</td> </tr> <tr> <td>6</td> <td>ON</td> <td>ON</td> <td>ON</td> <td>ON</td> <td>OFF</td> <td>OFF</td> <td>OFF</td> <td>OFF</td> <td>OFF</td> <td>OFF</td> <td>OFF</td> </tr> <tr> <td>7</td> <td>ON</td> <td>ON</td> <td>ON</td> <td>ON</td> <td>ON</td> <td>OFF</td> <td>OFF</td> <td>OFF</td> <td>OFF</td> <td>OFF</td> <td>OFF</td> </tr> <tr> <td>8</td> <td>ON</td> <td>ON</td> <td>ON</td> <td>ON</td> <td>OFF</td> <td>OFF</td> <td>ON</td> <td>OFF</td> <td>OFF</td> <td>OFF</td> <td>OFF</td> </tr> </tbody> </table> <p>The specified number and the total number of speakers do not match, the number is set automatically based on the setting of speakers to be used. In case the number exceeds the settable range, an error is returned.</p>	number	speaker											0	1	2	3	4	5	6	7	8	9	10	1	OFF	OFF	ON	OFF	OFF	OFF	OFF	OFF	OFF	OFF	OFF	2	ON	OFF	OFF	OFF	OFF	OFF	OFF	OFF	OFF	OFF	OFF	3	ON	ON	OFF	OFF	OFF	OFF	OFF	OFF	OFF	OFF	OFF	4	ON	ON	ON	OFF	OFF	OFF	OFF	OFF	OFF	OFF	OFF	5	ON	ON	OFF	ON	OFF	OFF	OFF	OFF	OFF	OFF	OFF	6	ON	ON	ON	ON	OFF	OFF	OFF	OFF	OFF	OFF	OFF	7	ON	ON	ON	ON	ON	OFF	OFF	OFF	OFF	OFF	OFF	8	ON	ON	ON	ON	OFF	OFF	ON	OFF	OFF	OFF	OFF
number	speaker																																																																																																																							
	0	1	2	3	4	5	6	7	8	9	10																																																																																																													
1	OFF	OFF	ON	OFF	OFF	OFF	OFF	OFF	OFF	OFF	OFF																																																																																																													
2	ON	OFF	OFF	OFF	OFF	OFF	OFF	OFF	OFF	OFF	OFF																																																																																																													
3	ON	ON	OFF	OFF	OFF	OFF	OFF	OFF	OFF	OFF	OFF																																																																																																													
4	ON	ON	ON	OFF	OFF	OFF	OFF	OFF	OFF	OFF	OFF																																																																																																													
5	ON	ON	OFF	ON	OFF	OFF	OFF	OFF	OFF	OFF	OFF																																																																																																													
6	ON	ON	ON	ON	OFF	OFF	OFF	OFF	OFF	OFF	OFF																																																																																																													
7	ON	ON	ON	ON	ON	OFF	OFF	OFF	OFF	OFF	OFF																																																																																																													
8	ON	ON	ON	ON	OFF	OFF	ON	OFF	OFF	OFF	OFF																																																																																																													
Getting example	<p>@GSP,1 </p> <p>@GSP,1,6,0,1,2,3 </p> <p>Getting the IN1 speaker configuration Six speakers are used - Front Left/Right - Low Frequency Effect - Front Center - Rear Left/Right</p>																																																																																																																							
Setting example	<p>@SSP,2,8 </p> <p>@SSP,2,8 </p> <p>Assigning the following eight speakers to IN2: - Front Left/Right - Low Frequency Effect - Front Center - Rear Left/Right - Rear Left/Right Center Completed</p>																																																																																																																							
Setting example	<p>@SSP,3,8,0,3,5,6,7 </p> <p>@ERR,1 </p> <p>Assigning the following ten speakers to IN3: - Front Left/Right - Rear Left/Right - Front Left/Right Center - Rear Left/Right Center - Front Left/Right Wide The number of speakers exceeds the settable value.</p>																																																																																																																							
Remarks	<p>These commands are only for digital input. With DVI input connector signals, these commands are valid only if the connector is set to digital.</p> <p style="text-align: right;">【See: @GIN / @SIN DVI input connector signal】</p>																																																																																																																							

3.3.14 RS-232C









@GCT / @SCT		RS-232C communication
Getting	Command	@GCT, port ↵
	Response	@GCT, port, baudrate, length, parity, stop ↵
Setting	Command	@SCT, port, baudrate, length, parity, stop ↵
	Response	@SCT, port, baudrate, length, parity, stop ↵
Parameter		port: Connector 1 = RS (RS-232C), 2 = HDBT OUT1B, 3 = HDBT OUT2B
		baudrate: Baud rate 0 = 4800 bps, 1 = 9600 bps [Default], 2 = 14400 bps, 3 = 19200 bps, 4 = 38400 bps, 5 = 57600 bps, 6 = 115200 bps
		length: Data bit length 0 = 7 bit, 1 = 8 bit [Default]
		parity: Parity check 0 = NONE [Default], 1 = ODD, 2 = EVEN
		stop: Stop bit 0 = 1 bit [Default], 1 = 2 bit
Getting example		@GCT,1 ↵ @GCT,1,3,1,0,0 ↵
		Getting the RS-232C connector communication settings - Baud rate : 19200 bps - Data bit length: 8 bit - Parity check : NONE - Stop bit : 1 bit
Setting example		@SCT,1,3,1,0,0 ↵ @SCT,1,3,1,0,0 ↵
		Setting the RS-232C connector communication as follows: - Baud rate : 19200 bps - Data bit length: 8 bit - Parity check : NONE - Stop bit : 1 bit Completed
Remarks		Set the RS-232C communication based on RS-232C specification of the control devices.





@GCF / @SCF		RS-232C operation mode
Getting	Command	@GCF ↵
	Response	@GCF, mode_1, mode_2, mode_3 ↵
Setting	Command	@SCF, port, mode ↵
	Response	@SCF, port, mode ↵
Parameter		port: Connector 0 = All connectors, 1 = RS (RS-232C), 2 = HDBT OUT1B, 3 = HDBT OUT2B mode_1: Operation mode of RS (RS-232C) mode_2: Operation mode of HDBT OUT1B mode_3: Operation mode of HDBT OUT2B mode : Operation mode 0 = RECEIVER mode, 1 = TRANSMITTER mode [Default] RS (RS-232C) = 0, HDBT OUT1B = 1, HDBT OUT2B = 1
Getting example		@GCF ↵
		@GCF,1,1,1 ↵
		Getting the RS-232C operation mode All connectors: TRANSMITTER mode
Setting example		@SCF,1,1 ↵
		@SCF,1,1 ↵
		Setting the RS-232C connector to TRANSMITTER mode Completed
Remarks		To control the MSD-S from control devices, set this menu to "RECEIVER" mode. To control external devices from the MSD-S, set this menu to "TRANSMITTER" mode.

3.3.15 LAN









@GIP / @SIP		IP address
Getting	Command	@GIP ↵
	Response	@GIP, unit_1, unit_2, unit_3, unit_4 ↵
Setting	Command	@SIP, unit_1, unit_2, unit_3, unit_4 ↵
	Response	@SIP, unit_1, unit_2, unit_3, unit_4 ↵
Parameter		unit_1 to unit_4: Upper bit of the IP address to Lower bit of the IP address 0 to 255 = 8 bit (Decimal notation) [Default] 192.168.1.199
Getting example		@GIP ↵ @GIP,192,168,3,2 ↵ Getting the IP address of the MSD-S 192.168.3.2
Setting example		@SIP,192,168,3,2 ↵ @SIP,192,168,3,2 ↵ Setting the IP address to 192.168.3.2 Completed
Remarks		—

@GSB / @SSB		Subnet mask
Getting	Command	@GSB ↵
	Response	@GSB, unit_1, unit_2, unit_3, unit_4 ↵
Setting	Command	@SSB, unit_1, unit_2, unit_3, unit_4 ↵
	Response	@SSB, unit_1, unit_2, unit_3, unit_4 ↵
Parameter		unit_1 to unit_4: Upper bit of the subnet mask to Lower bit of the subnet mask 0 to 255 = 8 bit (Decimal notation) [Default] 255.255.255.0
Getting example		@GSB ↵ @GSB,255,255,192,0 ↵ Getting the subnet mask of the MSD-S 255.255.192.0 (= 18 bit)
Setting example		@SSB,255,255,192,0 ↵ @SSB,255,255,192,0 ↵ Setting the subnet mask of the MSD-S to 255.255.192.0 (= 18 bit) Completed
Remarks		—

@GGW / @SGW		Gateway address
Getting	Command	@GGW 
	Response	@GGW, unit_1, unit_2, unit_3, unit_4 
Setting	Command	@SGW, unit_1, unit_2, unit_3, unit_4 
	Response	@SGW, unit_1, unit_2, unit_3, unit_4 
Parameter		unit_1 to unit_4: Upper bit of the gateway address to Lower bit of the gateway address 0 to 255 = 8 bit (Decimal notation) [Default] 192.168.1.200
Getting example	@GGW 	
	@GGW,192,168,1,254 	
		Getting the gateway address 192.168.1.254
Setting example	@SGW,192,168,1,254 	
	@SGW,192,168,1,254 	
		Setting the gateway address to 192.168.1.254 Completed
Remarks		—

@GMC		MAC address
Getting	Command	@GMC 
	Response	@GMC, unit_1, unit_2, unit_3, unit_4, unit_5, unit_6 
Parameter		unit_1 to unit_6: Upper bit of the MAC address to Lower bit of the MAC address 00 to FF = 8 bit (in hexadecimal)
Getting example	@GMC 	
	@GMC,00,08,E5,5F,00,00 	
		Getting the MAC address 00-08-E5-5F-00-00
Remarks		—

@GLP / @SLP		TCP port number
Getting	Command	@GLP ↵
	Response	@GLP, port_1, port_2, port_3, port_4, port_5, port_6, port_7, port_8 ↵
Setting	Command	@SLP, connection, port (, connection, port···) ↵
	Response	@SLP, connection, port (, connection, port···) ↵
Parameter		connection: Connection number 0 = All connections, 1 to 8 = Connection 1 to 8 port_1-8 : Connection 1 to 8 TCP port number port : TCP port number 23, 80, 1100, 5000 to 5999, 6000 to 6999 [Default] Connection 1 to 3 = 1100, Connection 4 to 6 = 23, Connection 7 to 8 = 80
Getting example		@GLP ↵ @GLP,1100,1100,1100,23,23,23,80,80 ↵ Getting the TCP port number - Connection 1 to 3 : 1100 - Connection 4 to 6 : 23 - Connection 7 and 8 : 80
Setting example		@SLP,8,6000 ↵ @SLP,8,6000 ↵ Setting the port number of Connection 8 to "6000" Completed
Remarks		—

@GLF / @SLF		LAN operation mode
Getting	Command	@GLF, connection 
	Response	@GLF, connection, mode (, ip_1, ip_2, ip_3, ip_4, pjlink, tcp, password) 
Setting	Command	@SLF, connection, mode (, ip_1, ip_2, ip_3, ip_4, pjlink, tcp, password) 
	Response	@SLF, connection, mode (, ip_1, ip_2, ip_3, ip_4, pjlink, tcp, password) 
Parameter		<p>connection: Connection number 1 to 8 = Connection 1 to 8</p> <p>mode: Operation mode 0 = RECEIVER mode [Default], 1 = TRANSMITTER mode</p> <p>ip_1 to ip_4: Upper bit of the destination IP address to Lower bit of the destination IP address 0 to 255 = 8 bit (Decimal notation) [Default] 192.168.1.198 Available only in TRANSMITTER mode.</p> <p>pjlink: PJLink protocol connection 0 = PJLink not used [Default], 1 = PJLink used Available only in TRANSMITTER mode.</p> <p>tcp: Destination port number 1 to 65535 [Default] 1100 Available only in TRANSMITTER mode and "pjlink" is set to "0" (PJLink not used). If "pjlink" is set to "1" (PJLink used), "tcp" is "4352" fixed.</p> <p>password: Password of PJLink protocol Up to 32 characters of the following ASCII codes: 20, 30 to 39, 41 to 5A, 61 to 7A (alphanumeric characters). [Default] All: 20 (space) Available only in TRANSMITTER mode and "pjlink" is set to "1" (PJLink used). For getting : Returned only if the password is set. For setting : You can skip this password setting if you do not use password authentication for PJLink protocol connection.</p>
Getting example		<p>@GLF,3 </p> <p>@GLF,3,1,192,168,1,2,1,PROJECTOR1 </p> <p>Getting the operation mode of Connection 3</p> <ul style="list-style-type: none"> - Operation mode : TRANSMITTER mode - The destination IP address : 192.168.1.2 - PJLink : To be used - Password : PROJECTOR1
Setting example		<p>@SLF,3,1,192,168,1,2,1 </p> <p>@SLF,3,1,192,168,1,2,1 </p> <p>Setting Connection 3 as follows:</p> <ul style="list-style-type: none"> - Operation mode : TRANSMITTER mode - The destination IP address : 192.168.1.2 - PJLink : To be used - Password : Disabling password authentication <p>Completed</p>
Remarks		To control the MSD-S from control devices, set this menu to "RECEIVER" mode. To control external devices from the MSD-S, set this menu to "TRANSMITTER" mode.

3.3.16 Control commands

@GEC / @SEC		Registering/Editing control command (Communication command)																		
Getting	Command	@GEC, cmd ↵																		
	Response	@GEC, cmd, delay, port, memo, length, command, timeout, retry, interval, retryover, display (, rcv_1, rcv_2···) ↵																		
Setting	Command	@SEC, cmd, delay, port, memo, length, command, timeout, retry, interval, retryover, display (, rcv_1, rcv_2···) ↵																		
	Response	@SEC, cmd, delay, port, memo, length, command, timeout, retry, interval, retryover, display (, rcv_1, rcv_2···) ↵																		
Parameter		cmd: Control command number 1 to 32																		
		delay: Delay time 0 to 999999 = 0 ms. to 999 s 999 ms. [Default] 0 s 000 ms.																		
		port: Output port 1 to 4095																		
		<table border="1"> <thead> <tr> <th>bit</th> <th>7</th> <th>6</th> <th>5</th> <th>4</th> <th>3</th> <th>2</th> <th>1</th> <th>0</th> </tr> </thead> <tbody> <tr> <td>port</td> <td>LAN 5</td> <td>LAN 4</td> <td>LAN 3</td> <td>LAN 2</td> <td>LAN 1</td> <td>HDBT OUT2B RS-232C</td> <td>HDBT OUT1B RS-232C</td> <td>RS-232C</td> </tr> </tbody> </table>	bit	7	6	5	4	3	2	1	0	port	LAN 5	LAN 4	LAN 3	LAN 2	LAN 1	HDBT OUT2B RS-232C	HDBT OUT1B RS-232C	RS-232C
		bit	7	6	5	4	3	2	1	0										
		port	LAN 5	LAN 4	LAN 3	LAN 2	LAN 1	HDBT OUT2B RS-232C	HDBT OUT1B RS-232C	RS-232C										
		<table border="1"> <thead> <tr> <th>bit</th> <th>15</th> <th>14</th> <th>13</th> <th>12</th> <th>11</th> <th>10</th> <th>9</th> <th>8</th> </tr> </thead> <tbody> <tr> <td>port</td> <td>—</td> <td>—</td> <td>—</td> <td>—</td> <td>LOOP BACK</td> <td>LAN 8</td> <td>LAN 7</td> <td>LAN 6</td> </tr> </tbody> </table>	bit	15	14	13	12	11	10	9	8	port	—	—	—	—	LOOP BACK	LAN 8	LAN 7	LAN 6
		bit	15	14	13	12	11	10	9	8										
		port	—	—	—	—	LOOP BACK	LAN 8	LAN 7	LAN 6										
		“1” is for the bit of the output port to send a command. The setting value is converted from binary to decimal. (Since 12 bit to 15 bit are not used, they are always “0”). For example, if you want to send a command from RS-232C, specify “1”. If sending a command from LAN1, specify “8”.																		
		memo: Memo Up to 14 characters from 20 to 7D of ASCII code except for 2C (,)																		
		length: Data size of send command (The number of bytes) 0 to 30																		
		command: Send command data (ASCII code) Specify “length” ×2 digits with 0 to 9, A to F, a to f: (4 bit per digit in hexadecimal)																		
		timeout: Time-out duration 0 to 99999 = 0 ms. to 99 s 999 ms.																		
retry: The number of retries 0 to 99																				
interval : Retry interval 0 to 99999 = 0 ms. to 99 s 999 ms.																				
retryover: Processing at retry over 0 = Stop processing, 1 = Continue processing																				
display: Displaying received data 0 = Communication command control																				

@GEC / @SEC	Registering/Editing control command (Communication command) (Cont'd)
Parameter	recv_1-32: Presence or absence of reply command check 1 to 32 For getting : Reply command numbers are separated from each other by a comma. For setting : The reply command number to be checked can be specified. Up to 32 commands can be specified by separating them by a comma. If you send only parameters of reply command number you want to check, the reply commands without sent parameter are automatically set to "not check". Register reply commands in " @GRC / @SRC Registering/Editing reply command ".
Getting example	<pre>@GEC,1 ↵</pre> <pre>@GEC,1,10,1,POWER,7,5057204F4E0D0A,1000,2,500,0,0,1,2 ↵</pre> Getting the settings registered in Control command number 1 <ul style="list-style-type: none"> - Delay time : 10 ms. - Output port : RS-232C - Memo : POWER - Data size : 7 bytes - Command data : PW ON CR LF (ASCII codes) - Time-out : 1000 ms. - The number of retries : 2 times - Retry interval : 500 ms. - Retry over : Stop - Received data : Not displayed - Reply command : Check 1 and 2
Setting example	<pre>@SEC,2,0,2048,IN1 SELECT,10,405353572C312C310D0A,0,0,0,1,0 ↵</pre> <pre>@SEC,2,0,2048,IN1 SELECT,10,405353572C312C310D0A,0,0,0,1,0 ↵</pre> Setting Control command 2 as follows: <ul style="list-style-type: none"> - Delay time : 0 ms. - Output port : LOOP BACK - Memo : IN1 SELECT - Data size : 10 bytes - Command data : @SSW,1,1 CR LF (ASCII codes) - Time-out : 0 ms. - The number of retries : 0 time - Retry interval : 0 ms. - Retry over : Execute - Received data : Not displayed - Reply command : Not check Completed
Remarks	—









@GEC / @SEC		Registering/Editing control command (Displaying received data)																																				
Getting	Command	@GEC, cmd ↵																																				
	Response	@GEC, cmd, delay, port, memo, length, command, timeout, retry, interval, retryover, display, delimiter ↵																																				
Setting	Command	@SEC, cmd, delay, port, memo, length, command, timeout, retry, interval, retryover, display, delimiter ↵																																				
	Response	@SEC, cmd, delay, port, memo, length, command, timeout, retry, interval, retryover, display, delimiter ↵																																				
Parameter		<p>cmd: Control command number 1 to 32</p> <p>delay: Delay time 0 to 999999 = 0 ms. to 999 s 999 ms.</p> <p>port: Output port 1 to 4095</p> <table border="1"> <thead> <tr> <th>bit</th> <th>7</th> <th>6</th> <th>5</th> <th>4</th> <th>3</th> <th>2</th> <th>1</th> <th>0</th> </tr> </thead> <tbody> <tr> <td>port</td> <td>LAN 5</td> <td>LAN 4</td> <td>LAN 3</td> <td>LAN 2</td> <td>LAN 1</td> <td>HDBT OUT2B RS-232C</td> <td>HDBT OUT1B RS-232C</td> <td>RS-232C</td> </tr> </tbody> </table> <table border="1"> <thead> <tr> <th>bit</th> <th>15</th> <th>14</th> <th>13</th> <th>12</th> <th>11</th> <th>10</th> <th>9</th> <th>8</th> </tr> </thead> <tbody> <tr> <td>port</td> <td>—</td> <td>—</td> <td>—</td> <td>—</td> <td>LOOP BACK</td> <td>LAN 8</td> <td>LAN 7</td> <td>LAN 6</td> </tr> </tbody> </table> <p>“1” is for the bit of the output port to send a command. The setting value is converted from binary to decimal. (Since 12 bit to 15 bit are not used, they are always “0”). For example, if you want to send a command from RS-232C, specify “1”. If sending a command from LAN1, specify “8”.</p> <p>memo: Memo Up to 14 characters from 20 to 7D of ASCII code except for 2C (,)</p> <p>length: Data size of send command (The number of bytes) 0 to 30</p> <p>command: Send command data Specify “length” ×2 digits with 0 to 9, A to F, a to f: (4 bit per digit in hexadecimal)</p> <p>timeout: Time-out duration 0 to 99999 = 0 ms. to 99 s 999 ms.</p> <p>retry: The number of retries 0 to 99</p> <p>interval: Retry interval 0 to 99999 = 0 ms. to 99 s 999 ms.</p> <p>retryover: Processing at retry over 0 = Stop processing, 1 = Continue processing</p> <p>display: Displaying received data 1 = In ASCII codes, 2 = In hexadecimals</p> <p>delimiter: Delimiter 2 digits of 0 to 9, A to F, a to f = 4 bit per digit (in hexadecimal) for monitoring delimiter 100 = Not monitor</p>	bit	7	6	5	4	3	2	1	0	port	LAN 5	LAN 4	LAN 3	LAN 2	LAN 1	HDBT OUT2B RS-232C	HDBT OUT1B RS-232C	RS-232C	bit	15	14	13	12	11	10	9	8	port	—	—	—	—	LOOP BACK	LAN 8	LAN 7	LAN 6
bit	7	6	5	4	3	2	1	0																														
port	LAN 5	LAN 4	LAN 3	LAN 2	LAN 1	HDBT OUT2B RS-232C	HDBT OUT1B RS-232C	RS-232C																														
bit	15	14	13	12	11	10	9	8																														
port	—	—	—	—	LOOP BACK	LAN 8	LAN 7	LAN 6																														

@GEC / @SEC	Registering/Editing control command (Displaying received data) (Cont'd)
Getting example	<pre>@GEC,3 ↵ @GEC,3,0,8,POWER STATUS,9,47455420504F570D0A,2000,2,200,0,1,0D ↵</pre> <p>Getting the settings registered in Control command number 3</p> <ul style="list-style-type: none"> - Delay time : 0 ms. - Output port : LAN1 - Memo : POWER STATUS - Data size : 9 bytes - Command data : GET POW <i>CR LF</i> (ASCII codes) - Time-out : 2000 ms. - The number of retries : 2 times - Retry interval : 200 ms. - Retry over : Stop - Received data : In ASCII codes - Delimiter : 0D in hex (CR =ASCII codes)
Setting example	<pre>@SEC,3,0,8,POWER STATUS,9,47455420504F570D0A,2000,2,200,0,1,0D ↵ @SEC,3,0,8,POWER STATUS,9,47455420504F570D0A,2000,2,200,0,1,0D ↵</pre> <p>Setting Control command 3 as follows:</p> <ul style="list-style-type: none"> - Delay time : 0 ms. - Output port : LAN1 - Memo : POWER STATUS - Data size : 9 bytes - Command data : GET POW <i>CR LF</i> (ASCII codes) - Time-out : 2000 ms. - The number of retries : 2 times - Retry interval : 200 ms. - Retry over : Stop - Received data : In ASCII codes - Delimiter : 0D in hex (CR =ASCII codes) <p>Completed</p>
Remarks	—

@GEC / @SEC		Registering/Editing control command (Contact closure)
Getting	Command	@GEC, cmd <input type="checkbox"/>
	Response	@GEC, cmd, delay, port, memo, ccno, cc, pulse (, ccno, cc, pulse···) <input type="checkbox"/>
Setting	Command	@SEC, cmd, delay, port, memo, ccno, cc, pulse (, ccno, cc, pulse···) <input type="checkbox"/>
	Response	@SEC, cmd, delay, port, memo, ccno, cc, pulse (, ccno, cc, pulse···) <input type="checkbox"/>
Parameter		cmd: Control command number 1 to 32
		delay: Delay time 0 to 999999 = 0 ms. to 999 s 999 ms.
		port: Output port Contact closure control: 4096, fixed
		memo: Memo Up to 14 characters from 20 to 7D of ASCII code except for 2C (,)
		ccno: Contact closure number 1 = CH1, 2 = CH2, 3 = CH3 For getting : Only contact closure numbers to be used for controlling. For setting : Specify only contact closure numbers that are used for controlling. For contact closure numbers that do not specify parameter, "Not control" is set.
		cc: Contact closure control 0 = OFF, 1 = ON, 2 = Toggle, 3 = Not control
		pulse: Pulse width 0 = Hold, 100 to 9990 = 100 ms. to 9990 ms. (by 10 ms.) Pulse width after the completion of contact closure.
Getting example		@GEC,7 <input type="checkbox"/> @GEC,7,20,4096,SCREEN UP,1,1,100 <input type="checkbox"/>
		Getting the settings registered in Control command number 7 - Delay time : 20 ms. - Memo : SCREEN UP - CH1 Contact closure : ON for 100 ms. - Other contact closures: Not control
Setting example		@SEC,6,50,4096,PROJECTOR ON,1,0,200,2,1,0 <input type="checkbox"/> @SEC,6,50,4096,PROJECTOR ON,1,0,200,2,1,0 <input type="checkbox"/>
		Setting Control command number 6 as follows: - Delay time : 50 ms. - Memo : PROJECTOR ON - CH1 Contact closure: OFF for 200 ms. - CH2 Contact closure: ON - CH3 Contact closure: Not control Completed
Remarks		—

@GEC / @SEC		Registering/Editing control command (CEC)
Getting	Command	@GEC, cmd
	Response	@GEC, cmd, delay, port, memo, error, output, cec (, output, cec···)
Setting	Command	@SEC, cmd, delay, port, memo, error, output, cec (, output, cec···)
	Response	@SEC, cmd, delay, port, memo, error, output, cec (, output, cec···)
Parameter		<p>cmd: Control command number 1 to 32</p> <p>delay: Delay time 0 to 999999 = 0 ms. to 999 s 999 ms.</p> <p>port: Output port CEC control: 8192, fixed.</p> <p>memo: Memo Up to 14 characters from 20 to 7D of ASCII code except for 2C (,)</p> <p>error: Processing if no response from sink device. 0 = Stop processing, 1 = Continue processing</p> <p>output: Output connector 1 = HDMI OUT1A, 2 = HDBT OUT1B, 3 = HDMI OUT2A, 4 = HDBT OUT2B For getting : Only output connectors to be used for controlling. For setting : Specify only output connectors that are used for controlling. For output connectors that do not specify parameter, "Not control" is set.</p> <p>cec: Control command 0 = Not control, 1 = POWER OFF, 2 = POWER ON</p>
Getting example		<p>@GEC,7 </p> <p>@GEC,7,0,8192,DISPLAY1 ON,0,1,2 </p> <p>Getting the settings registered in Control command number 7</p> <ul style="list-style-type: none"> - Delay time : 0 ms. - Memo : DISPLAY1 ON - Error : Stop - HDMI OUT1A sink device: Turning ON - Other output connectors : Not control
Setting example		<p>@SEC,7,0,8192,DISPLAY1 ON,0,1,2 </p> <p>@SEC,7,0,8192,DISPLAY1 ON,0,1,2 </p> <p>Setting Control command number 7 as follows:</p> <ul style="list-style-type: none"> - Delay time : 0 ms. - Memo : DISPLAY1 ON - Error : Stop - HDMI OUT1A sink device: Turning ON - Other output connectors : Not control <p>Completed</p>
Remarks		—

@GRC / @SRC		Registering/Editing reply command
Getting	Command	@GRC, reply
	Response	@GRC, reply, process, length, command, mask, memo
Setting	Command	@SRC, reply, process, length, command, mask, memo
	Response	@SRC, reply, process, length, command, mask, memo
Parameter		reply: Reply command number 1 to 32
		process: Process 0 = Stop processing, 1 = Continue processing, 2 = Resending commands
		length: Reply command data size (bytes) 0 to 30
		command: Reply command data Specify "length" ×2 digits with 0 to 9, A to F, a to f: (4 bit per digit in hexadecimal)
		mask: Mask data Specify "length" ×2 digits with 0 to 9, A to F, a to f: (4 bit per digit in hexadecimal)
		memo: Memo Up to 14 characters from 20 to 7D of ASCII code except for 2C (,)
Getting example		@GRC,2
		@GRC,2,0,1,40,40,NG
		Getting the settings registered in Reply command number 2 - Processing : Stop - Data size : 1 byte - Command data: 40 (In hex) - Mask data : 40 (Checking the second bit from the top) - Memo : NG
Setting example		@SRC,1,1,9,52454356204F4B0D0A,FFFFFFFFFFFFFFFF,OK
		@SRC,1,1,9,52454356204F4B0D0A,FFFFFFFFFFFFFFFF,OK
		Setting Reply command number 1 as follows - Processing : Continue - Data size : 9 bytes - Command data: RECV OK CR LF (ASCII codes) - Mask data : ALL: FF (Checking all bits) - Memo : OK Completed
Remarks		—

@GCC / @SCC		Command link
Getting	Command	@GCC, event 
	Response	@GCC, event, c_1 (, c_2, c_3····) 
Setting	Command	@SCC, event, c_1 (, c_2, c_3····) 
	Response	@SCC, event, c_1 (, c_2, c_3····) 
Parameter		<p>event: Control command execution condition For settable values, see the “[Table 3.4]”</p> <p>c_1-10: Send command 0 = Not link, 1 to 32 = Control command 1 to 32</p> <p>Control commands that are registered in one of the following commands can be linked.</p> <ul style="list-style-type: none"> - @GEC / @SEC Registering/Editing control command (Communication command) - @GEC / @SEC Registering/Editing control command (Displaying received data) - @GEC / @SEC Registering/Editing control command (Contact closure) - @GEC / @SEC Registering/Editing control command (CEC)
Getting example		@GCC,23 
		@GCC,23,5,2,1 
		Getting control commands that will be executed when the MSD-S is powered on Executing in order of Control command 5, 2, and 1
Setting example		@SCC,23,5,2,1 
		@SCC,23,5,2,1 
		Executing in order of Control command 5, 2, and 1 when the MSD-S is powered on Completed
Remarks		—

[Table 3.4] Control command execution condition

event	Execution condition	event	Execution condition
1	COMMAND F1-PLANE A	25	VIDEO: MAIN1-IN1
2	COMMAND F1-PLANE B	26	VIDEO: MAIN1-IN2
3	COMMAND F2-PLANE A	27	VIDEO: MAIN1-IN3
4	COMMAND F2-PLANE B	28	VIDEO: MAIN1-IN4
5	COMMAND F3-PLANE A	29	VIDEO: MAIN1-IN5
6	COMMAND F3-PLANE B	30	VIDEO: MAIN1-IN6
7	COMMAND F4-PLANE A	31	VIDEO: MAIN1-IN7
8	COMMAND F4-PLANE B	32	VIDEO: MAIN1-OFF
9	COMMAND F5-PLANE A	33	AUDIO: MAIN1-IN1
10	COMMAND F5-PLANE B	34	AUDIO: MAIN1-IN2
11	COMMAND F6-PLANE A	35	AUDIO: MAIN1-IN3
12	COMMAND F6-PLANE B	36	AUDIO: MAIN1-IN4
13	COMMAND F7-PLANE A	37	AUDIO: MAIN1-IN5
14	COMMAND F7-PLANE B	38	AUDIO: MAIN1-IN6
15	COMMAND F8-PLANE A	39	AUDIO: MAIN1-IN7
16	COMMAND F8-PLANE B	40	AUDIO: MAIN1-OFF
17	COMMAND F9-PLANE A	41	VIDEO: MAIN2-IN1
18	COMMAND F9-PLANE B	42	VIDEO: MAIN2-IN2
19	COMMAND FN1-PLANE A	43	VIDEO: MAIN2-IN3
20	COMMAND FN1-PLANE B	44	VIDEO: MAIN2-IN4
21	COMMAND FN2-PLANE A	45	VIDEO: MAIN2-IN5
22	COMMAND FN2-PLANE B	46	VIDEO: MAIN2-IN6
23	POWER ON	47	VIDEO: MAIN2-IN7
24	STANDBY	48	VIDEO: MAIN2-OFF
		49	AUDIO: MAIN2-IN1
		50	AUDIO: MAIN2-IN2
		51	AUDIO: MAIN2-IN3
		52	AUDIO: MAIN2-IN4
		53	AUDIO: MAIN2-IN5
		54	AUDIO: MAIN2-IN6
		55	AUDIO: MAIN2-IN7
		56	AUDIO: MAIN2-OFF

@GTG / @STG		Toggle operation
Getting	Command	@GTG, event (, event···)
	Response	@GTG, event, toggle (, event, toggle···)
Setting	Command	@STG, event, toggle (, event, toggle···)
	Response	@STG, event, toggle (, event, toggle···)
Parameter		event: Command execution condition 0 = All control commands, 1 to 9 = F1 button to F9 button, 10 = FN1 button, 11 = FN2 button toggle: Toggle operation 0 = Disabled [Default], 1 = Enabled
Getting example		@GTG,1 @GTG,1,1 Getting the toggle operation of the F1 button Enabled
Setting example		@STG,1,1 @STG,1,1 Setting the F1 button to "1" (Enabled) Completed
Remarks		—

@GUP / @SUP		Plane to be executed when powered ON
Getting	Command	@GUP, event (, event···)
	Response	@GUP, event, plane (, event, plane···)
Setting	Command	@SUP, event, plane (, event, plane···)
	Response	@SUP, event, plane (, event, plane···)
Parameter		event: Command execution condition 0 = All control commands, 1 to 9 = F1 button to F9 button, 10 = FN1 button, 11 = FN2 button plane: Plane to be executed when powered ON 0 = AUTO [Default], 1 = PLANE A, 2 = PLANE B
Getting example		@GUP,1 @GUP,1,1 Getting the plane to be executed for the F1 button F1 button executes PLANE A
Setting example		@SUP,1,1 @SUP,1,1 Setting the F1 button to execute PLANE A Completed
Remarks		—

@EXC		Command execution
Setting	Command	@EXC, command_1 (, command_2···) ↵
	Response	@EXC, command_1 (, command_2···) ↵
Parameter		command_1-5: Control command 1 to 32 = CMD 1 to CMD 32, A/a to I/i = F1 button to F9 button, J/j = FN1 button, K/k = FN2 button
Setting example		@EXC,1,2,3 ↵ @EXC,1,2,3 ↵
		Executing COMMAND in order of 1→2→3 Completed
Setting example		@EXC,6 ↵ @EXC,6,RECV:POWER OFF ↵
		Executing CMD 6 Completed If a command for displaying received data is executed, the received result will be displayed.
Remarks		It may take some time to return a reply command.

@GSK / @SSK		FN button status
Getting	Command	@GSK ↵
	Response	@GSK, onoff_1, onoff_2 ↵
Setting	Command	@SSK, button, onoff (, button, onoff) ↵
	Response	@SSK, button, onoff (, button, onoff) ↵
Parameter		button_1-2: FN button 0 = All FN buttons, 1 = FN1 button, 2 = FN2 button onoff_1-2: FN1 and FN2 button status onoff : FN button status 0 = OFF, 1 = ON, -1 = Not available, the button is not assigned to "COMMAND" (Only getting) OFF to ON: PLANE-A command is executed. ON to OFF: PLANE-B command is executed.
Getting example		@GSK ↵ @GSK,1,0 ↵
		Getting the FN button status FN1 button : ON FN2 button : OFF
Setting example		@SSK,1,1 ↵ @SSK,1,1 ↵
		Setting the FN1 button to ON Completed
Remarks		It may take some time to return a reply command. These commands are valid only if FN button functions are assigned to "COMMAND". 【See: @GFA / @SFA Assigning function】

@DEC		Initializing registered command and link
Setting	Command	@DEC, no_1 (, no_2, no_3···)
	Response	@DEC, no_1 (, no_2, no_3···)
Parameter		no_1-32: Commands or links you want to initialize 1 to 32 : Control command 1 to 32, 101 to 132: Reply command 1 to 32, ("1xx": xx is the reply command number) 201 to 256: Control command association 1 to 56 ("2xx": xx is the control command execution condition number) 【See: [Table 3.4] Control command execution condition】
Setting example		@DEC,221
		@DEC,221 Deleting the COMMAND FN2-PLANE A link Completed
Remarks		—





@GIT / @SIT		Invalid duration at control command execution
Getting	Command	@GIT
	Response	@GIT, time
Setting	Command	@SIT, time
	Response	@SIT, time
Parameter		time: Invalid duration 0 to 999999 = 0 ms. to 999 s 999 ms. [Default] 0 s 000 ms.
Getting example		@GIT
		@GIT,2000 Getting the invalid duration at control command execution Disabling the operation during control command execution or 2000 ms. (2 seconds) after control command starts
Setting example		@SIT,2000
		@SIT,2000 Setting the invalid duration at control command execution to 2000 ms. (2 seconds) Completed
Remarks		These commands are valid only if FN button functions are assigned to "COMMAND". 【See: @GCC / @SCC Command link】





@GTL / @STL		Illuminating function buttons
Getting	Command	@GTL, button (, button···)
	Response	@GTL, button, led (, button, led···)
Setting	Command	@STL, button, led (, button, led···)
	Response	@STL, button, led (, button, led···)
Parameter		<p>button: Function button 0 = All function buttons, 1 to 9 = F1 button to F9 button, 10 = FN1 button, 11 = FN2 button</p> <p>If "0 = All function buttons" is selected, illuminating conditions of all buttons will be returned in order.</p> <p>led: Illuminating condition</p> <p>If a command only for one plane (PLANE A) is registered: 0 = Illuminates if a control command is registered 1 = Illuminates while a control command is being executed</p> <p>If commands for both two planes (PLANE A and PLANE B) are registered: 0 = A control command(s) that is linked to a button is executed by pressing the desired button when the control command execution button illuminates/blinks.</p> <p style="padding-left: 40px;">Illuminates : Control command registered to PLANE A. Blinks : Control command registered to PLANE B.</p> <p>1 = The control command that is linked to a button is executed by pressing a desired button when the control command execution button illuminates/ does not illuminate.</p> <p style="padding-left: 40px;">Illuminates : Control command registered to PLANE A Does not illuminate : Control command registered to PLANE B</p> <p>[Default] F1 to F9 button : 0 FN1 button, FN2 button : 1</p>
Getting example		@GTL,3 @GTL,3,0 Getting the illuminating condition of the F3 button Illuminates if F3 button is registered. (If a command only for one plane is registered.)
Setting example		@STL,3,1 @STL,3,1 Setting the F3 button to illuminate while a control command is being executed (If a command only for one plane is registered.) Completed
Remarks		—





@GTF / @STF		Function button blinking duration
Getting	Command	@GTF, button (, button···) ↵
	Response	@GTF, button, blink (, button, blink···) ↵
Setting	Command	@STF, button, blink (, button, blink···) ↵
	Response	@STF, button, blink (, button, blink···) ↵
Parameter		<p>button: Function buttons 0 = All function buttons, 1 to 4 = F1 button to F4 button, 10 = FN1 button, 11 = FN2 button</p> <p>If "0 = All function buttons" is selected, illuminating conditions of all buttons will be returned in order.</p> <p>blink: Blinking duration -1 = Blinks while a control command is being executed, 0 = Not blink, 1 to 1000 = Blinks for the specified time (1 sec. to 1000 sec.)</p> <p>[Default] F1 button to F4 button : 0 FN1 button, FN2 button : -1</p>
Getting example		@GTF,1 ↵ @GTF,1,-1 ↵ Getting the blinking duration of the F1 button Blinks while a control command is being executed
Setting example		@STF,1,5 ↵ @STF,1,5 ↵ Setting the F1 blinking duration to 5 seconds after control command execution starts Completed
Remarks		Buttons on WEB browser do not blink.

@GFA / @SFA		Assigning function
Getting	Command	@GFA ↵
	Response	@GFA, function_1, function_2, function_3, function_4, function_5, function_6 ↵
Setting	Command	@SFA, button, function ↵
	Response	@SFA, button, function ↵
Parameter		<p>button: Function buttons 0 = All function buttons, 1 to 4 = F1 to F4 button, 10 = FN1 button, 11 = FN2 button</p> <p>function_1-6 : Assigning function to F1 button to F4 button, FN1 button, and FN2 button</p> <p>function : Assigning function 0 = COMMAND [Default], 1 = OUT1 PinP PATTERN, 2 = OUT2 PinP PATTERN, 21 = PinP WINDOW, 41 to 49 = CROSSPOINT No.1 to No.9, 61 to 68 = PRESET MEMORY No.1 to No.8</p>
Getting example		@GFA ↵
		@GFA,1,0,0,0,0,0 ↵
		Getting the function that is assigned to each button F1 : OUT1 PinP PATTERN Other buttons : COMMAND
Setting example		@SFA,1,21 ↵
		@SFA,1,21 ↵
		Assigning "PinP WINDOW" to F1 button Completed
Remarks	—	

3.3.17 Preset memory

@RCM		Recalling crosspoint memory
Setting	Command	@RCM, xpoint 
	Response	@RCM, xpoint 
Parameter		xpoint: Crosspoint memory 1 to 9
Setting example		@RCM,1 
		@RCM,1 
		Recalling the video/audio input channel assignment and layout pattern of Crosspoint memory 1 Completed
Remarks		—

@RCV		Recalling crosspoint memory (Setting video input channel)
Setting	Command	@RCV, xpoint 
	Response	@RCV, xpoint 
Parameter		xpoint: Crosspoint memory 1 to 9
Setting example		@RCV,1 
		@RCV,1 
		Recalling the MAIN and PinP video input channel assignment and layout pattern of Crosspoint memory 1 Completed
Remarks		—

@RCA		Recalling crosspoint memory (Setting audio input channel)
Setting	Command	@RCA, xpoint 
	Response	@RCA, xpoint 
Parameter		xpoint: Crosspoint memory 1 to 9
Setting example		@RCA,1 
		@RCA,1 
		Recalling the MAIN audio input channel of Crosspoint memory 1 Completed
Remarks		—

@SCM / @SEM		Saving crosspoint memory
Setting	Description	Overwriting all
	Command	@SCM, xpoint (, name) ↵
	Response	@SCM, xpoint (, name) ↵
Setting	Description	Overwriting partly*
	Command	@SEM, xpoint (, name) ↵
	Response	@SEM, xpoint (, name) ↵
Parameter		<p>xpoint: Crosspoint memory 1 to 9</p> <p>name: Crosspoint memory name Up to 10 characters from 20 to 7D from ASCII code If you skip this parameter ("name"), crosspoint and layout pattern settings are saved without changing its name.</p>
Setting example		<p>@SCM,2 ↵ @SCM,2 ↵</p> <p>Saving the current video/audio input channels and layout pattern in Crosspoint memory 2 without changing memory name Completed</p>
Setting example		<p>@SEM,2,XPS2 ↵ @SEM,2,XPS2 ↵</p> <p>Saving the current video/audio input channels and layout pattern in Crosspoint memory 2 with the name of "XPS2" Information that is set to "Not control" will be kept. Completed</p>
Remarks		<p>*Overwriting partly: Items with "Not control" setting in crosspoint memory editing are saved with the "Not control" setting.</p> <p style="text-align: right;">【See: @GCM / @ECM Editing crosspoint memory】</p>

@SCV / @SEV		Saving crosspoint memory (Setting video input channel)
Setting	Description	Overwriting all
	Command	@SCV, xpoint (, name) ↵
	Response	@SCV, xpoint (, name) ↵
Setting	Description	Overwriting partly
	Command	@SEV, xpoint (, name) ↵
	Response	@SEV, xpoint (, name) ↵
Parameter		<p>xpoint: Crosspoint memory 1 to 9</p> <p>name: Crosspoint memory name Up to 10 characters from 20 to 7D from ASCII code If you skip this parameter ("name"), crosspoint and layout pattern settings are saved without changing its name.</p>
Setting example		<p>@SCV,2 ↵ @SCV,2 ↵</p> <p>Saving the current MAIN and PinP video channels and PinP pattern in Crosspoint memory 2 without changing memory name Completed</p>
Setting example		<p>@SEV,2,XPS2 ↵ @SEV,2,XPS2 ↵</p> <p>Saving the current MAIN and PinP video input channels and layout pattern in Crosspoint memory 2 with the name of "XPS2" Information that is set to "Not control" will be kept. Completed</p>
Remarks		<p>*Overwriting partly: Items with "Not control" setting in crosspoint memory editing are saved with the "Not control" setting. 【See: @GCM / @ECM Editing crosspoint memory】</p>

@SCA / @SEA		Saving crosspoint memory (Setting audio input channel)
Setting	Description	Overwriting all
	Command	@SCA, xpoint (, name) ↵
	Response	@SCA, xpoint (, name) ↵
Setting	Description	Overwriting partly
	Command	@SEA, xpoint (, name) ↵
	Response	@SEA, xpoint (, name) ↵
Parameter		<p>xpoint: Crosspoint memory 1 to 9</p> <p>name: Crosspoint name Up to 10 characters from 20 to 7D from ASCII code If you skip this parameter ("name"), only crosspoint settings are saved without changing its name.</p>
Setting example		<p>@SCA,2 ↵ @SCA,2 ↵</p> <p>Saving the current MAIN audio input channel in Crosspoint memory 2 without changing memory name Completed</p>
Setting example		<p>@SEA,2,XPS2 ↵ @SEA,2,XPS2 ↵</p> <p>Saving the current MAIN audio input channel in Crosspoint memory 2 with the name of "XPS2" Information that is set to "Not control" will be kept. Completed</p>
Remarks		<p>*Overwriting partly: Items with "Not control" setting in crosspoint memory editing are saved with the "Not control" setting. 【See: @GCM / @ECM Editing crosspoint memory】</p>

@GCM / @ECM		Editing crosspoint memory
Getting	Command	@GCM, xpoint [↵]
	Response	@GCM, xpoint, main_v_1, main_a_1, main_v_2, main_a_2, pinp_v_1, pinp_a_1, pinp_v_2, pinp_a_2, pinp_on_1, pinp_on_2, name [↵]
Setting	Command	@ECM, xpoint, main_v_1, main_a_1, main_v_2, main_a_2, pinp_v_1, pinp_a_1, pinp_v_2, pinp_a_2, pinp_on_1, pinp_on_2 [↵]
	Response	@ECM, xpoint, main_v_1, main_a_1, main_v_2, main_a_2, pinp_v_1, pinp_a_1, pinp_v_2, pinp_a_2, pinp_on_1, pinp_on_2 [↵]
Parameter		<p>xpoint: Crosspoint memory 1 to 9</p> <p>main_v_1-2 : Video input channel of the OUT1/OUT2 main window main_a_1-2 : Audio input channel of the OUT1/OUT2 main window pinp_v_1-2 : Video input channel of the OUT1/OUT2 PinP window pinp_a_1-2 : Audio input channel of the OUT1/OUT2 PinP window -1 = Not control [Default], 0 = OFF, 1 to 7 = IN1 to IN7</p> <p>pinp_on_1-2: OUT1/OUT2 layout pattern -1 = Not control [Default], 0 = OFF, 1 = PinP PATTERN 1, 2 = PinP PATTERN 2, 3 = PinP PATTERN 3, 4 = PinP PATTERN 4, 5 = PinP PATTERN 5</p> <p>name: Crosspoint memory name Up to 10 characters from 20 to 7D from ASCII code [Default] 20 (space)</p>
Getting example		<p>@GCM,2 [↵] @GCM,2,3,3,4,4,0,-1,1,-1,0,1,XPS2 [↵]</p> <p>Getting the video/audio input channels and layout pattern of Crosspoint memory 2 Crosspoint memory name : XPS2 OUT1 main window : IN3 OUT1 PinP window : OFF OUT1 layout pattern : OFF OUT2 main window : IN4 OUT2 PinP window : IN1 OUT2 layout pattern : PinP PATTERN 1</p>
Setting example		<p>@ECM,2,-1,-1,-1,-1,-1,-1,-1,-1,0,0 [↵] @ECM,2,-1,-1,-1,-1,-1,-1,-1,-1,0,0 [↵]</p> <p>Editing the OUT1 and OUT2 of Crosspoint memory 2 to: main window and PinP window are set to "-1" (Not control), and "0" (PinP disabled). Completed</p>
Remarks		An error is returned if a value other than "-1" (Not control) or "0" (disabled) is set for PinP window audio input channel.

@GCV / @ECV		Editing crosspoint memory (Setting video input channel)
Getting	Command	@GCV, xpoint ↵
	Response	@GCV, xpoint, main_v_1, main_v_2, pinp_v_1, pinp_v_2, pinp_on_1, pinp_on_2, name ↵
Setting	Command	@ECV, xpoint, main_v_1, main_v_2, pinp_v_1, pinp_v_2, pinp_on_1, pinp_on_2 ↵
	Response	@ECV, xpoint, main_v_1, main_v_2, pinp_v_1, pinp_v_2, pinp_on_1, pinp_on_2 ↵
Parameter		<p>xpoint: Crosspoint memory 1 to 9</p> <p>main_v_1-2 : Video input channel of the OUT1/OUT2 main window pinp_v_1-2 : Video input channel of the OUT1/OUT2 PinP window -1 = Not control [Default], 0 = OFF, 1 to 7 = IN1 to IN7</p> <p>pinp_on_1-2: OUT1/OUT2 layout pattern -1 = Not control [Default], 0 = OFF, 1 = PinP PATTERN 1, 2 = PinP PATTERN 2, 3 = PinP PATTERN 3, 4 = PinP PATTERN 4, 5 = PinP PATTERN 5</p> <p>name: Crosspoint memory name Up to 10 characters from 20 to 7D from ASCII code [Default] 20 (space)</p>
Getting example		<p>@GCV,2 ↵ @GCV,2,3,4,-1,1,0,1,XPS2 ↵</p> <p>Getting the video input channel and layout pattern of Crosspoint memory 2 Crosspoint memory name : XPS2 OUT1 main window : IN3 OUT1 PinP window : Not control OUT1 layout pattern : OFF OUT2 main window : IN4 OUT2 PinP window : IN1 OUT2 layout pattern : PinP PATTERN 1</p>
Setting example		<p>@ECV,2,-1,-1,-1,-1,0,0 ↵ @ECV,2,-1,-1,-1,-1,0,0 ↵</p> <p>Editing the OUT1 and OUT2 of Crosspoint memory 2 to: main window and PinP window are set to "-1" (Not control), and "0" (PinP disabled). Completed</p>
Remarks		—

@GCA / @ECA		Editing crosspoint memory (Setting audio input channel)
Getting	Command	@GCA, xpoint ↵
	Response	@GCA, xpoint, main_a_1, main_a_2, name ↵
Setting	Command	@ECA, xpoint, main_a_1, main_a_2 ↵
	Response	@ECA, xpoint, main_a_1, main_a_2 ↵
Parameter		xpoint: Crosspoint memory 1 to 9
		main_a_1-2: OUT1/OUT2 audio input channel -1 = Not control [Default], 0 = OFF, 1 to 7 = IN1 to IN7
		name: Crosspoint memory name Up to 10 characters from 20 to 7D from ASCII code [Default] 20 (space)
Getting example		@GCA,2 ↵ @GCA,2,3,4,XPS2 ↵
		Getting the audio input channel of Crosspoint memory 2 Crosspoint memory name : XPS2 OUT1 audio input channel : IN3 OUT2 audio input channel : IN4
Setting example		@ECA,2,1,1 ↵ @ECA,2,1,1 ↵
		Setting the OUT1 and OUT2 Crosspoint memory 2 to audio channel IN1 Completed
Remarks		—

@RPM		Recalling preset memory
Setting	Command	@RPM, preset ↵
	Response	@RPM, preset ↵
Parameter		preset: Preset memory 1 to 8
Setting example		@RPM,3 ↵ @RPM,3 ↵
		Recalling Preset memory 3 Completed
Remarks		Once preset memory is recalled, all settings of video and audio I/O except for some environmental settings will be updated.

@SPM		Saving preset memory
Setting	Command	@SPM, preset (, name) ↵
	Response	@SPM, preset (, name) ↵
Parameter		preset: Preset memory 1 to 8 name: Preset memory name Up to 10 characters from 20 to 7D from ASCII code If you skip this parameter (“name”), only other settings are saved without changing its name.
Setting example		@SPM,2 ↵ @SPM,2 ↵
		Saving the current settings in Preset memory 2 without changing the memory name Completed
Setting example		@SPM,2,MEM2 ↵ @SPM,2,MEM2 ↵
		Saving the current settings in Preset memory 2 with the name of “MEM2” Completed
Remarks		All settings of video and audio I/O except for some environmental settings will be updated.









@GMU / @SMU		Start-up settings
Getting	Command	@GMU ↵
	Response	@GMU, state ↵
Setting	Command	@SMU, state ↵
	Response	@SMU, state ↵
Parameter		state: Start-up settings 1 to 9 = Crosspoint memory 1 to 9, 10 = Channel OFF, 11 = Last channel [Default], 12 to 19 = Preset memory 1 to 8
Getting example		@GMU ↵ @GMU,3 ↵
		Getting the start-up I/O channels Starts with the channel settings saved in Crosspoint memory 3
Setting example		@SMU,3 ↵ @SMU,3 ↵
		Setting the start-up I/O channels to Crosspoint memory 3 Completed
Remarks		—

3.3.18 Bitmap

@GBM / @SBM		Bitmap output
Getting	Command	@GBM ↵
	Response	@GBM, bitmap_main_1, bitmap_main_2, bitmap_pinp_1, bitmap_pinp_2 ↵
Setting	Command	@SBM, output, bitmap (, output, bitmap···) ↵
	Response	@SBM, output, bitmap (, output, bitmap···) ↵
Parameter		<p>output: Output channel 0 = All outputs, 1 = OUT1 main window, 2 = OUT2 main window, 201 = OUT1 PinP window, 202 = OUT2 PinP window</p> <p>bitmap_main_1-2 : Bitmap output of the OUT1/OUT2 main window bitmap_pinp_1-2 : Bitmap output of the OUT1/OUT2 PinP window bitmap : Bitmap output 0 = OFF [Default], 1 = Bitmap 1, 2 = Bitmap 2, 3 = Bitmap 3, 4 = Bitmap 4 Only saved numbers can be specified.</p>
Getting example		<p>@GBM ↵ @GBM,1, 0,0,0 ↵</p> <p>Getting the bitmap output OUT1 main window : Bitmap 1 Other windows : Not output a bitmap</p>
Setting example		<p>@SBM,1,1 ↵ @SBM,1,1 ↵</p> <p>Outputting Bitmap 1 to the OUT1 main window Completed</p>
Remarks		Bitmap is displayed on entire main window.

@GBB / @SBB		Background color
Getting	Command	@GBB, output
	Response	@GBB, output, red, green, blue (, red, green, blue···)
Setting	Command	@SBB, output, bitmap, red, green, blue (, output, bitmap, red, green, blue···)
	Response	@SBB, output, bitmap, red, green, blue (, output, bitmap, red, green, blue···)
Parameter		<p>output: Output channel 0 = All outputs (For setting only), 1 = OUT1 main window, 2 = OUT2 main window</p> <p>bitmap: Bitmap number 0 = All bitmaps, 1 = Bitmap 1, 2 = Bitmap 2, 3 = Bitmap 3, 4 = Bitmap 4 Only saved numbers can be specified.</p> <p>red : Background color (Red) green : Background color (Green) blue : Background color (Blue) 0 to 255 [Default] 255 (White)</p>
Getting example		<p>@GBB,1 </p> <p>@GBB,1,255,0,0 </p> <p>Getting the background color of the bitmap displayed on the OUT1 main window R : 255 G and B : 0 (Red) If multiple bitmaps are saved, the setting value can be gain in bitmap numerical order.</p>
Setting example		<p>@SBB,1,1,255,255,255 </p> <p>@SBB,1,1,255,255,255 </p> <p>Setting the background color for when Bitmap 1 is output to the OUT1 main window to "255" (White) for all (RGB) Completed</p>
Remarks		Bitmap is displayed on entire main window.

@GBT / @SBT		Aspect ratio
Getting	Command	@GBT, output
	Response	@GBT, output, aspect (, aspect···)
Setting	Command	@SBT, output, bitmap, aspect (, output, bitmap, aspect···)
	Response	@SBT, output, bitmap, aspect (, output, bitmap, aspect···)
Parameter		output: Output channel 0 = All outputs (For setting only), 1 = OUT1 main window, 2 = OUT2 main window, 201 = OUT1 PinP window, 202 = OUT2 PinP window
		bitmap: Bitmap number 0 = All bitmaps, 1 = Bitmap 1, 2 = Bitmap 2, 3 = Bitmap 3, 4 = Bitmap 4 Only saved numbers can be specified.
		aspect_1-4 : Bitmap 1 to 4 aspect ratio aspect : Aspect ratio 0 = AUTO [Default], 1 = FULL, 2 = THROUGH
Getting example	@GBT,1	
	@GBT,1,1,1,1,1	
		Getting the aspect ratio of the bitmap displayed on the OUT1 main window Displayed on FULL screen If multiple bitmaps are saved, the setting value can be gain in bitmap numerical order.
Setting example	@SBT,1,1,1	
	@SBT,1,1,1	
		Setting the aspect ratio of Bitmap 1 that is output to the OUT1 main window to FULL Completed
Remarks	Bitmap is displayed on entire main window.	

@GZP / @SZP		Image position
Getting	Command	@GZP, output 
	Response	@GZP, output, position (, position···) 
Setting	Command	@SZP, output, bitmap, position (, output, bitmap, position···) 
	Response	@SZP, output, bitmap, position (, output, bitmap, position···) 
Parameter		output: Output channel 0 = All outputs (For setting only), 1 = OUT1 main window, 2 = OUT2 main window
		bitmap: Bitmap number 0 = All bitmaps, 1 = Bitmap 1, 2 = Bitmap 2, 3 = Bitmap 3, 4 = Bitmap 4 Only saved numbers can be specified.
		position: Image position 0 = CENTER [Default], 1 = TOP-LEFT, 2 = BOTTOM-LEFT, 3 = TOP-RIGHT, 4 = BOTTOM-RIGHT
Getting example		@GZP,1  @GZP,1,1 
		Getting the image position of the bitmap displayed on the OUT1 main window TOP-LEFT If multiple bitmaps are saved, the setting value can be gain in bitmap numerical order.
Setting example		@SZP,1,1,1  @SZP,1,1,1 
		Setting Bitmap 1 (that is output to the OUT1 main window) to be displayed in the upper left Completed
Remarks		Bitmap is displayed on entire main window.

@GBA / @SBA		Assigning input channel
Getting	Command	@GBA, output
	Response	@GBA, output, bitmap_1, bitmap_2, bitmap_3, bitmap_4, bitmap_5, bitmap_6, bitmap_7, bitmap_8
Setting	Command	@SBA, output, input, bitmap (, output, input, bitmap···)
	Response	@SBA, output, input, bitmap (, output, input, bitmap···)
Parameter		<p>output: Output channel 0 = All outputs (For setting only), 1 = OUT1 main window, 2 = OUT2 main window, 201 = OUT1 PinP window, 202 = OUT2 PinP window</p> <p>input: Input channel MSD-S71/S72 : 0 = All inputs, 1 to 7 = IN1 to IN7, 8 = OFF MSD-S51/S52 : 0 = All inputs, 1 to 5 = IN1 to IN5, 6 = OFF</p> <p>bitmap_1-8 : IN1 to IN7, OFF bitmap assignment bitmap : Bitmap assignment 0 = OFF [Default], 1 = Bitmap 1, 2 = Bitmap 2, 3 = Bitmap 3, 4 = Bitmap 4 Only saved numbers can be specified.</p>
Getting example		<p>@GBA,1 </p> <p>@GBA,1,0,0,0,0,0,0,1,1 </p> <p>Getting the bitmap assignment of input channel selected in the OUT1 main window OUT1 main window : Bitmap 1 to IN7 and OFF Other input channels: No bitmap is assigned.</p>
Setting example		<p>@SBA,1,7,1 </p> <p>@SBA,1,7,1 </p> <p>Setting Bitmap 1 assigned to IN7 to be output to the OUT1 main window. Completed</p>
Remarks		Bitmap is displayed on entire main window.

@GPB / @SPB		Start-up bitmap output
Getting	Command	@GPB ↵
	Response	@GPB, bitmap_main_1, bitmap_main_2, bitmap_pinp_1, bitmap_pinp_2 ↵
Setting	Command	@SPB, output, bitmap (, output, bitmap···) ↵
	Response	@SPB, output, bitmap (, output, bitmap···) ↵
Parameter		output: Output channel 0 = All outputs, 1 = OUT1 main window, 2 = OUT2 main window, 201 = OUT1 PinP window, 202 = OUT2 PinP window
		bitmap_main_1-2 : Bitmap output of the OUT1/OUT2 main window bitmap_pinp_1-2 : Bitmap output of the OUT1/OUT2 PinP window bitmap : Bitmap output 0 = OFF [Default], 1 = Bitmap 1, 2 = Bitmap 2, 3 = Bitmap 3, 4 = Bitmap 4 Only saved numbers can be specified.
Getting example		@GPB ↵ @GPB,0,1,2,3 ↵
		Getting the start-up bitmap output OUT1 main window : Not output a bitmap OUT2 main window : Bitmap 1 OUT1 PinP window : Bitmap 2 OUT2 PinP window : Bitmap 3
Setting example		@SPB,0,1 ↵ @SPB,0,1 ↵
		Setting Bitmap 1 to be output to all output channels when the MSD-S is powered on Completed
Remarks		Bitmap is displayed on entire main window.

@GBD / @SBD		Dividing memory area
Getting	Command	@GBD
	Response	@GBD, num, block_1 (, block_2···)
Setting	Command	@SBD, num, mode (, block_1, block_2···)
	Response	@SBD, num, mode, block_1 (, block_2···)
Parameter		<p>num: The number of partitions 1 to 4 [Default] 1</p> <p>mode: Dividing mode 0 = AUTO, 1 = RESIZE, 2 = FORCE, 3 = Specify size If "3" is selected, set the value for "block_1-4".</p> <p>block_1-4: Block size of each memory 0 to 128 [Default] 128 Specify and return the divided block size. 1 block : 65,536 bytes The total size of all bitmaps : 128 blocks (8,388,608 bytes) or smaller Specify only if "3" is selected for the "mode" below. If the divide mode is set to "3", specify this value.</p>
Getting example		<p>@GBD </p> <p>@GBD,2,64,64 </p> <p>Getting the dividing memory area for bitmap Bitmap 1 and 2: 64 blocks (4,194,304 bytes) are allocated for each.</p>
Setting example		<p>@SBD,2,1 </p> <p>@SBD,2,1,64,64 </p> <p>Dividing the bitmap memory into two in RESIZE Bitmap 1 and 2: 64 blocks (4,194,304 bytes) are allocated for each. Completed</p>
Remarks		Up to four images in total for bitmap and overlay bitmap can be saved.

@GBV		Memory area status
Getting	Command	@GBV
	Response	@GBV, num, block_1 (, block_2···)
Parameter		<p>num: The number of partitions 1 to 4 [Default] 1</p> <p>block_1-4: Block size of each memory actually used 0 to 128 [Default] 12</p>
Getting example		<p>@GBV </p> <p>@GBV,2,32,0 </p> <p>Getting the actual memory area status Bitmap 1 : 32 blocks (2,097,152 bytes) are used Bitmap 2 : Not saved</p>
Remarks		—

@GFZ / @SFZ		Freeze
Getting	Command	@GFZ [↵]
	Response	@GFZ, freeze_1, freeze_2 [↵]
Setting	Command	@SFZ, output, freeze (, output, freeze) [↵]
	Response	@SFZ, output, freeze (, output, freeze) [↵]
Parameter		output: Output channel 0 = All outputs, 1 = OUT1 main window, 2 = OUT2 main window freeze_1-2 : OUT1/ OUT2 setting freeze freeze : Setting freeze 0 = OFF [Default], 1 = ON
Getting example		@GFZ [↵] @GFZ,1,0 [↵] Getting the freeze status OUT1 main window: Input video is frozen and output.
Setting example		@SFZ,1,1 [↵] @SFZ,1,1 [↵] Freezing the video of the OUT1 main window Completed
Remarks		When input channel is switched, the freeze is released automatically.

@CAP		Output image capture
Setting	Command	@CAP, output, bitmap [↵]
	Response	@CAP, output, bitmap [↵]
Parameter		output: Output channel 1 = OUT1 main window, 2 = OUT2 main window bitmap: Bitmap number 1 = Bitmap 1, 2 = Bitmap 2, 3 = Bitmap 3, 4 = Bitmap 4 Only the number of partitions or less value can be specified.
Setting example		@CAP,1,2 [↵] @CAP,1,2 [↵] Saving the output image of the OUT1 main window in Bitmap 2 Completed
Remarks		—

3.3.19 Overlay bitmap

@GZM / @SZM		Overlay bitmap output
Getting	Command	@GZM ↵
	Response	@GZM, bitmap_1, bitmap_2 ↵
Setting	Command	@SZM, output, bitmap (, output, bitmap···) ↵
	Response	@SZM, output, bitmap (, output, bitmap···) ↵
Parameter		<p>output: Output channel 0 = All outputs, 1 = OUT1, 2 = OUT2</p> <p>bitmap_1-2 : OUT1/OUT2 overlay bitmap output bitmap : Overlay bitmap output 0 = OFF [Default], 1 = Bitmap 1, 2 = Bitmap 2, 3 = Bitmap 3, 4 = Bitmap 4 Only saved numbers can be specified.</p>
Getting example		<p>@GZM ↵ @GZM,1, 0 ↵</p> <p>Getting the overly bitmap output OUT1 : Bitmap 1 OUT2 : Not output an overlay bitmap</p>
Setting example		<p>@SZM,1,1 ↵ @SZM,1,1 ↵</p> <p>Outputting the Bitmap 1 overlay bitmap to OUT1 Completed</p>
Remarks		—

@GZO / @SZO		Image position
Getting	Command	@GZO, output
	Response	@GZO, output, position (, position···)
Setting	Command	@SZO, output, bitmap, position (, output, bitmap, position···)
	Response	@SZO, output, bitmap, position (, output, bitmap, position···)
Parameter		output: Output channel 0 = All outputs, 1 = OUT1, 2 = OUT2
		bitmap: Bitmap number 0 = All bitmaps, 1 = Bitmap 1, 2 = Bitmap 2, 3 = Bitmap 3, 4 = Bitmap 4 Only saved numbers can be specified.
		position: Image position 0 = CENTER [Default], 1 = TOP-LEFT, 2 = BOTTOM-LEFT, 3 = TOP-RIGHT, 4 = BOTTOM-RIGHT
Getting example		@GZO,1 @GZO,1,1
		Getting the image position of the OUT1 overlay bitmap TOP-LEFT If multiple overlay bitmaps are saved, the setting value can be gain in bitmap numerical order.
Setting example		@SZO,1,1,1 @SZO,1,1,1
		Setting the Bitmap 1 overlay bitmap (that is output to OUT1) to be displayed in the upper left Completed
Remarks		—

@GZT / @SZT		Transparency
Getting	Command	@GZT, output ↵
	Response	@GZT, output, transparency, red, green, blue (, transparency, red, green, blue···) ↵
Setting	Command	@SZT, output, bitmap, transparency, red, green, blue (, output, bitmap, transparency, red, green, blue···) ↵
	Response	@SZT, output, bitmap, transparency, red, green, blue (, output, bitmap, transparency, red, green, blue···) ↵
Parameter		output: Output channel 0 = All outputs, 1 = OUT1, 2 = OUT2
		bitmap: Bitmap number 0 = All bitmaps, 1 = Bitmap 1, 2 = Bitmap 2, 3 = Bitmap 3, 4 = Bitmap 4 Only saved numbers can be specified.
		transparency: Transparency 0 = OFF [Default], 1 = ON
		red : Transparency color (Red) green : Transparency color (Green) blue : Transparency color (Blue) 0 to 255 [Default] 0 (Black)
Getting example		@GZT,1 ↵ @GZT,1,1,255,255,255 ↵
		Getting the transparency color of the OUT1 overlay bitmap RGB: 255 (White) If multiple overlay bitmaps are saved, the setting value can be gain in bitmap numerical order.
Setting example		@SZT,1,1,1,255,255,255 ↵ @SZT,1,1,1,255,255,255 ↵
		Setting the color of the Bitmap 1 overlay bitmap that is output to OUT 1 to white (RGB: 255) Completed
Remarks		—

@GBL / @SBL		Blending
Getting	Command	@GBL, output ↵
	Response	@GBL, output, blend (, blend···) ↵
Setting	Command	@SBL, output, bitmap, blend (, output, bitmap, blend···) ↵
	Response	@SBL, output, bitmap, blend (, output, bitmap, blend···) ↵
Parameter		output: Output channel 0 = All outputs, 1 = OUT1, 2 = OUT2
		bitmap: Bitmap number 0 = All bitmaps, 1 = Bitmap 1, 2 = Bitmap 2, 3 = Bitmap 3, 4 = Bitmap 4 Only saved numbers can be specified.
		blend: Blending rate 0 to 100 [%] [Default] 100
Getting example		@GBL,1 ↵ @GBL,1,50 ↵
		Getting the blending rate of the OUT1 overlay bitmap 50% If multiple overlay bitmaps are saved, the setting value can be gain in bitmap numerical order.
Setting example		@SBL,1,1,50 ↵ @SBL,1,1,50 ↵
		Outputting the Bitmap 1 overlay bitmap to OUT1 with 50% blending rate Completed
Remarks		—

3.3.20 Configuring MSD-S

@GLS / @SLS		Front panel security lockout
Getting	Command	@GLS ↵
	Response	@GLS, lock ↵
Setting	Command	@SLS, lock ↵
	Response	@SLS, lock ↵
Parameter		lock: Front panel security lockout 0 = Unlocking [Default], 1 = Locking, 2 = Changing the current setting
Getting example	@GLS ↵	
	@GLS,1 ↵	
		Getting the lock status Locking
Setting example	@SLS,1 ↵	
	@SLS,1 ↵	
		Enabling the front panel security lockout Completed
Remarks		The security target can be set for each group separately. 【See: @GLM / @SLM Grouping front panel security lockout】

@GLM / @SLM		Grouping front panel security lockout
Getting	Command	@GLM ↵
	Response	@GLM, channel, menu, f_button, fn_button, standby ↵
Setting	Command	@SLM, channel, menu, f_button, fn_button, standby ↵
	Response	@SLM, channel, menu, f_button, fn_button, standby ↵
Parameter		channel : Input selection buttons menu : Menu operation button f_button : Function buttons fn_button : FN buttons standby : Standby button 0 = Not locked, 1 = Locked [Default]
Getting example	@GLM ↵	
	@GLM,1,0,0,0,0 ↵	
		Getting the button security lockout target Input selection buttons are locked.
Setting example	@SLM,1,0,0,0,0 ↵	
	@SLM,1,0,0,0,0 ↵	
		Setting the input selection buttons to be locked Completed
Remarks		—

@GBZ / @SBZ		Beep
Getting	Command	@GBZ ↵
	Response	@GBZ, bz ↵
Setting	Command	@SBZ, bz ↵
	Response	@SBZ, bz ↵
Parameter		bz: Beep 0 = OFF [Default], 1 = ON
Getting example	@GBZ ↵	
	@GBZ,1 ↵ Getting the beep status ON	
Setting example	@SBZ,1 ↵	
	@SBZ,1 ↵ Enabling beep Completed	
Remarks		—





3.3.21 Status

@GSS		Input signal and sink device status									
Getting	Command	@GSS, channel, mode ↵									
	Response	@GSS, channel, mode, status_1 (, status_2, status_3···) ↵									
Parameter	channel: I/O connectors 1 = IN1, 2 = IN2, 3 = IN3, 4 = IN4, 5 = IN5, 6 = IN6, 7 = IN7, 11 = HDMI OUT1A, 12 = HDBT OUT1B, 13 = HDMI OUT2A, 14 = HDBT OUT2B										
	mode: Target status channel = 1 to 7 (Digital input connector) 0 = All of 1 to 4, 1 = Input signal type*1, 2 = Video input signal format*2, 3 = Audio input signal format*3, 4 = Input signal HDCP*4 channel = 6 to 7 (Analog input connector) 0 = All of 1 to 2, 1 = Input signal type*1, 2 = Video input signal format*2 channel = 11 to 13 (Output connector) 0 = All of 1 to 3, 1 = HDCP authentication status*5, 2 = Output signal type*6, 3 = Error code*7										
	status_1-4: Status mode *1 Input signal type <table border="1" data-bbox="485 1339 1442 1541"> <tbody> <tr> <td>Hxx</td> <td>HDMI signal is input. xx stands for color depth (24 or 30).</td> </tr> <tr> <td>D</td> <td>DVI signal is input.</td> </tr> <tr> <td>R</td> <td>Analog RGB signal is input.</td> </tr> <tr> <td>Y</td> <td>Analog YPbPr signal is input.</td> </tr> <tr> <td>N</td> <td>No signal is input.</td> </tr> </tbody> </table>		Hxx	HDMI signal is input. xx stands for color depth (24 or 30).	D	DVI signal is input.	R	Analog RGB signal is input.	Y	Analog YPbPr signal is input.	N
Hxx	HDMI signal is input. xx stands for color depth (24 or 30).										
D	DVI signal is input.										
R	Analog RGB signal is input.										
Y	Analog YPbPr signal is input.										
N	No signal is input.										

@GSS	Input signal and sink device status (Cont'd)																										
Parameter	<p data-bbox="453 277 790 306">*2 Video input signal format</p> <table border="1" data-bbox="485 311 1441 667"> <thead> <tr> <th data-bbox="485 311 764 349">Example</th> <th data-bbox="764 311 1441 349">Description</th> </tr> </thead> <tbody> <tr> <td data-bbox="485 349 764 432">1080i 59.94Hz</td> <td data-bbox="764 349 1441 432">SDTV/HDTV signal is input, which returns the format type and vertical sync frequency.</td> </tr> <tr> <td data-bbox="485 432 764 551">800 x 600 60.00Hz</td> <td data-bbox="764 432 1441 551">RGB signal is input, and [Horizontal resolution × Vertical resolution] and vertical sync frequency are returned.</td> </tr> <tr> <td data-bbox="485 551 764 629">56.83kHz 60.02Hz</td> <td data-bbox="764 551 1441 629">Undetectable signal is input, which returns the horizontal and vertical sync frequencies.</td> </tr> <tr> <td data-bbox="485 629 764 667">NO SIGNAL</td> <td data-bbox="764 629 1441 667">No video signal is input.</td> </tr> </tbody> </table> <p data-bbox="453 714 790 743">*3 Audio input signal format</p> <table border="1" data-bbox="485 748 1441 1144"> <thead> <tr> <th data-bbox="485 748 764 786">Example</th> <th data-bbox="764 748 1441 786">Description</th> </tr> </thead> <tbody> <tr> <td data-bbox="485 786 764 869">LINEAR PCM 48kHz</td> <td data-bbox="764 786 1441 869">LPCM signal is input, which returns the sampling frequency.</td> </tr> <tr> <td data-bbox="485 869 764 947">LINEAR PCM 48kHz (MULTI CHANNEL)</td> <td data-bbox="764 869 1441 947">Multi-channel LPCM signal is input, which returns the sampling frequency.</td> </tr> <tr> <td data-bbox="485 947 764 1104">COMPRESSED AUDIO</td> <td data-bbox="764 947 1441 1104">Compressed audio signal (Such as Dolby Digital and DTS) is input (The MSD-S does not recognize detailed formats, "COMPRESSED AUDIO" is sent to all compressed audios).</td> </tr> <tr> <td data-bbox="485 1104 764 1144">NO SIGNAL</td> <td data-bbox="764 1104 1441 1144">No audio signal is input.</td> </tr> </tbody> </table> <p data-bbox="453 1191 715 1220">*4 Input signal HDCP</p> <table border="1" data-bbox="485 1225 1441 1346"> <thead> <tr> <th data-bbox="485 1225 764 1263">Example</th> <th data-bbox="764 1225 1441 1263">Description</th> </tr> </thead> <tbody> <tr> <td data-bbox="485 1263 764 1303">HDCP ON</td> <td data-bbox="764 1263 1441 1303">Signal with HDCP is input.</td> </tr> <tr> <td data-bbox="485 1303 764 1346">HDCP OFF</td> <td data-bbox="764 1303 1441 1346">Signal without HDCP is input.</td> </tr> </tbody> </table>	Example	Description	1080i 59.94Hz	SDTV/HDTV signal is input, which returns the format type and vertical sync frequency.	800 x 600 60.00Hz	RGB signal is input, and [Horizontal resolution × Vertical resolution] and vertical sync frequency are returned.	56.83kHz 60.02Hz	Undetectable signal is input, which returns the horizontal and vertical sync frequencies.	NO SIGNAL	No video signal is input.	Example	Description	LINEAR PCM 48kHz	LPCM signal is input, which returns the sampling frequency.	LINEAR PCM 48kHz (MULTI CHANNEL)	Multi-channel LPCM signal is input, which returns the sampling frequency.	COMPRESSED AUDIO	Compressed audio signal (Such as Dolby Digital and DTS) is input (The MSD-S does not recognize detailed formats, "COMPRESSED AUDIO" is sent to all compressed audios).	NO SIGNAL	No audio signal is input.	Example	Description	HDCP ON	Signal with HDCP is input.	HDCP OFF	Signal without HDCP is input.
Example	Description																										
1080i 59.94Hz	SDTV/HDTV signal is input, which returns the format type and vertical sync frequency.																										
800 x 600 60.00Hz	RGB signal is input, and [Horizontal resolution × Vertical resolution] and vertical sync frequency are returned.																										
56.83kHz 60.02Hz	Undetectable signal is input, which returns the horizontal and vertical sync frequencies.																										
NO SIGNAL	No video signal is input.																										
Example	Description																										
LINEAR PCM 48kHz	LPCM signal is input, which returns the sampling frequency.																										
LINEAR PCM 48kHz (MULTI CHANNEL)	Multi-channel LPCM signal is input, which returns the sampling frequency.																										
COMPRESSED AUDIO	Compressed audio signal (Such as Dolby Digital and DTS) is input (The MSD-S does not recognize detailed formats, "COMPRESSED AUDIO" is sent to all compressed audios).																										
NO SIGNAL	No audio signal is input.																										
Example	Description																										
HDCP ON	Signal with HDCP is input.																										
HDCP OFF	Signal without HDCP is input.																										

@GSS	Input signal and sink device status (Cont'd)																																																				
Parameter	<p data-bbox="451 277 823 306">*5 HDCP authentication status</p> <table border="1" data-bbox="485 311 1442 869"> <thead> <tr> <th data-bbox="485 311 767 349">Example</th> <th data-bbox="767 311 1442 349">Description</th> </tr> </thead> <tbody> <tr> <td data-bbox="485 349 767 394">HDCP SUPPORT</td> <td data-bbox="767 349 1442 394">Device with HDCP is connected.</td> </tr> <tr> <td data-bbox="485 394 767 472">HDCP NOT SUPPORT</td> <td data-bbox="767 394 1442 472">Device without HDCP is connected.</td> </tr> <tr> <td data-bbox="485 472 767 551">HDCP ERROR</td> <td data-bbox="767 472 1442 551">Device with HDCP is connected, but the authorization failed.</td> </tr> <tr> <td data-bbox="485 551 767 629">HDCP CHECK NOW</td> <td data-bbox="767 551 1442 629">Connection status of sink device was changed, and the status is being checked.</td> </tr> <tr> <td data-bbox="485 629 767 707">SINK DEVICE DISCONNECT</td> <td data-bbox="767 629 1442 707">Sink device is disconnected.</td> </tr> <tr> <td data-bbox="485 707 767 786">HDBaseT LINK DISCONNECT</td> <td data-bbox="767 707 1442 786">HDBaseT output cable is disconnected.</td> </tr> <tr> <td data-bbox="485 786 767 831">HDBaseT NO LINK</td> <td data-bbox="767 786 1442 831">HDBaseT output cable is not connected.</td> </tr> <tr> <td data-bbox="485 831 767 869">UNCONNECTED</td> <td data-bbox="767 831 1442 869">Sink device is not connected.</td> </tr> </tbody> </table> <p data-bbox="451 913 708 943">*6 Output signal type</p> <table border="1" data-bbox="485 947 1442 1151"> <tbody> <tr> <td data-bbox="485 947 632 992">Hxx</td> <td data-bbox="632 947 1442 992">HDMI signal is output. xx stands for the color depth (24).</td> </tr> <tr> <td data-bbox="485 992 632 1037">D</td> <td data-bbox="632 992 1442 1037">DVI signal is input.</td> </tr> <tr> <td data-bbox="485 1037 632 1081">C</td> <td data-bbox="632 1037 1442 1081">HDCP is being authorized. No video is output.</td> </tr> <tr> <td data-bbox="485 1081 632 1126">N</td> <td data-bbox="632 1081 1442 1126">No sink device is connected.</td> </tr> <tr> <td data-bbox="485 1126 632 1151">O</td> <td data-bbox="632 1126 1442 1151">No category cable is connected.</td> </tr> </tbody> </table> <p data-bbox="451 1196 1126 1225">*7 Error codes below are returned in the following order: Video/Audio output, and analog audio output</p> <p data-bbox="491 1270 619 1299">Error code</p> <table border="1" data-bbox="485 1303 1442 2018"> <thead> <tr> <th data-bbox="485 1303 632 1382">Error code</th> <th data-bbox="632 1303 1038 1382">Video output status</th> <th data-bbox="1038 1303 1442 1382">Audio output status</th> </tr> </thead> <tbody> <tr> <td data-bbox="485 1382 632 1426">0</td> <td colspan="2" data-bbox="632 1382 1442 1426">Video or audio is output correctly.</td> </tr> <tr> <td data-bbox="485 1426 632 1550">1</td> <td data-bbox="632 1426 1038 1550">"@GVO / @SVO Output signal" is set to "Outputs black".</td> <td data-bbox="1038 1426 1442 1550">"@GAM / @SAM Audio mute" is set to "ON".</td> </tr> <tr> <td data-bbox="485 1550 632 1673">2</td> <td colspan="2" data-bbox="632 1550 1442 1673">Only digital input is returned, which means DDC power is not input. (When no source device is connected, this error code is normally displayed.)</td> </tr> <tr> <td data-bbox="485 1673 632 1718">3</td> <td data-bbox="632 1673 1038 1718">No video signal is input.</td> <td data-bbox="1038 1673 1442 1718">No audio signal is input.*8</td> </tr> <tr> <td data-bbox="485 1718 632 1785">4</td> <td colspan="2" data-bbox="632 1718 1442 1785">Only digital input is returned, which means video or audio output of the source device is muted.</td> </tr> <tr> <td data-bbox="485 1785 632 1908">5</td> <td colspan="2" data-bbox="632 1785 1442 1908">Only digital input is returned, which means signal with HDCP is input but sink device is HDCP incompliant (This error code may be also returned during HDCP authentication)</td> </tr> <tr> <td data-bbox="485 1908 632 2018">6</td> <td colspan="2" data-bbox="632 1908 1442 2018">Only digital input is returned, which means source device does not output the returned information (packets) for output of video or audio.</td> </tr> </tbody> </table>	Example	Description	HDCP SUPPORT	Device with HDCP is connected.	HDCP NOT SUPPORT	Device without HDCP is connected.	HDCP ERROR	Device with HDCP is connected, but the authorization failed.	HDCP CHECK NOW	Connection status of sink device was changed, and the status is being checked.	SINK DEVICE DISCONNECT	Sink device is disconnected.	HDBaseT LINK DISCONNECT	HDBaseT output cable is disconnected.	HDBaseT NO LINK	HDBaseT output cable is not connected.	UNCONNECTED	Sink device is not connected.	Hxx	HDMI signal is output. xx stands for the color depth (24).	D	DVI signal is input.	C	HDCP is being authorized. No video is output.	N	No sink device is connected.	O	No category cable is connected.	Error code	Video output status	Audio output status	0	Video or audio is output correctly.		1	"@GVO / @SVO Output signal" is set to "Outputs black".	"@GAM / @SAM Audio mute" is set to "ON".	2	Only digital input is returned, which means DDC power is not input. (When no source device is connected, this error code is normally displayed.)		3	No video signal is input.	No audio signal is input.*8	4	Only digital input is returned, which means video or audio output of the source device is muted.		5	Only digital input is returned, which means signal with HDCP is input but sink device is HDCP incompliant (This error code may be also returned during HDCP authentication)		6	Only digital input is returned, which means source device does not output the returned information (packets) for output of video or audio.	
Example	Description																																																				
HDCP SUPPORT	Device with HDCP is connected.																																																				
HDCP NOT SUPPORT	Device without HDCP is connected.																																																				
HDCP ERROR	Device with HDCP is connected, but the authorization failed.																																																				
HDCP CHECK NOW	Connection status of sink device was changed, and the status is being checked.																																																				
SINK DEVICE DISCONNECT	Sink device is disconnected.																																																				
HDBaseT LINK DISCONNECT	HDBaseT output cable is disconnected.																																																				
HDBaseT NO LINK	HDBaseT output cable is not connected.																																																				
UNCONNECTED	Sink device is not connected.																																																				
Hxx	HDMI signal is output. xx stands for the color depth (24).																																																				
D	DVI signal is input.																																																				
C	HDCP is being authorized. No video is output.																																																				
N	No sink device is connected.																																																				
O	No category cable is connected.																																																				
Error code	Video output status	Audio output status																																																			
0	Video or audio is output correctly.																																																				
1	"@GVO / @SVO Output signal" is set to "Outputs black".	"@GAM / @SAM Audio mute" is set to "ON".																																																			
2	Only digital input is returned, which means DDC power is not input. (When no source device is connected, this error code is normally displayed.)																																																				
3	No video signal is input.	No audio signal is input.*8																																																			
4	Only digital input is returned, which means video or audio output of the source device is muted.																																																				
5	Only digital input is returned, which means signal with HDCP is input but sink device is HDCP incompliant (This error code may be also returned during HDCP authentication)																																																				
6	Only digital input is returned, which means source device does not output the returned information (packets) for output of video or audio.																																																				

@GSS	Input signal and sink device status (Cont'd)																																
Parameter	<table border="1" data-bbox="483 271 1441 1178"> <thead> <tr> <th data-bbox="483 271 632 349">Error code</th> <th data-bbox="632 271 1035 349">Video output status</th> <th data-bbox="1035 271 1441 349">Audio output status</th> </tr> </thead> <tbody> <tr> <td data-bbox="483 349 632 548">7</td> <td data-bbox="632 349 1035 548">Signal that is not supported by MSD-S (Dot clock is out of range) is input.</td> <td data-bbox="1035 349 1441 548">Since compressed audio is input, audio cannot be output (Compressed audio can be output only to sink devices supporting compressed audio).</td> </tr> <tr> <td data-bbox="483 548 632 624">8</td> <td data-bbox="632 548 1035 624">—</td> <td data-bbox="1035 548 1441 624">"@GUC / @SUC Output audio" is set to "Not output".</td> </tr> <tr> <td data-bbox="483 624 632 781">9</td> <td data-bbox="632 624 1035 781">—</td> <td data-bbox="1035 624 1441 781">"@GDM / @SDM Output format" is set to "DVI MODE" or a sink device that does not support audio is connected.*8</td> </tr> <tr> <td data-bbox="483 781 632 978">A</td> <td colspan="2" data-bbox="632 781 1441 978">Input channel is set to "OFF". (@GSW / @SSW Switching video and audio channel simultaneously, @GSV / @SSV Switching video channel, @GSA / @SSA Switching audio channel)</td> </tr> <tr> <td data-bbox="483 978 632 1016">B</td> <td data-bbox="632 978 1035 1016">—</td> <td data-bbox="1035 978 1441 1016">—</td> </tr> <tr> <td data-bbox="483 1016 632 1055">C</td> <td colspan="2" data-bbox="632 1016 1441 1055">No sink device is connected.</td> </tr> <tr> <td data-bbox="483 1055 632 1093">D</td> <td colspan="2" data-bbox="632 1055 1441 1093">HDCP is being authorized.</td> </tr> <tr> <td data-bbox="483 1093 632 1131">E</td> <td colspan="2" data-bbox="632 1093 1441 1131">HDCP authentication failed.</td> </tr> <tr> <td data-bbox="483 1131 632 1178">F</td> <td colspan="2" data-bbox="632 1131 1441 1178">No category cable is connected.</td> </tr> </tbody> </table> <p data-bbox="451 1223 1441 1290">*8 Analog audio input status cannot be detected. Even if "0" is returned, audio may not be output with analog input selected.</p>			Error code	Video output status	Audio output status	7	Signal that is not supported by MSD-S (Dot clock is out of range) is input.	Since compressed audio is input, audio cannot be output (Compressed audio can be output only to sink devices supporting compressed audio).	8	—	"@GUC / @SUC Output audio" is set to "Not output".	9	—	"@GDM / @SDM Output format" is set to "DVI MODE" or a sink device that does not support audio is connected.*8	A	Input channel is set to "OFF". (@GSW / @SSW Switching video and audio channel simultaneously, @GSV / @SSV Switching video channel, @GSA / @SSA Switching audio channel)		B	—	—	C	No sink device is connected.		D	HDCP is being authorized.		E	HDCP authentication failed.		F	No category cable is connected.	
Error code	Video output status	Audio output status																															
7	Signal that is not supported by MSD-S (Dot clock is out of range) is input.	Since compressed audio is input, audio cannot be output (Compressed audio can be output only to sink devices supporting compressed audio).																															
8	—	"@GUC / @SUC Output audio" is set to "Not output".																															
9	—	"@GDM / @SDM Output format" is set to "DVI MODE" or a sink device that does not support audio is connected.*8																															
A	Input channel is set to "OFF". (@GSW / @SSW Switching video and audio channel simultaneously, @GSV / @SSV Switching video channel, @GSA / @SSA Switching audio channel)																																
B	—	—																															
C	No sink device is connected.																																
D	HDCP is being authorized.																																
E	HDCP authentication failed.																																
F	No category cable is connected.																																
Getting example	<pre data-bbox="451 1339 1230 1601"> @GSS,1,0 ↵ @GSS,1,0,H30,1080P 60Hz,LINEAR PCM 48kHz, HDCP ON ↵ Getting IN1 all statuses - Input signal type : 30-BIT COLOR HDMI signal - Video input signal : 1080P 60Hz - Audio input signal : LINEAR PCM 48kHz - HDCP : ON </pre>																																
Remarks	—																																

@GES		Viewing sink device EDID
Getting	Command	@GES, channel, mode 
	Response	@GES, channel, mode, status_1 (, status_2, status_3, status_4) 
Parameter		<p>channel: Output connector 1 = HDMI OUT1A, 2 = HDBT OUT1B, 3 = HDMI OUT2A, 4 = HDBT OUT2B</p> <p>mode: Target status 0 = All of 1 to 4, 1 = Monitor name, 2 = Resolution and dot clock, 3 = HDMI support status, sampling structure, and color depth*1, 4 = Audio support status and sampling frequency, bit length, the number of channels, and support status of compressed audio*2</p> <p>status_1-4: Status mode *1 For sink device that does not support HDMI, "DVI" is returned. For sink device that supports HDMI, "HDMI" is returned, and then supported sampling structures (RGB, YCbCr 4:2:2, and YCbCr 4:4:4 separated with "/") and supported color depths (24, 30, and 36, separated with "/") are returned in that order. *2 For sink device that does not support audio, "AUDIO NOT SUPPORT" is returned. For sink device that supports audio, "LINEAR PCM" is returned, and then supported sampling frequencies (32, 44.1, 48, 88.2, 96, 176.4, and 192, separated with "/"), bit length (16, 20, and 24, separated with "/"), the number of channels (one of 1 to 8), and "COMPRESSED AUDIO SUPPORT" (If compressed audio is supported) are returned in that order.</p>
Getting example		<p>@GES,1,0 </p> <p>@GES,1,0,MSD-S72,1920x1080 148.50MHz,DVI,AUDIO NOT SUPPORT </p> <p>Getting the EDID of the sink device connected to HDMI OUT1A</p> <ul style="list-style-type: none"> - Monitor name : MSD-S72 - Resolution : 1920x1080 - Dot clock : 148.50MHz - HDMI : Not supported - Audio : Not supported
Remarks		—

@GHC		System status
Getting	Command	@GHC ↵
	Response	@GHC, fan, temp ↵
Parameter		fan: Rotation speed 0 = Normal, 1 = Abnormal
		temp: Internal temperature status 0 = Normal, 1 = Abnormal
Getting example		@GHC ↵ @GHC,1,0 ↵
		Getting the system check result - Rotation speed : Abnormal - Internal temperature status : Normal
Remarks		—

@GIV		Device information
Getting	Command	@GIV ↵
	Response	@GIV, id, ver ↵
Parameter		id : Model number ver : Firmware version
Getting example		@GIV ↵ @GIV, MSD-S72,1.00.00 ↵
		Getting the product information Model number: MSD-S72; Firmware version: 1.00
Remarks		—

User Guide (Command Guide) of MSD-S Series

Ver.1.6.0

Issued on: 5 January 2026



Headquarters

IDK Corporation
7-9-1 Chuo, Yamato-shi, Kanagawa-pref.
242-0021 JAPAN
TEL: +81-46-200-0764 FAX: +81-46-200-0765

Email: idk_eng@idk.co.jp

URL: www.idkav.com

USA

IDK America Inc.
72 Grays Bridge Road Suite 1-C, Brookfield, CT 06804
TEL: +1-203-204-2445

Email: sales@gidkav.com

URL: www.idkav.com

Europe

IDK Europe GmbH
Lise-Meitner-Str. 6, D-40878 Ratingen
TEL: +49-2102-578-301-0

Email: info@idkav.eu

URL: www.idkav.com



Product information Support

Arvanics Corporation
7-9-1 Chuo, Yamato-shi, Kanagawa-pref.
242-0021 JAPAN
TEL: +81-46-259-6920 FAX: +81-46-259-6930

Email: info@arvanics.com

URL: www.arvanics.com

Information in this document is subject to change without notice.

©2021 IDK Corporation, all rights reserved. All trademarks mentioned are the property of their respective owners.