



## Digital Multi Switcher MSD-S Series

MSD-S51/MSD-S52/MSD-S71/MSD-S72

<User Guide>

Ver.1.7.0

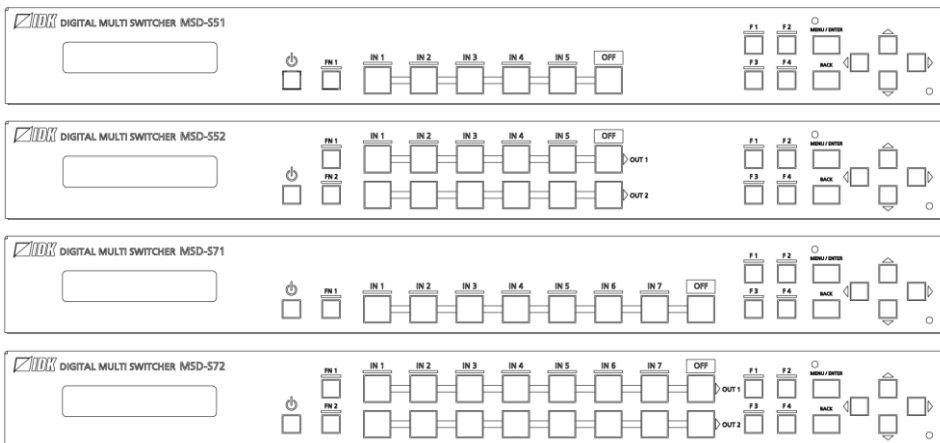

- Thank you for choosing our product.
- To ensure the best performance of this product, please read this user guide fully and carefully before using it and keep this manual together with the product for future reference as needed.

IDK Corporation

### **Trademarks**

- HDBaseT™ and the HDBaseT Alliance Logo are trademarks of the HDBaseT Alliance.
- The terms HDMI and HDMI High-Definition Multimedia Interface, and the HDMI Logo are trademarks or registered trademarks of HDMI Licensing Administrator, Inc. in the United States and other countries.
- SDVoE™ and SDVoE logo are trademarks of SDVoE Alliance.
- All other company and product names mentioned in this document are either registered trademarks or trademarks of their respective owners. In this document, the “®” or “™” marks may not be specified.
- ©2021 IDK Corporation, all rights reserved.

## Before reading this manual

- All rights reserved.
- Some information contained in this User guide such as exact product appearance, diagrams, menu operations, and so on may differ depending on the product version.
- This User guide is subject to change without notice. You can download the latest version from IDK's website at: [www.idkav.com](http://www.idkav.com)

The reference manual consists of the following two volumes:

- User guide (this document):  
Provides explanations and procedures for operations, installation, connections among devices, I/O adjustment and settings.
- Command guide: Please download the command guide from the website above.  
Provides explanations and procedures for external control using RS-232C and LAN communications.

#### FCC STATEMENT

**Note:** This equipment has been tested and found to comply with the limits for a Class A digital device, pursuant to part 15 of the FCC Rules. These limits are designed to provide reasonable protection against harmful interference when the equipment is operated in a commercial environment. This equipment generates, uses, and can radiate radio frequency energy and, if not installed and used in accordance with the instruction manual, may cause harmful interference to radio communications. Operation of this equipment in a residential area is likely to cause harmful interference, in which case the user will be required to correct the interference at his own expense.

(Class A)

#### Supplier's Declaration of Conformity 47 CFR § 2.1077 Compliance Information

##### Unique Identifier

Type of Equipment: DIGITAL MULTI SWITCHER  
Model Name: MSD-S51, MSD-S52, MSD-S71, MSD-S72

##### Responsible Party – U.S. Contact Information

Company Name: IDK America Inc.  
Address: 72 Grays Bridge Road Suite 1-C, Brookfield, CT 06804  
Telephone number: +1-203-204-2445  
URL: www.idkav.com

##### FCC Compliance Statement

This device complies with Part 15 of the FCC Rules. Operation is subject to the following two conditions: (1) This device may not cause harmful interference, and (2) this device must accept any interference received, including interference that may cause undesired operation.

(FCC SDoC)

#### CE MARKING

This equipment complies with the essential requirements of the relevant European health, safety and environmental protection legislation.

#### WEEE MARKING



Waste Electrical and Electronic Equipment (WEEE), Directive 2002/96/EC

(This directive is only valid in the EU.)



This equipment complies with the WEEE Directive (2002/96/EC) marking requirement.







The left marking indicates that you must not discard this electrical/electronic equipment in domestic household waste.

# Safety Instructions

Read all safety and operating instructions before using this product. Follow instructions and heed warnings/cautions.

Instructions and warnings/cautions for all products are provided. Some of them may not be applicable to your product.

	<b>Warning</b>	Indicates the presence of a hazard that may result in death or serious personal injury if the warning is ignored or the product is handled incorrectly.
	<b>Caution</b>	Indicates the presence of a hazard that may cause minor personal injury or property damage if the caution is ignored or the product is handled incorrectly.

Symbol	Description	Example
 Caution	This symbol is intended to alert the user. (Warning and caution)	 Hot surfaces Caution
 Prohibited	This symbol is intended to prohibit the user from specified actions.	 Do not disassemble
 Instruction	This symbol is intended to instruct the user.	 Unplug

## **Warning**

**For lifting heavy products:**

 Instruction	<ul style="list-style-type: none"> <li>• <b>Lifting must be done by two or more personnel.</b></li> </ul> <p>To avoid injury: When lifting the product, bend your knees, keep your back straight and get close to it with two or more persons.</p>
--	--





**For installing and connecting products:**

 Prohibited	<ul style="list-style-type: none"> <li>• <b>Do not place the product in unstable place.</b> Install the product in a horizontal and stable place, as this may fall or tip over and cause injury.</li> <li>• <b>Secure the product if installing in the locations with vibration.</b> Vibration may move or tip over the product unexpectedly, resulting in injury.</li> </ul>
---	---

## **Warning**

 <b>Instruction</b>	<ul style="list-style-type: none"> <li>• <b>Installation work must be performed by professionals.</b> The product is intended to be installed by skilled technicians. For installation, please contact a system integrator or IDK. Improper installation may lead to the risk of fire, electric shock, injury, or property damage.</li> <li>• <b>Insert the power plug into an outlet that is unobstructed.</b> Unobstructed access to the plug enables unplugging the product in case of any extraordinary failure, abnormal situation or for easy disconnection during extended periods of non-use.</li> <li>• <b>Insert the power plug into an appropriate outlet completely.</b> If the plug is partially inserted, arcing may cause the connection to overheat, increasing the risk of electric shock or fire. Do not use a damaged plug or connect to a loose outlet.</li> <li>• <b>Unplug the product from an AC power source during installation or service.</b> When connecting peripheral devices to this product, unplug all involved devices from outlets. Ground potential differences may cause fire or other difficulties.</li> <li>• <b>The product must be electrically earthed/grounded.</b> To reduce the risk of electric shock, ensure the product is connected to a mains socket outlet with a protective earthing connection.</li> <li>• <b>For powering/powered functions, compatible cables must be used.</b> Otherwise, it may cause problems or a fire.</li> </ul>
---	---

**For operating products:**

 <b>Prohibited</b>	<ul style="list-style-type: none"> <li>• <b>Keep out any foreign objects.</b> To avoid fire or electric shock, do not permit foreign objects, such as metal and paper, to enter the product from vent holes or other apertures.</li> <li>• <b>For power cables/plugs, AC adapters, and cables for powering/powered functions,</b> <ul style="list-style-type: none"> <li>• Do not scratch, heat, or modify, including splicing or lengthening them.</li> <li>• Do not pull, place heavy objects on them, or pinch them.</li> <li>• Do not bend, twist, tie or clamp them together forcefully.</li> </ul> </li> </ul> <p>Misuse of the power cable and plug may cause fire or electric shock. If power cables/plugs become damaged, contact your IDK representative.</p>
 <b>Do not disassemble</b>	<ul style="list-style-type: none"> <li>• <b>Do not repair, modify or disassemble.</b> Since the product includes circuitry that uses potentially lethal, high voltage levels, disassembly by unauthorized personnel may lead to the risk of fire or electric shock. For internal inspection or repair, contact your IDK representative.</li> </ul>
 <b>Do not touch</b>	<ul style="list-style-type: none"> <li>• <b>Do not touch the product and connected cables during electric storms.</b> Contact may cause electric shock.</li> </ul>
 <b>Instruction</b>	<ul style="list-style-type: none"> <li>• <b>Clean the power plug regularly.</b> If the plug is covered in dust, it may increase the risk of fire.</li> </ul>



**If the following problem occurs:**

 <b>Unplug</b>	<ul style="list-style-type: none"> <li>• <b>Unplug immediately if the product smokes, makes unusual noise, or produces a burning odor.</b></li> <li>• <b>Unplug immediately if the product is damaged by falling or having been dropped.</b></li> <li>• <b>Unplug immediately if water or other objects are directed inside.</b></li> </ul> <p>If you continue to use the product under these conditions, it may increase the risk of electric shock or fire. For maintenance and repair, contact your IDK representative.</p>
--	--







## Caution

### For installing and connecting products:

 <b>Prohibited</b>	<ul style="list-style-type: none"> <li>• <b>Do not place the product in a location where it will be subjected to high temperatures.</b> If the product is subjected to direct sunlight or high temperatures while under operation, it may affect the product's performance and reliability and may increase the risk of fire.</li> <li>• <b>Do not store or operate the product in dusty, oil smoke filled, or humid place.</b> Placing the product in such environment may increase the risk of fire or electric shock.</li> <li>• <b>Do not block the vent holes.</b> If ventilation slots are blocked, it may cause the product to overheat, affecting performance and reliability and may increase the risk of fire.</li> <li>• <b>Do not place or stack heavy items on the product.</b> Failure to observe this precaution may result in damage to the product itself as well as other property and may lead to the risk of personal injury.</li> <li>• <b>Do not exceed ratings of outlet and wiring devices.</b> Exceeding the rating of an outlet may increase the risk of fire and electric shock.</li> </ul>
 <b>No wet hands</b>	<ul style="list-style-type: none"> <li>• <b>Do not handle power plug with wet hands.</b> Failure to observe this precaution may increase the risk of electric shock.</li> </ul>
 <b>Instruction</b>	<ul style="list-style-type: none"> <li>• <b>Use and store the product within the specified temperature/humidity range.</b> If the product is used outside the specified range of temperature and humidity continuously, it may increase the risk of fire or electric shock.</li> <li>• <b>Do not place the product at elevations of 1.24 mi. (2,000 m) or higher above sea level.</b> Failure to do so may shorten the life of the internal parts and result in malfunctions.</li> <li>• <b>When mounting the product into the rack, provide sufficient cooling space.</b> Mount the product in a rack meeting EIA standards, and maintain spaces above and below for air circulation. For your safety as required, attach an L-shaped bracket in addition to the panel mount bracket kit to improve mechanical stability.</li> <li>• <b>Never insert screws without the rubber feet into the threaded holes on the bottom of the product.</b> Never insert screws alone into the threaded holes on the bottom of the product. Doing so may lead to damage when the screws contact electric circuitry or components inside the product. Reinstall the originally supplied rubber feet using the originally supplied screws only.</li> </ul>

**For operating products:**

 <p><b>Hot surfaces Caution</b></p>	<p><b>For products with the hot surfaces caution label only:</b></p> <ul style="list-style-type: none"> <li>• <b>Do not touch the product's hot surface.</b></li> </ul> <p>If the product is installed without enough space, it may cause malfunction of other products. If you touch product's hot surface, it may cause burns.</p>
 <p><b>Prohibited</b></p>	<ul style="list-style-type: none"> <li>• <b>Use only the supplied power cable and AC adapter.</b></li> <li>• <b>Do not use the supplied power cable and AC adapter with other products.</b></li> </ul> <p>If non-compliant adapter or power cables are used, it may increase the risk of fire or electric shock.</p>
 <p><b>Unplug</b></p>	<ul style="list-style-type: none"> <li>• <b>If the product won't be used for an extended period of time, unplug it.</b></li> </ul> <p>Failure to observe this precaution may increase the risk of fire.</p> <ul style="list-style-type: none"> <li>• <b>Unplug the product before cleaning.</b></li> </ul> <p>To prevent electric shock.</p>
 <p><b>Instruction</b></p>	<ul style="list-style-type: none"> <li>• <b>Do not prevent heat release.</b></li> </ul> <p>If cooling fan stops, power off the product and contact IDK. Failure to do so may raise internal temperature and increase the risk of malfunction, fire, or electric shock.</p> <ul style="list-style-type: none"> <li>• <b>Keep vents clear of dust.</b></li> </ul> <p>If the vent holes near the cooling fan or near the fan are covered with dust, internal temperatures increase and may increase the risk of malfunction. Clean the vent holes and near the fan as needed. If dust accumulates inside of the product, it may increase the risk of fire or electric shock. Periodic internal cleaning, especially before humid rainy season, is recommended. For internal cleaning, contact your IDK representative.</p>

## Table of Contents

1	Included items .....	14
2	About MSD-S .....	15
3	Features .....	16
4	Panels .....	17
4.1	Front/Side panels .....	17
4.2	Rear panel .....	18
5	System Configuration Example .....	19
6	Installation .....	20
6.1	Precautions .....	20
6.2	Rack mounting brackets .....	20
7	Connection Details .....	21
7.1	Precautions .....	21
7.2	Connecting video devices .....	21
7.2.1	Cable Lacing Bracket .....	22
7.2.2	HDBaseT output connector .....	22
7.2.3	Category cable .....	23
7.2.4	DVI-I input connector .....	24
7.3	Connecting audio device .....	25
7.3.1	Audio .....	25
7.4	Connecting control devices .....	26
7.4.1	RS-232C communication .....	27
7.4.2	LAN communication .....	28
7.4.3	Contact closure .....	29
7.5	Connecting power cord .....	29
8	Operation .....	30
8.1	Powering on .....	31
8.2	Front panel operations .....	32
8.2.1	Selecting menu .....	32
8.2.2	Selecting input channels .....	33
8.2.3	Selecting video and audio separately .....	33
8.2.4	Enabling window combination .....	34
8.2.5	Registering/Executing control commands .....	37
8.2.6	Front panel security lockout .....	37
8.2.7	Initialization .....	39
8.3	WEB browser operations .....	40
8.3.1	Starting WEB menu .....	40
8.3.2	Form controls .....	41
8.3.3	Normal/Advanced menu .....	42
8.3.4	Editing crosspoint name .....	42
8.3.5	Saving bitmap .....	43
8.3.6	Automatic reload .....	45
8.3.7	Saving/Restoring settings .....	46
8.3.8	Initialization .....	47
9	Configuration and Control .....	48
9.1	Menu .....	48
9.2	Input signal automatic detection .....	52
9.3	Output position, size, and masking .....	54

9.3.1 Output resolution .....	54
9.3.2 Aspect ratio for sink device .....	55
9.3.3 Image position .....	56
9.3.4 Image size .....	57
9.3.5 Cropping .....	58
9.3.6 Background color .....	59
9.3.7 Test pattern .....	60
9.3.8 Image Initialization .....	61
9.4 Output .....	62
9.4.1 Presence of output signal for when signal is input .....	62
9.4.2 Presence of output signal for when no signal is input .....	62
9.4.3 HDCP output .....	63
9.4.4 HDCP retries .....	63
9.4.5 Connection Reset .....	64
9.4.6 Output equalizer .....	64
9.4.7 Output format .....	65
9.4.8 HDBaseT output long reach mode .....	65
9.4.9 Deep Color output .....	65
9.4.10 Window transition effect .....	66
9.4.11 Window transition speed .....	66
9.4.12 Sink device EDID check .....	67
9.4.13 CEC connection .....	67
9.5 Input position, size, and cropping .....	68
9.5.1 Aspect ratio .....	68
9.5.2 Aspect ratio control .....	69
9.5.3 Overscan .....	69
9.5.4 Image position .....	70
9.5.5 Image size .....	70
9.5.6 Cropping .....	71
9.5.7 Image initialization .....	72
9.6 Input .....	73
9.6.1 DVI input connector signal .....	73
9.6.2 No-signal input monitoring .....	73
9.6.3 HDCP input .....	74
9.6.4 Input equalizer .....	75
9.6.5 Analog input signal parameters .....	75
9.6.6 Automatic detection of video input interruption .....	76
9.6.7 Fixing settings for each input signal .....	77
9.7 Input timing .....	78
9.7.1 Automatic measurement .....	80
9.7.2 The total number of horizontal pixels .....	83
9.7.3 Horizontal start position .....	83
9.7.4 Horizontal active area .....	84
9.7.5 Vertical start position .....	84
9.7.6 Vertical active area .....	84
9.7.7 Automatic measurement of start position .....	85
9.7.8 Automatic setting of input timing .....	86
9.7.9 Initializing digital input timing .....	86
9.7.10 Recalling analog input timing .....	87
9.7.11 Saving analog input timing .....	87

9.7.12 Tracking .....	87
9.8 Automatic input channel switching .....	88
9.8.1 Signal ON priority .....	88
9.8.2 Signal OFF priority .....	89
9.8.3 Ignoring duration after automatic switching .....	89
9.8.4 Channel switching mode of automatic switching .....	90
9.9 Picture controls .....	91
9.9.1 Output brightness .....	91
9.9.2 Output contrast .....	91
9.9.3 Output gamma .....	91
9.9.4 Output video correction initialization .....	92
9.9.5 Input sharpness .....	92
9.9.6 Input brightness .....	92
9.9.7 Input contrast .....	92
9.9.8 Input hue .....	93
9.9.9 Input saturation .....	93
9.9.10 Input black level .....	93
9.9.11 Input video correction initialization .....	93
9.10 Output audio .....	94
9.10.1 Output audio .....	95
9.10.2 Output audio level .....	95
9.10.3 Audio mute .....	95
9.10.4 Output Lip Sync .....	96
9.10.5 Sampling frequency .....	96
9.10.6 Multi-channel audio output .....	97
9.10.7 Multi-channel audio output priority .....	97
9.10.8 Test tone .....	98
9.11 Input audio .....	99
9.11.1 Input audio .....	99
9.11.2 Input audio level offset .....	99
9.11.3 Input Lip Sync .....	99
9.11.4 Stable input audio wait .....	99
9.12 EDID .....	100
9.12.1 EDID selection .....	100
9.12.2 Input resolution .....	101
9.12.3 Copying EDID .....	102
9.12.4 HDMI/DVI .....	103
9.12.5 Frame rate .....	103
9.12.6 Deep Color input .....	104
9.12.7 LPCM audio .....	104
9.12.8 AAC audio .....	105
9.12.9 Dolby Digital audio .....	105
9.12.10 Dolby Digital Plus audio .....	106
9.12.11 Dolby TrueHD audio .....	106
9.12.12 DTS audio .....	107
9.12.13 DTS-HD audio .....	107
9.12.14 Speaker configuration .....	108
9.13 RS-232C .....	110
9.13.1 RS-232C communication .....	110
9.13.2 RS-232C operation mode .....	110

9.14 LAN .....	111
9.14.1 IP address .....	111
9.14.2 Subnet mask.....	111
9.14.3 Gateway address .....	111
9.14.4 MAC address.....	112
9.14.5 TCP port number.....	112
9.14.6 LAN operation mode .....	113
9.14.7 HDBaseT LAN .....	113
9.15 Control commands.....	114
9.15.1 Registering/Editing control command .....	116
9.15.2 Registering/Editing reply command .....	121
9.15.3 Command link.....	124
9.15.4 Command execution .....	126
9.15.5 Initializing registered command and link .....	126
9.15.6 Invalid duration at control command execution .....	127
9.15.7 Illuminating function buttons.....	127
9.15.8 Function button blinking duration .....	128
9.15.9 Assigning function .....	128
9.16 Preset memory.....	129
9.16.1 Recalling crosspoint .....	129
9.16.2 Saving crosspoint .....	129
9.16.3 Editing crosspoint.....	130
9.16.4 Recalling preset memory.....	131
9.16.5 Saving preset memory .....	131
9.16.6 Layout pattern .....	133
9.16.7 Copying output setting.....	133
9.16.8 Start-up settings .....	134
9.17 Bitmap .....	135
9.17.1 Bitmap output .....	136
9.17.2 Background color .....	136
9.17.3 Aspect ratio.....	137
9.17.4 Image position .....	138
9.17.5 Assigning input channel .....	139
9.17.6 Start-up bitmap output.....	139
9.17.7 Dividing memory area .....	140
9.17.8 Output image capture .....	143
9.18 Overlay bitmap.....	144
9.18.1 Overlay bitmap output .....	145
9.18.2 Image position .....	145
9.18.3 Transparency.....	146
9.18.4 Blending.....	146
9.19 Start-up setting.....	147
9.19.1 Power state.....	147
9.19.2 Sending control command automatically .....	147
9.19.3 Front panel security lockout .....	147
9.20 Configuring MSD-S .....	148
9.20.1 PinP window setting .....	148
9.20.2 Channel switching mode .....	148
9.20.3 Grouping front panel security lockout.....	148
9.20.4 Beep .....	149

9.20.5 Alarm .....	149
9.20.6 Displaying advanced menu .....	149
9.20.7 Power saving .....	150
9.20.8 Button press dwelling time .....	150
9.20.9 Top page .....	150
9.21 Status .....	151
9.21.1 Sink device status .....	151
9.21.2 Viewing sink device EDID .....	153
9.21.3 Input signal status .....	154
9.21.4 System status .....	156
9.21.5 Fan status .....	156
9.21.6 Device information .....	156
9.21.7 HDBaseT status .....	157
9.22 Factory default list .....	158
10 Specification .....	164
10.1 DVI input connector .....	164
10.2 Product specification .....	165
10.2.1 MSD-S51 .....	165
10.2.2 MSD-S52 .....	167
10.2.3 MSD-S71 .....	169
10.2.4 MSD-S72 .....	171
11 Troubleshooting .....	173

## 1 Included items

Ensure that all items illustrated below are included in the package.  
If any items are missing or damaged, please contact IDK.

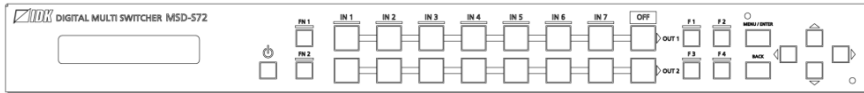

One (1) main unit (Example: MSD-S72)

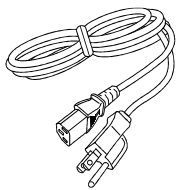

One (1) power cord, 6 ft. (1.8 m)

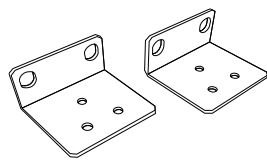

Two (2) rack mounting brackets



Six (6) M4 screws

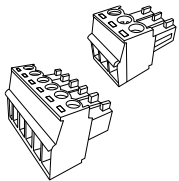

3-pin captive screw connectors:  
Five (5) for MSD-S51/S71  
Six (6) for MSD-S52/S72  
One (1) 6-pin captive screw  
connector

[Fig. 1.1] Included items

## 2 About MSD-S

The MSD-S series is high performance, digital presentation switcher with a built-in scan converter.

The following input signal formats are supported: HDMI, DVI, RGB, and YPbPr. Input video signals are output to HDBaseT and HDMI signals simultaneously at up to QWXGA or 1080p. Two selected input video signals can be displayed on a single screen in picture-in-picture or side-by-side layout. The overlay bitmap function is also supported.

For audio input, both digital and analog audio are supported. The Lip Sync function adjusts the gap between video and audio.

The MSD-S can be configured remotely from RS-232C and LAN while external devices can be controlled via RS-232C, LAN, CEC, or contact closure by registering control commands. The waiting function helps you to send external commands after cooling time passes as power supply control of projectors or the like. External control commands can be executed from front buttons, RS-232C, or LAN; they can also be executed when input selection buttons or power supply button is operated.

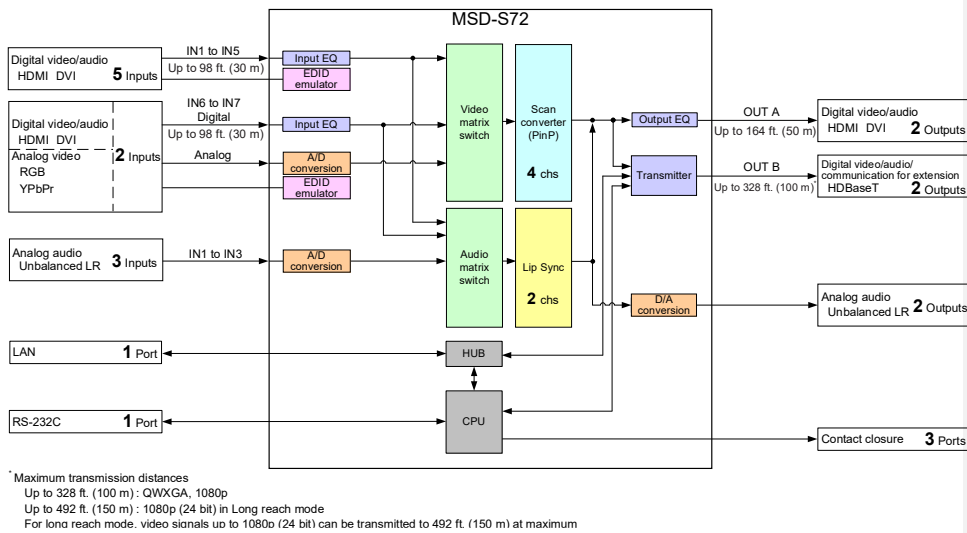

[Fig. 2.1] MSD-S72 diagram

## 3 Features

---

### ■ Video

- Up to 1080p/QWXGA (Reduced Blanking)
- Automatic signal equalization
- Motion adaptive interlaced/progressive conversion
- Scan conversion
- Aspect ratio control
- Seamless switching with one black frame
- Analog/Digital conversion
- Each video output OFF
- Anti-snow
- Two video combinations: PinP and side-by-side
- Overlay bitmap
- Up to 492 ft. (150 m) over Cat6 cable in Long reach mode<sup>\*1</sup>

### ■ Control output

- Control command output (e.g. controlling projectors)
- PLink
- CEC (Control sink device power)
- Contact closure

### ■ Others

- EDID emulation
- WEB browser control
- Automatic input channel switching
- Audio breakaway for independent audio and video switching
- Crosspoint memory
- Preset memory
- Last memory
- Connection Reset
- Button security lockout
- System check
- HDBaseT: RS-232C, LAN and CEC are supported
- HDBaseT status display
- Standby switch

### ■ Audio

- Embedding/De-embedding
- Volume adjustment (Input/Output)
- Lip Sync
- Audio Downmix
- Sampling rate conversion

### ■ Control input

- RS-232C
- LAN

<sup>\*1</sup> For long reach mode, video signals up to 1080p (24 bit) can be transmitted to 492 ft. (150 m) at maximum if using with IDK's HDBaseT products supporting 328 ft. (100 m) transmission.

## 4 Panels

### 4.1 Front/Side panels

#### ● Front panel

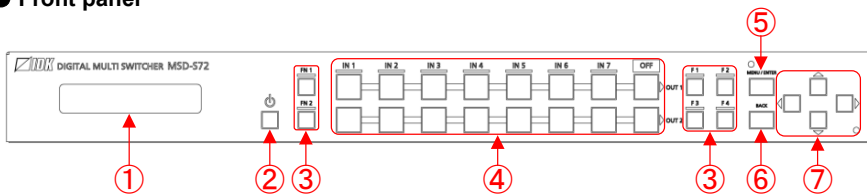

#### ● Side panels

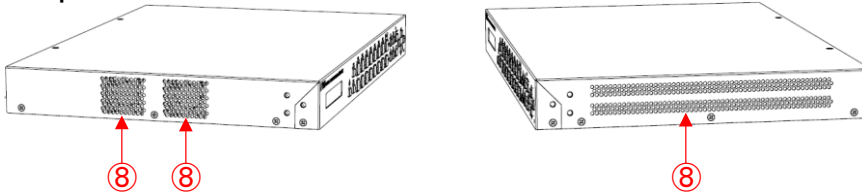

[Fig. 4.1] Front/side panel drawings (MSD-S72)

[Table 4.1] Front/side panel features

#	Feature	Description
①	Front display	Displays menus and settings.
②	Standby button	Switches the power status (Powered ON/Standby). To switch to standby mode, press and hold this mode for one second. Lights green : Powered on Lights amber : Standby Does not light : Powered off
③	F buttons	Function buttons
	FN buttons	Executes registered control commands.
④	Input selection buttons	Selects an input.
		Lights amber : Video and audio
		Lights green : Video Lights red : Audio
⑤	MENU/ENTER button	Selects menus, edits, controls, and saves settings.
⑥	BACK button	Available only in menu page. Goes back to the previous page.
⑦	Navigation buttons	Navigates menu or changes values of adjustable features.
⑧	Ventilation holes	Prevents internal temperature raise. Do not block ventilation holes.

## 4.2 Rear panel

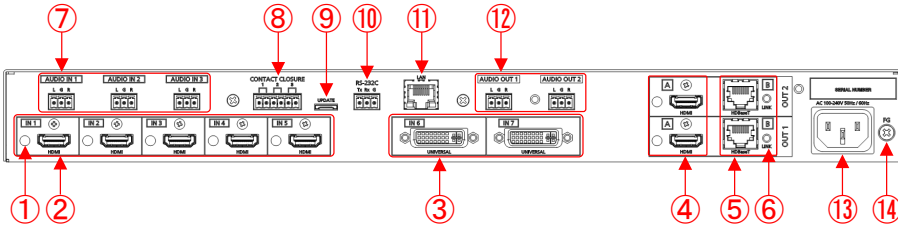

[Fig. 4.2] Rear panel drawing (MSD-S72)

[Table 4.2] Rear panel features

#	Feature	Description
①	HDMI cable fixing holes (Not used)	Not used.
②	HDMI input connectors	Input connectors for HDMI and DVI signals to interface source devices, such as Blu-ray players.
③	Universal input connectors	Input connectors for digital video, digital audio, and analog video signals. Interfaces with DVI-I or DVI-D cable. Each accepts HDMI, DVI, analog RGB, analog YPbPr (SDTV/HDTV)
④	HDMI output connectors	Output connectors for HDMI and DVI signals, interfaces sink devices such as LC monitors and projectors.
⑤	HDBaseT output connectors	Output connector for HDBaseT signal Connects to a remote receiver over a category cable.
⑥	HDBaseT LINK LED	Shows HDBaseT signal connection.
⑦	Analog audio input connector	Input connectors (3-pin captive screw connector) for analog audio signals
⑧	CONTACT CLOSURE connector	For external device control by dry contact closure Connector type is 6-pin captive screw connector.
⑨	Maintenance connector	Factory use only
⑩	RS-232C connector	3-pin captive screw connector for RS-232C serial control
⑪	LAN connector	For external control by communication commands or web browsers
⑫	Analog audio output connector	Analog audio output connector interfaces amplifiers and mixers Connector type is 3-pin captive screw connector.
⑬	Power supply connector	For use with supplied power cable
⑭	Frame ground	Use for bonding chassis to local ground. An M4 screw is used.

## 5 System Configuration Example

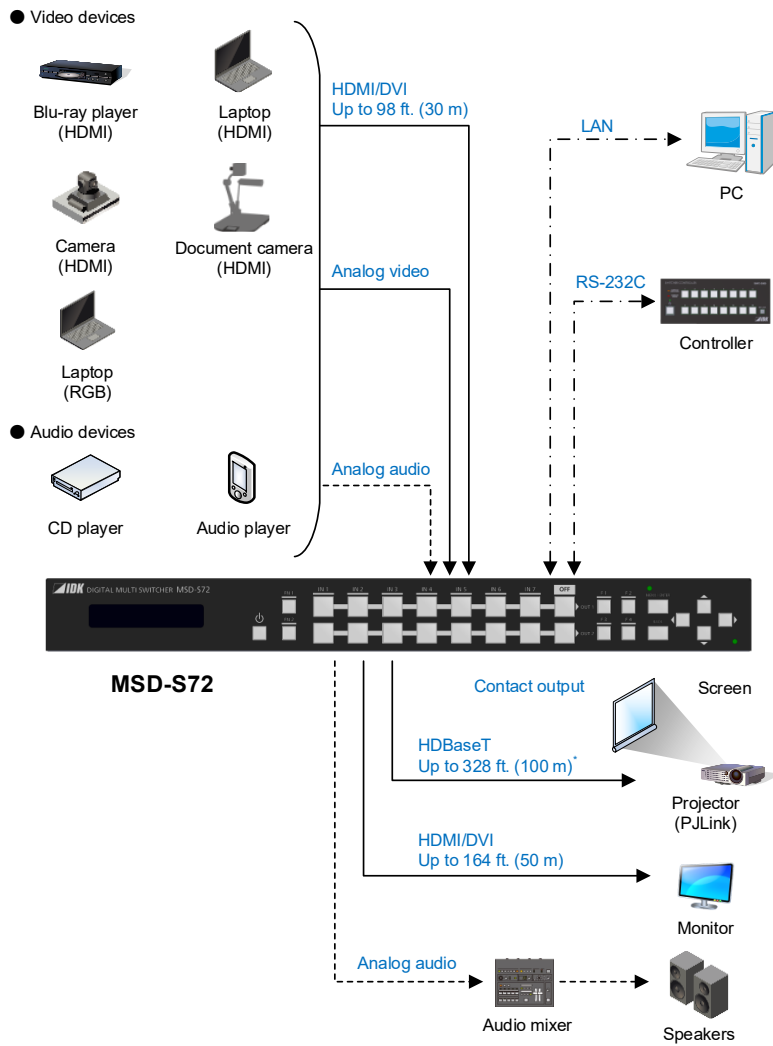

\* Maximum transmission distances

Up to 328 ft. (100 m) : QWXGA, 1080p

Up to 492 ft. (150 m) : 1080p (24 bit) in Long reach mode

For long reach mode, video signals up to 1080p (24 bit) can be transmitted to 492 ft. (150 m) at maximum if using with IDK's HDBaseT products supporting 328 ft. (100 m) transmission.

[Fig. 5.1] System configuration example

## 6 Installation

---

### 6.1 Precautions

---

When installing the MSD-S, observe the following precautions; otherwise, the internal temperature increases and it may affect the product lifetime and operation.

- Do not stack or place one MSD-S directly on top of another MSD-S.
- Do not block vent holes.
- To provide adequate ventilation, maintain sufficient clearances around the MSD-S (1.2 in. (30 mm) or more).
- Consider installing the MSD-S in an environment compatible with the maximum temperature indicated in the specification sheet 32°F to 104°F (0°C to +40°C).

### 6.2 Rack mounting brackets

---

Attach the rack mounting brackets to the MSD-S chassis using the supplied M4 screws. The standard screw tightening torque is 1.47 N·m (about 15.0 kgf·cm).

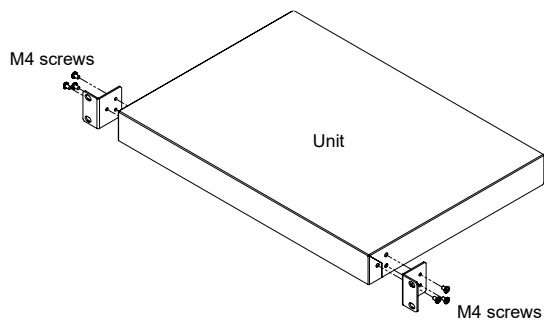

[Fig. 6.1] Attaching rack mounting brackets

## 7 Connection Details

### 7.1 Precautions

When connecting the MSD-S to external devices, observe the following precautions.

- Read manuals for the external devices.
- Before connecting cables to the MSD-S or an external device, dissipate static electricity by touching grounded metal such as equipment racks before handling signal cables. Failure to observe this precaution may result in ESD (electrostatic discharge) damage.
- Power all units off before connecting cables.
- Be sure to fully seat all plugs and connections and dress cables to reduce stress on connectors.

### 7.2 Connecting video devices

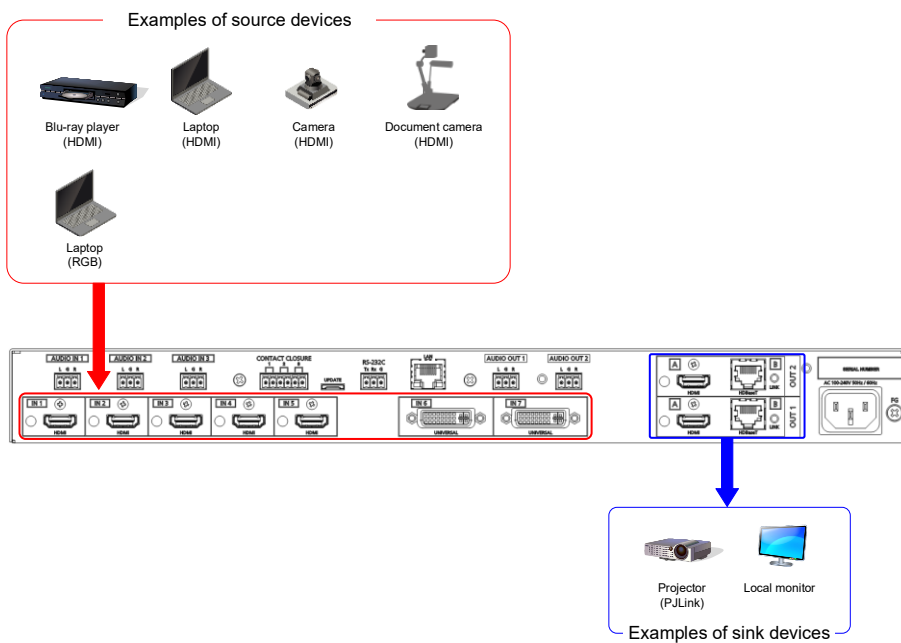

[Fig. 7.1] Connecting video devices

## 7.2.1 Cable Lacing Bracket

Use the cable lacing bracket to secure a standard HDMI cable as shown.

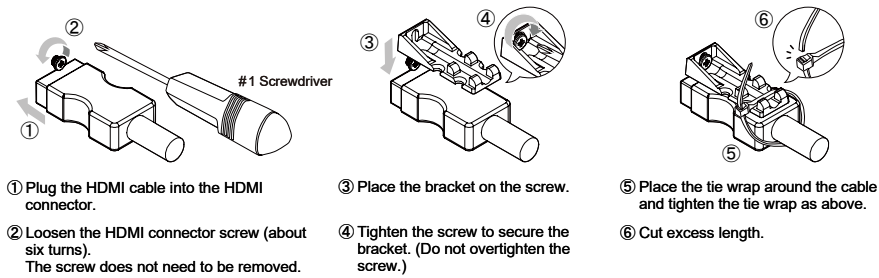

[Fig. 7.2] Cable Lacing Bracket (FB-01 For IDK products only)

## 7.2.2 HDBaseT output connector

HDBaseT output connector supports long reach mode.

With long reach mode, video signals up to 1080p (24 bit) can be transmitted to 492 ft. (150 m) at maximum if using with IDK's HDBaseT products supporting 328 ft. (100 m) transmission.

Enable the HDBaseT Long reach mode from following menus:

【See: 9.3.1 Output resolution】

【See: 9.4.8 HDBaseT output long reach mode】

【See: 9.4.9 Deep Color output】

### 7.2.3 Category cable

To ensure the best performance with category cables, select a high quality category cable type, ensuring that proper pinning and pairing requirements are observed.

- Cat5e UTP/STP and Cat6 UTP/STP can be used, but we recommend CAT.5E HDC cable\* for optimal performance.
- If using STP cables, connect the FG connector to a local electrical ground bonding point. Without bonding FG to ground, the shielding feature may not effectively eliminate interference. If using UTP cables, it is still recommended that the FG connector be used.
- The STP cables are less affected by interference or external noise than UTP cables.
- Connectors for long-haul transmission are the same as that of eight-core modular connector used for Ethernet, but the transmission system is not the same so that it cannot be connected to Ethernet.
- The maximum transmission distance of a category cables is the shorter distance of the maximum transmission distances of transmitter/receiver/sink device connected to the MSD-S.
- Pin assignments: T568A or T568B straight
- Do not pull the cable using excessive force.
- Do not bend the cable at a sharp angle. Keep the bend radius four times of the cable diameter or larger.
- Do not clamp or tie the cable tightly; leave some space allowing the cable to move slightly.
- If you use multiple category cables, keep a distance between the cables or not to place the cables closely in parallel.
- Keep the category cable running as straight as possible. Looping or coiling the cable, causes it to be more easily affected by noise; especially when using longer cable run lengths.
- Do not place the cable in an electrically noisy environment, since high-speed impulsive noise may couple into the category cable. Use of a high-output radio transmission device near the MSD-S or remote receivers may interfere with or interrupt video and or audio signals.
- If the total transmission distance from the transmitter to receiver is 328 ft. (100 m) or less, up to two cable interconnection points can be used. Cable joint supporting Cat6A (10GBase-T) are recommended. For high resolution, video transmission distance may be shortened by about 10%.
- The table below shows supported transmission distance for each category.  
If signals are transmitted for a long haul or with noised from other devices, use a broadband cable or cable having high shielding performance.  
Note that specified distances may shorten depending on the conditions within the actual environment.

**[Table 7.1] Transmission distance**

Noise influence	Category		Transmission distance	TMDS clock	Recommended cable
Easily affected	UTP	Cat5e	164 ft. (50 m)	$\leq 225$ MHz	For 164 ft. (50 m) or longer: CAT.5E HDC*, Cat5e STP, and Cat6 UTP/STP cables
		Cat6	328 ft. (100 m)		
Less affected	STP	Cat5e* Cat6	492 ft. (150 m)	Long reach mode $\leq 148$ MHz (1080p (24 bit) or less)	CAT.5E HDC, Cat5e STP, and Cat6 STP cables

\* The CAT.5E HDC cable is a double-shielded category cable optimized for video signal transmission. The double-shielded structure protects the video signal from external interference. It supports 500 MHz bandwidth at distances up to 328 ft. (100 m).

## 7.2.4 DVI-I input connector

---

Female DVI-I (29-pin) connectors are used for DVI inputs.

【See: 10.1 DVI input connector】

【See: 9.6.1 DVI input connector signal】

【See: 9.6.5 Analog input signal parameters】

**[Table 7.2] Supported cables**

Input signal type	Supported cable
DVI signal	Use DVI-I or DVI-D cable. *Only signal-link is supported.
HDMI signal	Use HDMI-DVI conversion cable.
Analog RGB signal	Use conversion cable which has male DVI-I and female high-density D-sub (15-pin) conversion cable.
Analog YPbPr signal	Use conversion cables as needed for each signal.

## 7.3 Connecting audio device

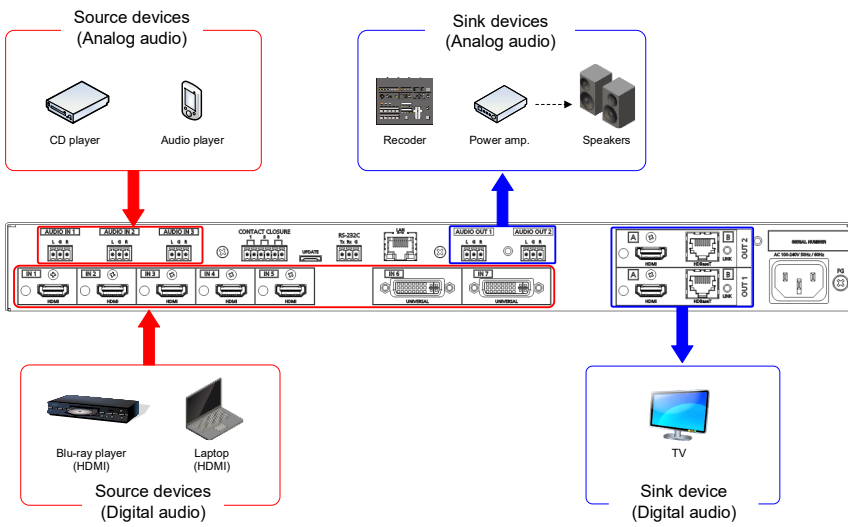

[Fig. 7.3] Connecting to audio devices

### 7.3.1 Audio

Connect the supplied 3-pin captive screw connector to the MSD-S.

The MSD-S supports unbalanced signal.

28 AWG to 16 AWG conductor gauge and a strip length of 0.28 in. (7 mm) are recommended.

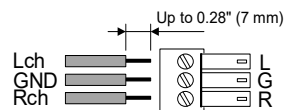

[Fig. 7.4] Connecting audio

## 7.4 Connecting control devices

The MSD-S can control external devices that are connected to HDBaseT output connectors via RS-232C or LAN.

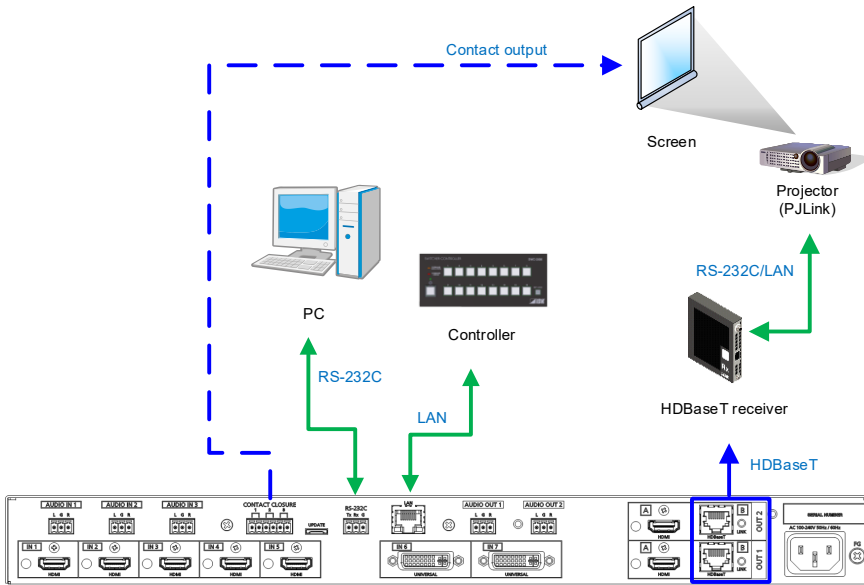

[Fig. 7.5] Application example for control devices

### 7.4.1 RS-232C communication

The RS-232C connector and HDBaseT output connector can communicate with control devices (communication commands) and external devices (control commands) over RS-232C communication. You can select TRANCEIVER mode or RECEIVER mode for each connector in “9.13.2 RS-232C operation mode”.

[See: 9.13.1 RS-232C communication]  
 [See: 9.13.2 RS-232C operation mode]

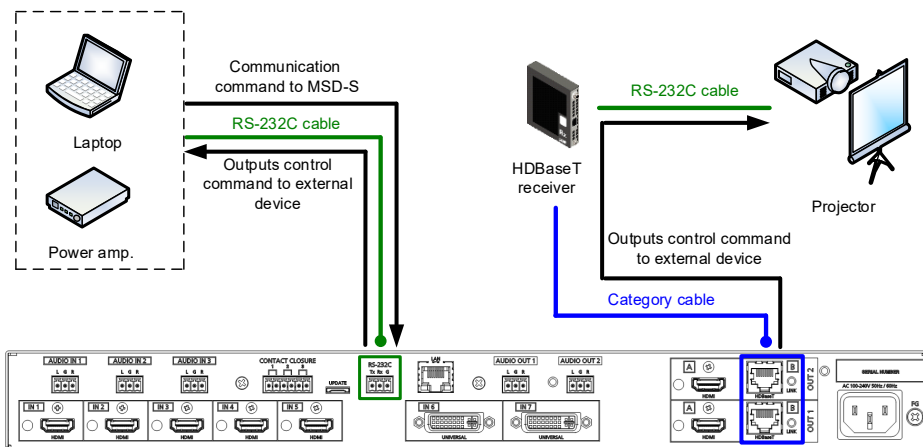

[Fig. 7.6] Example of RS-232C communication

#### ■ Connecting RS-232C cable

Insert and secure the wires from the RS-232C cable into the supplied 3-pin captive screw connector, and then insert the captive screw connector into the mating connector on the MSD-S.

28 AWG to 16 AWG conductor gauge is recommended.

The recommended wire strip length is 0.28 in. (7 mm).

Short RTS/CTS and DTR/DSR as needed.

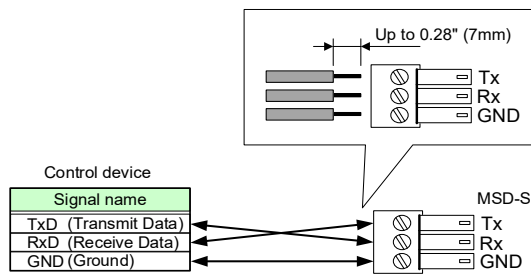

[Fig. 7.7] Connecting RS-232C cable to 3-pin captive screw connector

### 7.4.2 LAN communication

The LAN and HDBaseT output connectors are connected via an internal switching hub and enable the following controls:

- Control command input to the MSD-S from devices connected to the MSD-S's LAN connectors
- Control command output to devices connected to the MSD-S's HDBaseT output connectors from the MSD-S
- Control command to devices connected to the MSD-S's HDBaseT output connectors from devices connected to the MSD-S's LAN connectors
- Control command output to devices connected to the MSD-S's LAN connectors from the MSD-S

The MSD-S has eight connections that can be set individually, and the operation mode will be switched. 【See: 9.14.6 LAN operation mode】

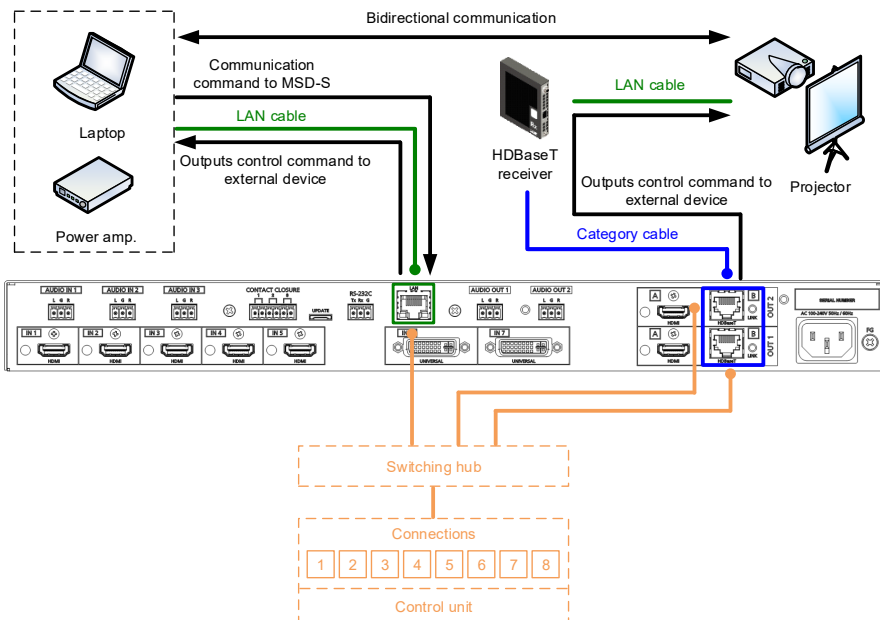

[Fig. 7.8] Example of LAN communication

#### ■ DHCP

The MSD-S does not support automatic acquisition of IP address using DHCP (Dynamic Host Configuration Protocol). If you use the MSD-S in a network with DHCP, use a fixed IP address. If controlling peripheral devices connected over LAN from the MSD-S, use multiple fixed IP addresses.

#### ■ LAN loop problem

The MSD-S includes switching hub function. If the MSD-S communicates with a product having a switching hub over LAN, the network may be down due to loop problem. In case the loop problem occurs, set "9.14.7 HDBaseT LAN" to "OFF".

### 7.4.3 Contact closure

The MSD-S has a total of three independently controlled contact closure channels for external control. Each connector supports three channels. The maximum load is 1 A at 24 VDC per contact.

Connect a cable to the 6-pin captive screw connector, and then insert into the appropriate connector on the MSD-S.

28 AWG to 16 AWG conductor gauge is recommended.

The recommended wire strip length is 0.28 in. (7 mm).

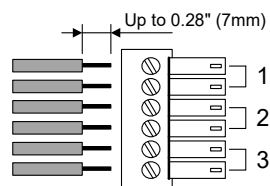

[Fig. 7.9] Connecting cable to 6-pin captive screw connector

### 7.5 Connecting power cord

Connect the supplied power cord.

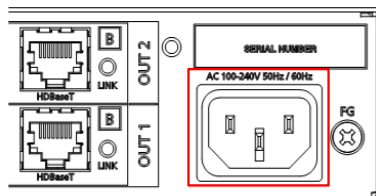

[Fig. 7.10] Connecting power cord

## 8 Operation

The following figures show how video and audio signals are converted and transmitted.

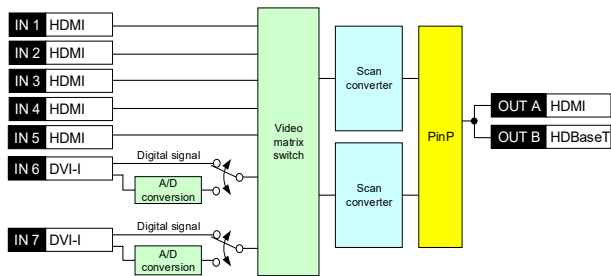

[Fig. 8.1] Video signal transmission (MSD-S71)

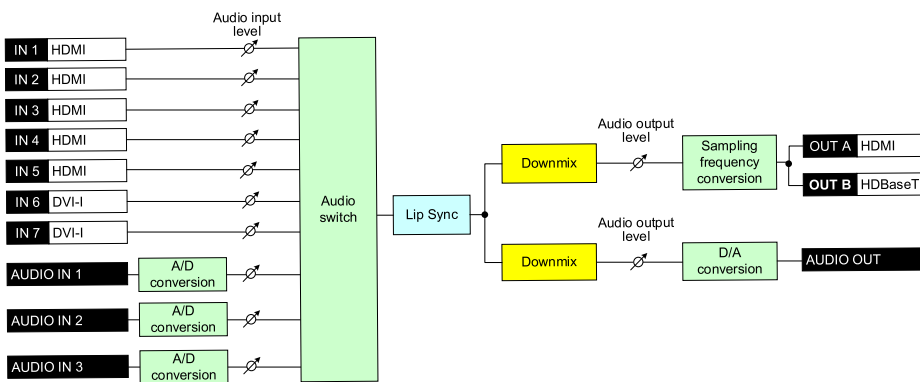

[Fig. 8.2] Audio signal transmission (MSD-S71)

## 8.1 Powering on

---

Connect the MSD-S's AC power cable to power on the MSD-S.

Press and hold the standby button for one second to switch the operation mode to standby. To switch the mode to powered on, press the standby button.

Predictable behavior during power up can be maintained by observing the recommended delay periods listed in the table below. It takes up to 50 seconds depending on the bitmap size.

【See: 9.17.6 Start-up bitmap output】

**[Table 8.1] Power up period**

Operation	Delay period
Receiving RS-232C communication	9 seconds
Receiving LAN communication	17 seconds or longer
Receiving front panel operation	10 seconds or longer
Receiving WEB browser operation	17 seconds or longer

The standby button can be locked.

【See: 8.2.6 Front panel security lockout】

## 8.2 Front panel operations

### 8.2.1 Selecting menu

#### To select a menu:

1. Press the "MENU/ENTER" button.
2. Select the desired menu using "arrow" buttons.
3. Press the "MENU/ENTER" button again to proceed to the following hierarchy.

For some menus, if the LED blinks. You need to press the "MENU/ENTER" button to apply settings.

Illuminated buttons can be selected.

- "MENU/ENTER" button : Displays menu on the front display.
- "Arrow" buttons (▲ · ▼ · ◀, and ▶) : Navigates menu.
- "BACK" button : Returns to the previous hierarchy.

To avoid losing settings, do not interrupt power to the MSD-S while "NOW SAVING" is displayed; otherwise, the setting information may be lost.

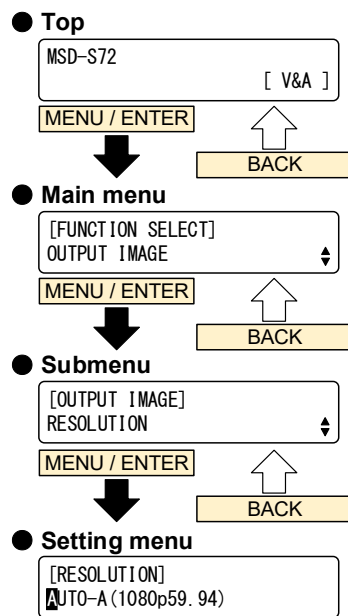

[Fig. 8.3] Selecting menu

### 8.2.2 Selecting input channels

Press the desired "input channel selection" button to output the video and audio you want to output.

For MSD-S52/S72, input channels that are output to OUT1 and OUT2 can be selected. The button lights amber when selected.

Example: MSD-S51



Example: MSD-S72

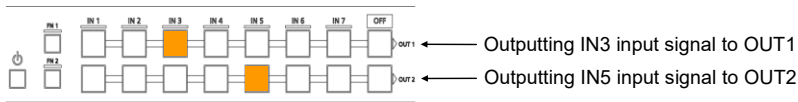

[Fig. 8.4] Selecting input channel

### 8.2.3 Selecting video and audio separately

Audio breakaway enables the audio to be separated from the video.

To enable audio breakaway:

1. Set "9.20.2 Channel switching mode" to "AUDIO".
2. Press the desired "input channel" button for audio. The selected "input channel" lights red.

The buttons light different colors to indicate where video and audio ties are/not the same:

- Amber : Audio is not broken away; video and audio are tied.
- Green (for video) and Red (for audio) : Audio is broken away.

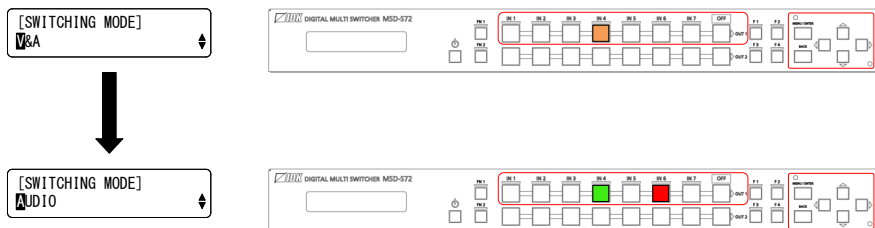

[Fig. 8.5] Setting audio breakaway (Example: Audio is broken away to IN6)

## 8.2.4 Enabling window combination



[Fig. 8.6] Pattern 2 and Pattern 5

### To set window combination:

1. Select a layout pattern from 6 patterns below using the "PinP" button.

【See: 9.16.6 Layout pattern】

Layout patterns (pattern memories) are saved in the following menus of output side:

- 9.3.3 Image position
- 9.3.4 Image size
- 9.3.5 Cropping

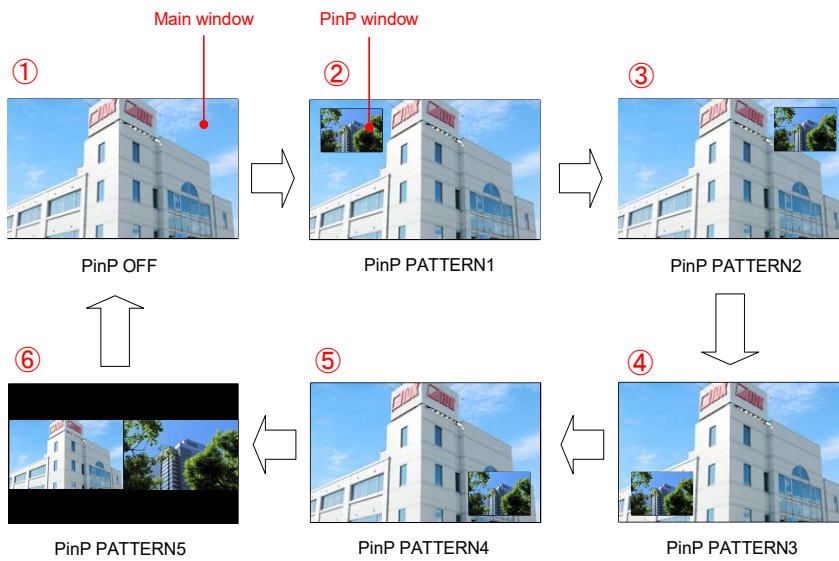

[Fig. 8.7] Selecting layout

2. Select input channel that is output to main window and PinP windows.

First set main or PinP window from SYSTEM SETTING → WINDOW INPUT, and then select the input channel.

【See: 9.20.1 PinP window setting】

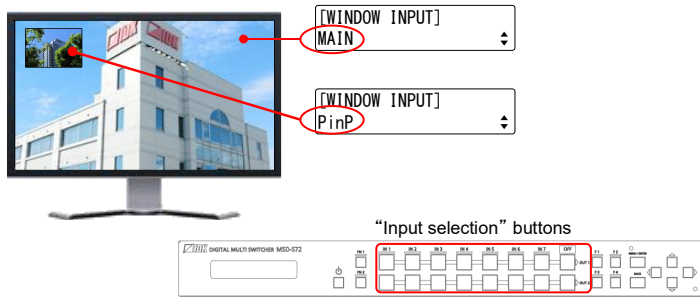

**[Fig. 8.8] Selecting input channel**

3. Adjust window position, size or cropping from menu. Select "IMAGE SIZE" menu and select "MAIN" or "PinP".

"MAIN" : For main window

"PinP" : For PinP window

【See: [Table 8.2] Settable menus for video combination】

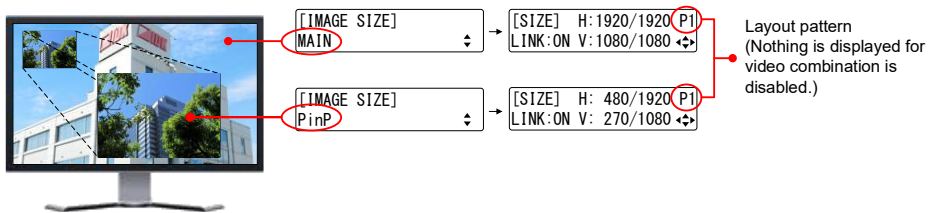

**[Fig. 8.9] Adjusting position and size**

4. Set the following items as needed.

**[Table 8.2] Settable menus for video combination**

Menu	Description	Applied for each pattern separately	Applied to all pattern
Output position, size, and masking	Aspect ratio for sink device	N/A	✓
	Image position	✓	N/A
	Image size	✓	N/A
	Cropping	✓	N/A
	Image Initialization	✓	N/A
Output	Presence of output signal for when no signal is input	N/A	✓
	Window transition effect	N/A	✓
	Window transition speed	N/A	✓
Automatic input channel switching	Signal ON priority	N/A	✓
	Signal OFF priority	N/A	✓
	Ignoring duration after automatic switching	N/A	✓
Picture controls	Output brightness	N/A	✓
	Output contrast	N/A	✓
	Output gamma	N/A	✓
	Output video correction initialization	N/A	✓
Preset memory	Editing crosspoint*	N/A	✓
Bitmap	Bitmap output	N/A	✓
	Aspect ratio	N/A	✓
	Assigning input channel	N/A	✓
	Start-up bitmap output	N/A	✓
Status	Sink device status	N/A	✓

\* PinP enabled/disable, setting PinP channel

### 8.2.5 Registering/Executing control commands

External devices that are connected to the MSD-S can be controlled by registering commands to the following buttons:

- “Standby” button
- “Input selection” buttons
- “Function” buttons
- “FN” buttons

No control commands are registered by default.

【See: 9.15 Control commands】

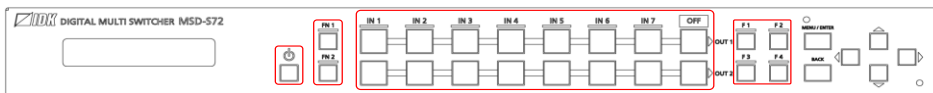

[Fig. 8.10] Buttons for control commands

### 8.2.6 Front panel security lockout

The front panel security lockout limits operation of the MSD-S from the front panel to prevent accidental changes to the controller settings.

【See: 9.20.3 Grouping front panel security lockout】

【See: 9.19.3 Front panel security lockout】

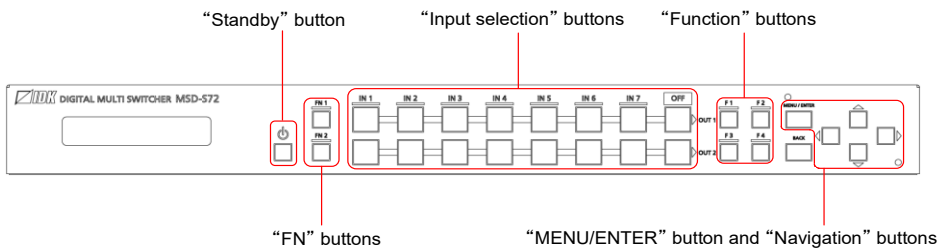

[Fig. 8.11] Buttons/Groups to be locked

**To enable/disable front panel security lockout:**

1. Press and hold the "BACK" button for three buttons.
2. A message is displayed on the front display.
  - Locked : "BUTTON LOCKED !" (For buttons)
  - Unlocked : "BUTTON LOCKED RELEASE !"

To activate F and FN buttons, press and hold them for the set dwelling time.

[See: 9.20.3 Button press dwelling time]

For a cover for menu operation buttons (Navigation, MENU/ENTER, and Back buttons), the front panel has screw holes mentioned below.

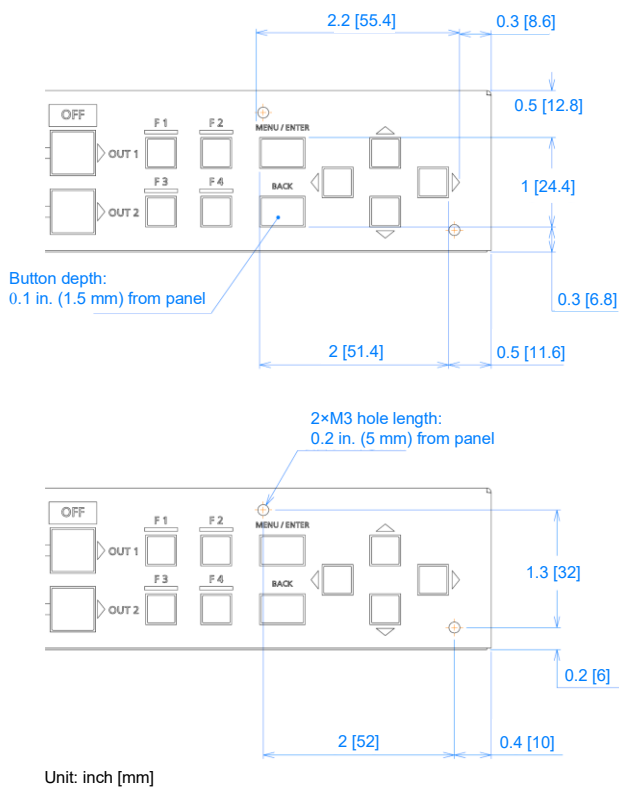

**[Fig. 8.12] Size of cover for menu operation button**

## 8.2.7 Initialization

---

All user configurable settings can be reset to their respective factory default values by powering the MSD-S on while simultaneously depressing the "BACK" button. Press and hold the "BACK" button until you hear a long beep tone.

For factory default, see the list in "**9.22 Factory default list**".

Once initialized, settings of input output channel are set to "OFF", window combination layout pattern is set to "PinP OFF". Note that bitmap memory is not initialized.

When settings are initialized from the WEB browser, they can be initialized without changing LAN settings.

Note that after returning to factory default, the previous setting values cannot be restored.

**[See: 8.3.7 Saving/Restoring settings]**

### 8.3 WEB browser operations

The MSD-S can be controlled, monitored, or configured remotely also via WEB browser.

#### 8.3.1 Starting WEB menu

To control the MSD-S from a WEB browser, enter the IP address that is programmed into the MSD-S in the address bar of the WEB browser. Note that the default IP address is 192.168.1.199. This default address is common among all MSD-S series products.

[See: 9.14 LAN]

[Table 8.3] Example URL

Port number of WEB browser	URL to be entered into address bars
80 (Normal)	http://192.168.1.199
Other than 80 (5000 to 5999)	http://192.168.1.199:5000 (e.g. #5000)

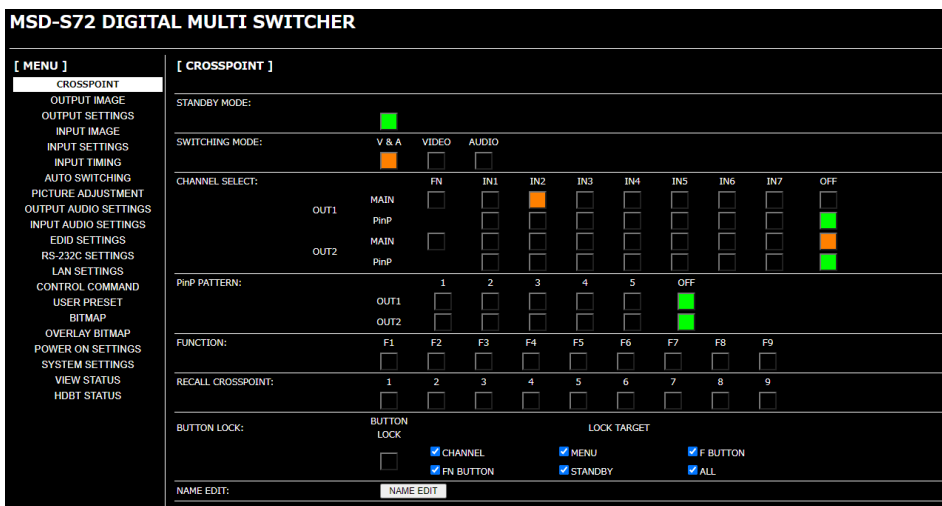

[Fig. 8.13] WEB menu

### 8.3.2 Form controls

To set values from WEB menu:

1. Select the desired item from the menu to display setting items in the submenu.
2. If there is a setting item that can be set for each channel, channel tab will be displayed.
3. Set items in the submenu by referring to the table below.

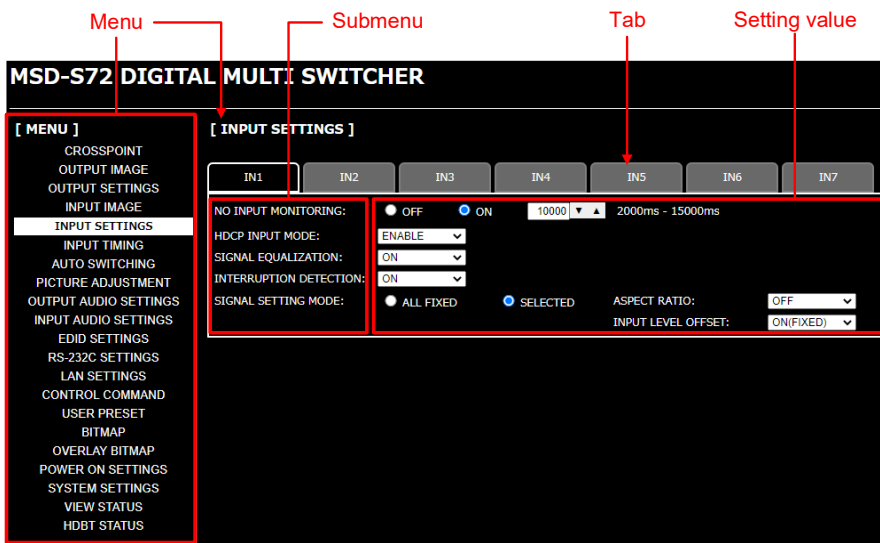

[Fig. 8.14] WEB menu

[Table 8.4] Form controls

Form control	Example	Description
Set/execution button	<input type="button" value="SET"/>	Click the button to execute the desired operation.
Pull down list	<input type="text" value="V&amp;A"/>	Use the down button to select the desired value.
Arrow button	<input type="text" value="10"/>	Use the up/down buttons to set the desired value. You also can enter the value directly.
Check box	<input checked="" type="checkbox"/> MENU	Enables and disables by clicking or unclicking the box.
Radio button	<input type="radio"/> OFF <input checked="" type="radio"/> ON	Select [OFF] or [ON].

### 8.3.3 Normal/Advanced menu

The MSD-S menus consist of normal setting menus and advanced setting menus.

To set advanced setting menus:

1. Select [SYSTEM SETTINGS] from [MENU].
2. Set [ADVANCED MENU] to [ON]. It is set to [OFF] by default.

【See: 9.1 Menu】

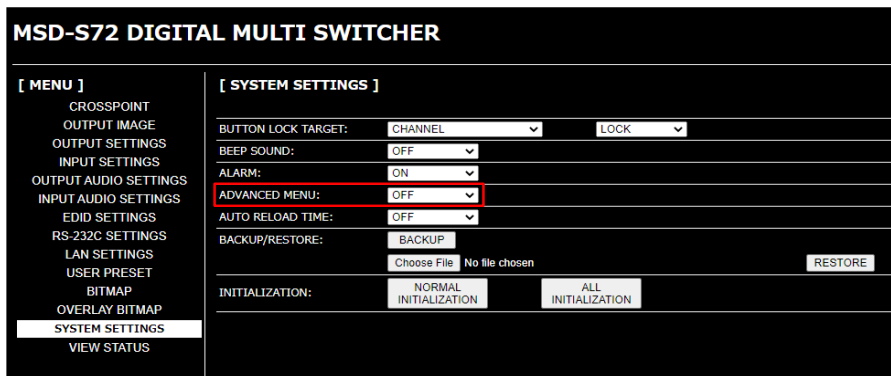

【Fig. 8.15】 Enabling advanced menu

### 8.3.4 Editing crosspoint name

To edit crosspoint name:

1. Click the [NAME EDIT] button from [CROSSPOINT] to open the [NAME EDIT] window.
2. For input output channel names and function button name, enter up to 10 one-byte characters.  
For product models and names, up to 40 one-byte characters.

### 8.3.5 Saving bitmap

To save output video to bitmap memory:

1. Select [SYSTEM SETTINGS] from [MENU].
2. Set [ADVANCED MENU] to [ON].
3. Select [BITMAP] > [MAIN1].
4. Set [FREEZE] to [ON] to freeze the output video temporarily.  
If input channel is switched, the video will be unfrozen.
5. Click [CAPTURE] to start writing video to the bitmap memory.  
Do not perform other WEB operations or power off the MSD-S during the operation.
6. A dialog box showing the end of processing appears. If the registration fails, an error message appears.

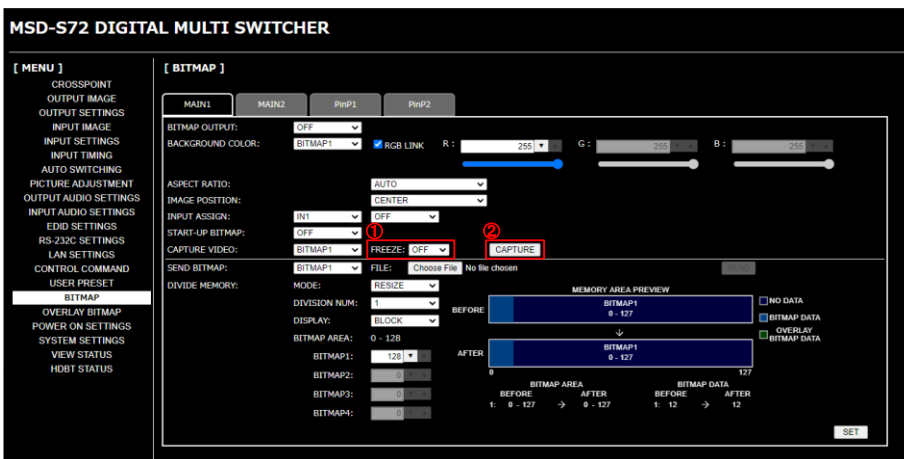

[Fig. 8.16] Saving output video

[Table 8.5] Bitmap registration error

Message	Description
Video Capture is not available because there is no input signal.	The video cannot be captured because no input video appears.
Memory Size Error is happened.	The data cannot be saved because the input video is bigger than reserved memory area.

To save bitmap file to bitmap memory:

1. Select [SYSTEM SETTINGS] from [MENU].
2. Set [ADVANCED MENU] to [ON].
3. Select [BITMAP] > [MAIN1].
4. Select the desired bitmap file from [FILE].
5. Click [SEND] to save the bitmap file to bitmap memory.
6. If the registration fails, an error message appears.

【See: 9.17 Bitmap】

To save overlay bitmap file, perform the same operation from “OVERLAY BITMAP” menu as well.

【See: 9.18 Overlay bitmap】

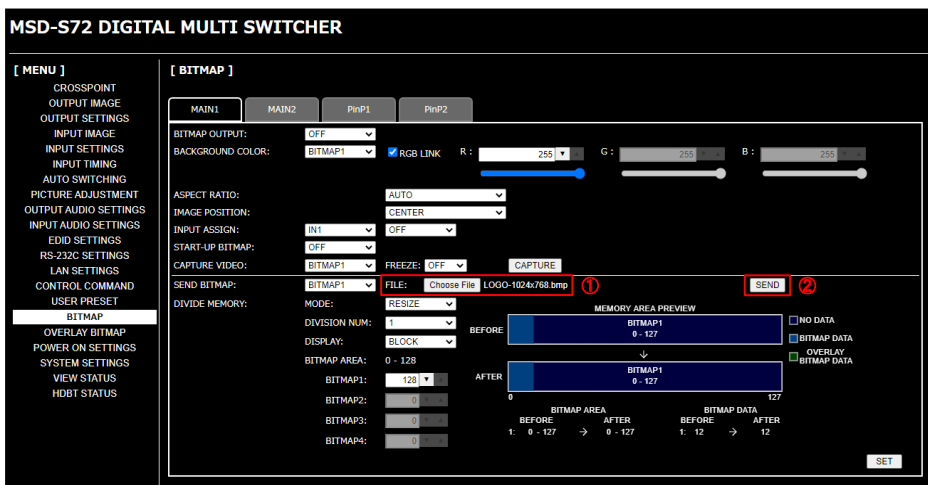

【Fig. 8.17】 Saving bitmap file

【Table 8.6】 Bitmap transfer error message

Message	Description
File Name is invalid.	The specified file name is not correct.
File Format Error is happened.	The MSD-S does not support this file.
File Size exceeds the capacity.	The file exceeds the maximum resolution.
Memory Allocation Error is happened.	The memory for temporarily saving bitmap file could not be reserved. The error may possibly be solved by rebooting the MSD-S, and sending the bitmap file again.

### 8.3.6 Automatic reload

To set automatic reload interval of [CROSSPOINT] and [VIEW STATUS] windows:

1. Select [SYSTEM SETTINGS] from [MENU].
2. Select the desired interval in 1-second increments (1 to 10 seconds) for [AUTO RELOAD TIME].  
If you select [OFF] for [AUTO RELOAD TIME] (default), [CROSSPOINT] and [VIEW STATUS] windows are not updated automatically.

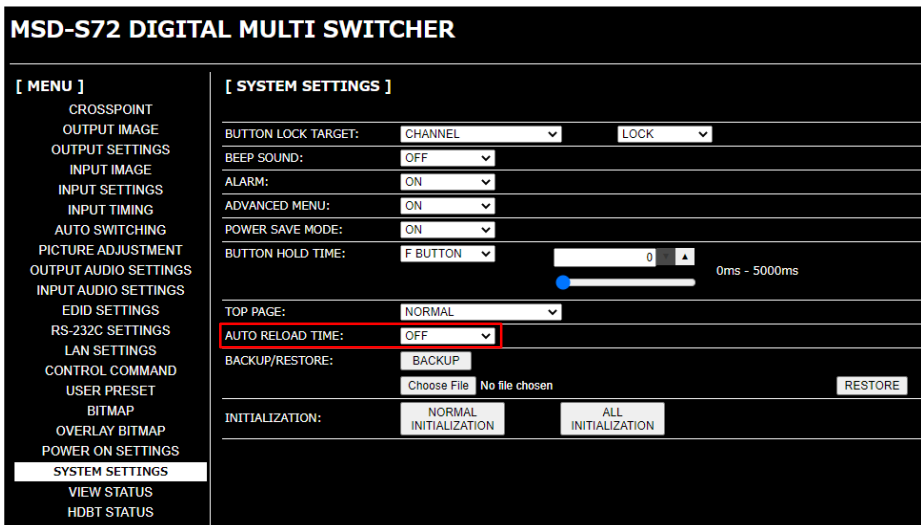

[Fig. 8.18] Setting automatic reload interval

### 8.3.7 Saving/Restoring settings

To save saved settings to a PC as a backup file:

1. Select [SYSTEM SETTINGS] from [MENU].
2. Click the [BACKUP] button of [BACKUP/RESTORE].
3. When the confirmation message appears, click the [OK] button. The backup file named "msd-s72.idm" will be saved to the PC. You can change the file name.

To restore settings from PC:

1. Select [SYSTEM SETTINGS] from [MENU].
2. Select a file from [Choose File].
3. Click the [RESTORE] button of [BACKUP/RESTORE].  
Do not perform other WEB operations or power off the MSD-S during the operation.
4. If the restoration fails, an alert dialog appears during the operation.

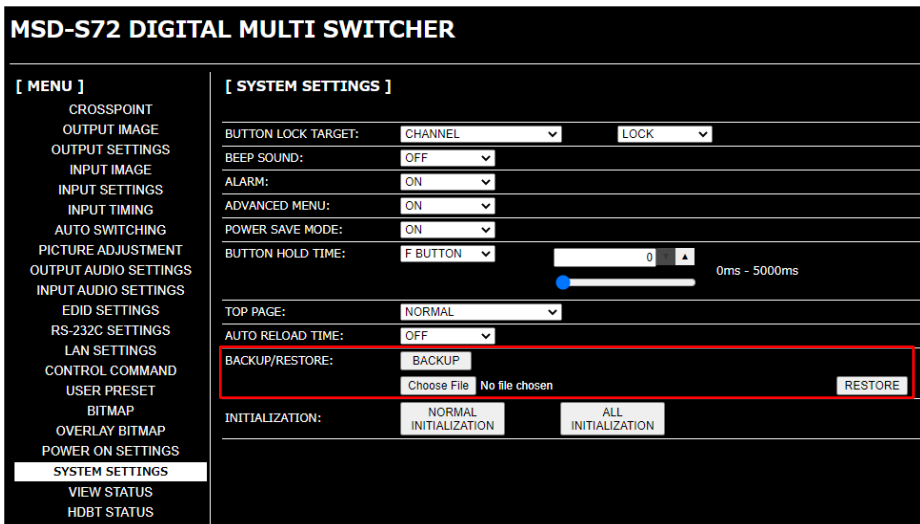

[Fig. 8.19] Saving/Restoring settings

### 8.3.8 Initialization

To reset the MSD-S to factory defaults:

1. Select [SYSTEM SETTINGS] from [MENU].
2. For initializing settings except RS-232C and LAN communication settings: Click the [NORMAL INITIALIZATION] button.  
For initializing all settings including the communication settings: Click the [ALL INITIALIZATION] button.

For factory default, see the list in “9.22 Factory default list”.

Once initialized, settings of input output channel are set to “OFF”, combination layout pattern is set to “PinP OFF”. Note that bitmap memory is not initialized.

Note that after resetting to factory defaults, the previous setting values cannot be restored.

[See: 8.3.7 Saving/Restoring settings]

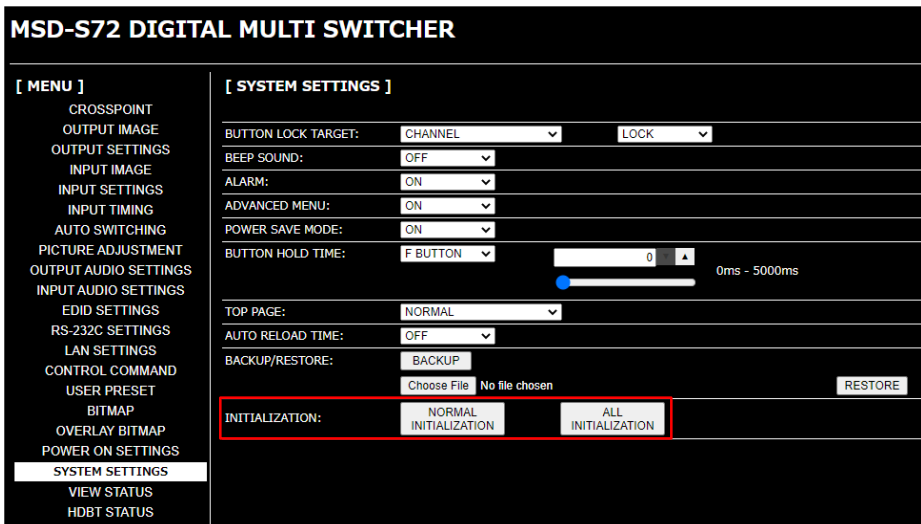

[Fig. 8.20] Initialization

## 9 Configuration and Control

Descriptions in this chapter are based on the MSD-S72.

### 9.1 Menu

The MSD-S menus consist of normal setting menus (○) and advanced setting menus (●).

【See: 9.20.6 Displaying advanced menu】

○OUTPUT IMAGE	Output position, size, and masking	P.54
○RESOLUTION	Output resolution	P.54
●ASPECT RATIO	Aspect ratio for sink device	P.55
○IMAGE POSITION	Image position	P.56
○IMAGE SIZE	Image size	P.57
●IMAGE CROP	Cropping	P.58
○BACKGROUND COLOR	Background color	P.59
○TEST PATTERN	Test pattern	P.60
○IMAGE INITIALIZATION	Image Initialization	P.61
○OUTPUT SETTINGS	Output	P.62
○OUTPUT SIGNAL	Presence of output signal for when signal is input	P.62
●NO SIGNAL IMAGE	Presence of output signal for when no signal is input	P.62
●HDCP OUTPUT MODE	HDCP output	P.63
●HDCP RETRY	HDCP retries	P.63
○CONNECTION RESET	Connection Reset	P.64
○SIGNAL EQUALIZATION	Output equalizer	P.64
●SIGNAL FORMAT	Output format	P.65
○HDBT LONG REACH MODE	HDBaseT output long reach mode	P.65
●Deep Color output	Deep Color output	P.65
●VIDEO SWITCHING EFFECT	Window transition effect	P.66
●SWITCHING EFFECT SPEED	Window transition speed	P.66
●EDID ERR. OUTPUT MODE	Sink device EDID check	P.67
●CEC CONNECTION	CEC connection	P.67
●INPUT IMAGE	Input position, size, and cropping	P.68
●ASPECT RATIO	Aspect ratio	P.68
●ASPECT RATIO CONTROL	Aspect ratio control	P.69
●OVERSCAN	Overscan	P.69
●IMAGE POSITION	Image position	P.70
●IMAGE SIZE	Image size	P.70
●IMAGE CROP	Cropping	P.71
●IMAGE INITIALIZATION	Image initialization	P.72

<b>○INPUT SETTINGS</b>		
○DVI-I: SIGNAL FORMAT	<b>Input</b>	P.73
●NO INPUT MONITORING	DVI input connector signal	P.73
●HDCP INPUT MODE	No-signal input monitoring	P.73
○SIGNAL EQUALIZATION	HDCP input	P.74
●ANALOG INPUT FORMAT	Input equalizer	P.75
●INTERRUPTION DETECTION	Analog input signal parameters	P.75
●SIGNAL SETTING MODE	Automatic detection of video input interruption	P.76
	Fixing settings for each input signal	P.77
<b>●INPUT TIMING</b>	<b>Input timing</b>	P.78
●ANALOG MEASUREMENT	Automatic measurement	P.80
●H TOTAL PIXELS	The total number of horizontal pixels	P.83
●H START POSITION	Horizontal start position	P.83
●H ACTIVE	Horizontal active area	P.84
●V START POSITION	Vertical start position	P.84
●V ACTIVE	Vertical active area	P.84
●START POSITION DETECT.	Automatic measurement of start position	P.85
●UNREGISTERED SIGNAL	Automatic setting of input timing	P.86
●INPUT TIMING INIT.	Initializing digital input timing	P.86
●RECALL ANALOG SETTINGS	Recalling analog input timing	P.87
●STORE ANALOG SETTINGS	Saving analog input timing	P.87
●ANALOG SIGNAL TRACKING	Tracking	P.87
<b>●AUTO SWITCHING</b>	<b>Automatic input channel switching</b>	P.88
●SIGNAL ON PRIORITY	Signal ON priority	P.88
●SIGNAL OFF PRIORITY	Signal OFF priority	P.89
●IGNORING DURATION	Ignoring duration after automatic switching	P.89
●SWITCHING MODE	Channel switching mode of automatic switching	P.90
<b>●PICTURE ADJUSTMENT</b>	<b>Picture controls</b>	P.91
●OUTPUT BRIGHTNESS	Output brightness	P.91
●OUTPUT CONTRAST	Output contrast	P.91
●OUTPUT GAMMA	Output gamma	P.91
●OUTPUT SETTING INIT.	Output video correction initialization	P.92
●INPUT SHARPNESS	Input sharpness	P.92
●INPUT BRIGHTNESS	Input brightness	P.92
●INPUT CONTRAST	Input contrast	P.92
●INPUT HUE	Input hue	P.93
●INPUT SATURATION	Input saturation	P.93
●INPUT BLACK LEVEL	Input black level	P.93
●INPUT SETTING INIT.	Input video correction initialization	P.93
<b>○OUTPUT AUDIO SETTINGS</b>	<b>Output audio</b>	P.94
○OUTPUT SIGNAL	Output audio	P.95
○OUTPUT LEVEL	Output audio level	P.95
○MUTE	Audio mute	P.95
●LIP SYNC	Output Lip Sync	P.96
●SAMPLING FREQUENCY	Sampling frequency	P.96
●DOWNMIX	Multi-channel audio output	P.97
●OUTPUT PRIORITY	Multi-channel audio output priority	P.97
○TEST TONE	Test tone	P.98
<b>○INPUT AUDIO SETTINGS</b>	<b>Input audio</b>	P.99
○INPUT SIGNAL	Input audio	P.99
○INPUT LEVEL OFFSET	Input audio level offset	P.99
●LIP SYNC	Input Lip Sync	P.99
●STABLE WAIT	Stable input audio wait	P.99

<b>EDID SETTINGS</b>	<b>EDID</b>	P.100
○EDID SELECTION	EDID selection	P.100
○RESOLUTION	Input resolution	P.101
○SINK DEVICE EDID COPY	Copying EDID	P.102
●SIGNAL FORMAT	HDMI/DVI	P.103
●FRAME RATE	Frame rate	P.103
●Deep Color input	Deep Color input	
●Linear PCM	LPCM audio	P.104
●AAC	AAC audio	P.105
●Dolby Digital	Dolby Digital audio	P.105
●Dolby Digital Plus	Dolby Digital Plus audio	P.106
●Dolby TrueHD	Dolby TrueHD audio	P.106
●DTS	DTS audio	P.107
●DTS-HD	DTS-HD audio	P.107
●SPEAKER CONFIGURATION	Speaker configuration	P.108
<b>ORS-232C SETTINGS</b>	<b>RS-232C</b>	P.110
○PARAMETERS	RS-232C communication	P.110
●COMMUNICATION MODE	RS-232C operation mode	P.110
<b>LAN SETTINGS</b>	<b>LAN</b>	P.111
○IP ADDRESS	IP address	P.111
○SUBNET MASK	Subnet mask	P.111
○GATEWAY	Gateway address	P.111
○MAC ADDRESS	MAC address	P.112
●PORT NUMBER	TCP port number	P.112
●COMMUNICATION MODE	LAN operation mode	P.113
●HDBT COMMUNICATION	HDBaseT LAN	P.113
● <b>CONTROL COMMAND</b>	<b>Control commands</b>	P.114
●COMMAND REGISTER/EDIT	Registering/Editing control command	P.116
●REPLY REGISTER/EDIT	Registering/Editing reply command	P.121
●COMMAND LINK	Command link	P.124
●EXECUTE CTRL COMMAND	Command execution	P.126
●INITIALIZATION	Initializing registered command and link	P.126
●INVALID DURATION	Invalid duration at control command execution	P.127
●ILLUMINATE FN. BUTTON	Illuminating function buttons	P.127
●BLINKING DURATION	Function button blinking duration	P.128
●FUNCTION ASSIGN	Assigning function	P.128
<b>USER PRESET</b>	<b>Preset memory</b>	P.129
○RECALL CROSSPOINT	Recalling crosspoint	P.129
○STORE CROSSPOINT	Saving crosspoint	P.129
●EDIT CROSSPOINT	Editing crosspoint	P.130
○RECALL PRESET SETTINGS	Recalling preset memory	P.131
○STORE PRESET SETTINGS	Saving preset memory	P.131
○PiP PATTERN	Layout pattern	P.133
○COPY OUTPUT SETTINGS	Copying output setting	P.133
○START-UP	Start-up settings	P.134

<b>OBITMAP</b>	<b>Bitmap</b>	P.135
O BITMAP OUTPUT	Bitmap output	P.136
● BACKGROUND COLOR	Background color	P.136
● ASPECT RATIO	Aspect ratio	P.137
● IMAGE POSITION	Image position	P.138
● INPUT ASSIGN	Assigning input channel	P.139
● START-UP BITMAP	Start-up bitmap output	P.139
● DIVIDE MEMORY	Dividing memory area	P.140
● CAPTURE VIDEO	Output image capture	P.143
<b>O OVERLAY BITMAP</b>	<b>Overlay bitmap</b>	P.144
O OVERLAY BITMAP OUTPUT	Overlay bitmap output	P.145
● IMAGE POSITION	Image position	P.145
● TRANSPARENCY	Transparency	P.146
● BLENDING	Blending	P.146
<b>● POWER ON SETTINGS</b>	<b>Start-up setting</b>	P.147
● START-UP MODE	Power state	P.147
● FUNCTION CMD.EXE.	Sending control command automatically	P.147
● BUTTON LOCK	Front panel security lockout	P.147
<b>O SYSTEM SETTINGS</b>	<b>Configuring MSD-S</b>	P.148
O WINDOW INPUT	PinP window setting	P.148
O SWITCHING MODE	Channel switching mode	P.148
O BUTTON LOCK TARGET	Grouping front panel security lockout	P.148
O BEEP SOUND	Beep	P.149
O ALARM	Alarm	P.149
O ADVANCED MENU	Displaying advanced menu	P.149
● POWER SAVE MODE	Power saving	P.150
● BUTTON HOLD TIME	Button press dwelling time	P.150
● TOP PAGE	Top page	P.150
<b>O VIEW STATUS</b>	<b>Status</b>	P.151
O SINK DEVICE STATUS	Sink device status	P.151
O SINK DEVICE EDID	Viewing sink device EDID	P.153
O INPUT STATUS	Input signal status	P.154
O SYSTEM STATUS	System status	P.156
● FAN STATUS	Fan status	P.156
O VERSION	Device information	P.156
● HDBT STATUS	HDBaseT status	P.157

## 9.2 Input signal automatic detection

The MSD-S continuously monitors its input signals. If a particular signal has previously been connected to the MSD-S's input, the output signal will be presented in the same format as it was during the most recent session.

If an input signal does not match a signal previously presented to the MSD-S, only the input timing settings are automatically negotiated. Other settings are not affected.

The output image size and format settings can be adjusted if required.

【See: 9.6.7 Fixing settings for each input signal】

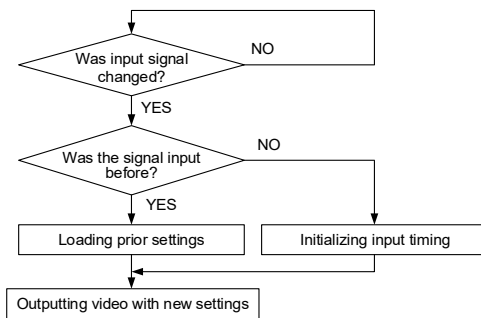

[Fig. 9.1] How input signals are recognized

The MSD-S retains data for up to 50 input devices for each input connector.

The data is used to determine if a signal has been presented to that connector previously by a specific device. Once input data storage exceeds 50 memory locations, the new memory entry will replace the earliest less-frequent entry.

	IN1	IN2	IN3	IN4	IN5	IN6	IN7
1	1080i	1080i	UXGA	UXGA	WXGA	UXGA	UXGA
2	720p	480i	WXGA	VGA	SVGA	XGA	WXGA
3	480i		SXGA+				
4	XGA						
5	SXGA						
6	UXGA						
.....							
49	VGA						
50	1080p						

↑  
If input data storage exceeds 50 memory locations,

The MSD-S retains data for up to 50 devices for each input connector.

[Fig. 9.2] Memory table

The following attributes are saved for each input signal.

**[Table 9.1] Attributes saved for each input signal**

9.5 Input position, size, and cropping	9.5.1 Aspect ratio 9.5.2 Aspect ratio control 9.5.3 Overscan 9.5.4 Image position 9.5.5 Image size 9.5.6 Cropping
9.6 Input	9.6.5 Analog input signal parameters
9.7 Input timing	9.7.2 The total number of horizontal pixels 9.7.3 Horizontal start position 9.7.4 Horizontal active area 9.7.5 Vertical start position 9.7.6 Vertical active area 9.7.7 Automatic measurement of start position 9.7.12 Tracking
9.9 Picture controls	9.9.5 Input sharpness 9.9.6 Input brightness 9.9.7 Input contrast 9.9.8 Input hue 9.9.9 Input saturation 9.9.10 Input black level
9.11 Input audio*	9.11.2 Input audio level offset 9.11.3 Input Lip Sync

\*Audio settings are set automatically only if digital audio input is selected.

## 9.3 Output position, size, and masking

Position, size, and masking attributes can be set for both the input ports and output ports of the MSD-S. Normally, it is preferable to set them for the input ports. If edges are cut off due to an enlarged display area by the sink device or if it is desired to modify the displayed area for all inputs at once, set the desired attributes for the output ports.

【See: 9.5 Input position, size, and cropping】

Video signals are output in the following order:

Background color→Main window→PinP window→Overlay bitmap

The settings for video combination can be changed for each layout pattern.

【See: 8.2.4 Enabling window combination】

【See: 9.17 Bitmap】

【See: 9.18 Overlay bitmap】

### 9.3.1 Output resolution

Menu	Top→OUTPUT IMAGE→RESOLUTION		
Setting for	ALL, OUT1, OUT2		
Setting value			
• AUTO-A [Default]	• 720p 50Hz	• SXGA+	(1400x1050)
• AUTO-B	• 576p 50Hz	• WXGA	(1366x768)
• 1080p 60Hz	• 480p 59.94Hz	• WXGA	(1360x768)
• 1080p 59.94Hz	• QWXGA (2048x1152)	• SXGA	(1280x1024)
• 1080p 50Hz	• WUXGA (1920x1200)	• QuadVGA	(1280x960)
• 1080i 60Hz	• VESAHD (1920x1080)	• WXGA	(1280x800)
• 1080i 59.94Hz	• WSXGA+ (1680x1050)	• WXGA	(1280x768)
• 1080i 50Hz	• UXGA (1600x1200)	• XGA	(1024x768)
• 720p 60Hz	• WXGA++ (1600x900)	• VGA	(640x480)
• 720p 59.94Hz	• WXGA+ (1440x900)		

The optimal resolution will be selected automatically if you set this menu to "AUTO".

480p/576p/720p/1080i/1080p are timing formats relating to the CEA-861 standard.

Other timing formats, such as XGA, WXGA, QWXGA, are compliant with VESA DMT or VESA CVT standard.

WUXGA and QWXGA are output formats that incorporate Reduced Blanking.

\* Video is output at the optimal resolution from EDID of sink device that is connected to the following connectors:

“AUTO-A”: OUT A (HDMI output connector)

“AUTO-B”: OUT B (HDBaseT output connector)

The actual output resolution is displayed in parentheses. In case EDID cannot be obtained from the sink device, the resolution format that was last used is selected. This condition is indicated by an asterisk “\*” to the right side of the format data.

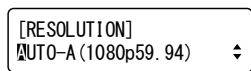

Outputting at optimal resolution

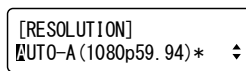

EDID cannot be loaded or optimal resolution cannot be output

### 9.3.2 Aspect ratio for sink device

Menu	Top→OUTPUT IMAGE→ASPECT RATIO			
Setting for	MAIN1, MAIN2, PinP1, PinP2			
Setting value	RESOLUTION* [Default]	4:3	5:4	5:3
	16:9	16:10		

\* If you select “RESOLUTION”, the aspect ratio of the output resolution will be applied. If aspect ratios of the target sink device and the output resolution are different from each other, you can select one of the following aspect ratios for the sink device: “4:3”, “5:4”, “5:3”, “16:9”, and “16:10”.

The aspect ratio is adjusted based on this setting and the aspect ratio of input signal.

For PinP, the aspect ratio is adjusted according to the aspect ratio that is set in this menu.

【See: 9.5.1 Aspect ratio】

【See: 9.5.2 Aspect ratio control】

For PinP, if the set aspect ratio values that are set in this menu and image size are matched, video is output at the correct ratio.

【See: 9.3.4 Image size】

### 9.3.3 Image position

Menu Top→OUTPUT IMAGE→IMAGE POSITION

Setting for MAIN1, MAIN2, PinP1, PinP2  
[PinP: PATTERN 1 to PATTERN 5]

Setting value

Horizontal position : -Horizontal output size to +Horizontal output resolution [by 1 pixel]

Vertical position : -Vertical output size to +Vertical output resolution [by 1 line]

**[Table 9.2] Default image position (at 1080p)**

Pattern	Main (Horizontal/Vertical)	PinP (Horizontal/Vertical)
—	0/0	— (N/A)
P1	0/0	80/45
P2	0/0	1360/45
P3	0/0	80/765
P4	0/0	1360/765
P5	0/270	960/270

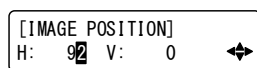

**[Fig. 9.3] Setting image position page**

The image position is based on the upper left quadrant of the window.

Image position range changes depending on the image size.

The image position is set within the range automatically if the set image position is bigger than the set image size.

**[See: 9.3.4 Image size]**

PinP settings can be set for each pattern memory. If PinP is set with PinP disabled, a message, "NOT AVAILABLE NOW", appears.

The settable range varies depending on the settings of output resolution and image size.

If output resolution or image size is changed, image position setting is automatically changed without changing its starting position.

**[See: 9.3.1 Output resolution]**

**[See: 9.3.4 Image size]**

### 9.3.4 Image size

Menu Top→OUTPUT IMAGE→IMAGE SIZE

Setting for MAIN1, MAIN2, PinP1, PinP2  
[PinP: PATTERN 1 to PATTERN 5]

Setting value

Horizontal size : Horizontal output resolution ÷4 to Horizontal output resolution ×4 [by 1 pixel]

Vertical size : Vertical output resolution ÷4 to Vertical output resolution ×4 [by 1 line]

**[Table 9.3] Default image size (at 1080p)**

Pattern	Main (Horizontal/Vertical)	PinP (Horizontal/Vertical)
—	1920/1080	—(N/A)
P1	1920/1080	480/270
P2	1920/1080	480/270
P3	1920/1080	480/270
P4	1920/1080	480/270
P5	960/540	960/540

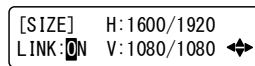

**[Fig. 9.4] Setting image size page**

The video size is scaled (quarte to quadruple) based on the upper left quadrant of the output image position. If you set "LINK" to "ON", only settings of "H" (Horizontal) can be set and "V" (Vertical) is set automatically while retaining the current aspect ratio.

Numbers following "/" show the output resolution.

**[See: 9.3.3 Image position]**

PinP settings can be set for each pattern memory. If PinP is set with PinP disabled, a message, "NOT AVAILABLE NOW", appears.

The settable range varies depending on the settings of output resolution.

If output resolution or image size is changed, image size setting is automatically changed without changing the scale.

**[See: 9.3.1 Output resolution]**

### 9.3.5 Cropping

Menu Top→OUTPUT IMAGE→IMAGE CROP

Setting for MAIN1, MAIN2, PinP1, PinP2  
 [PinP: PATTERN 1 to PATTERN 5]

**Setting value**

- Left side cropping : Horizontal output position (0 or more) to Right side cropping [by 1 pixel]
- Right side cropping : Left side cropping to Horizontal output position + Horizontal output size (Horizontal output resolution or less) [by 1 pixel]
- Top side cropping : Vertical output position (0 or more) to Bottom side cropping [by 1 line]
- Bottom side cropping : Top side cropping to Vertical output position + Vertical output size (Vertical output resolution or less) [by 1 line]

**[Table 9.4] Default cropping value (at 1080p)**

Pattern	Main (Left/Right/Top/Bottom)	PinP (Left/Right/Top/Bottom)
—	0/1920/0/1080	— (N/A)
P1	0/1920/0/1080	80/560/45/315
P2	0/1920/0/1080	1360/1840/45/315
P3	0/1920/0/1080	80/560/765/1035
P4	0/1920/0/1080	1360/1840/765/1035
P5	0/960/270/810	960/1920/270/810

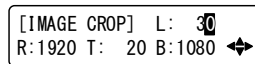

**[Fig. 9.5] Setting image size page**

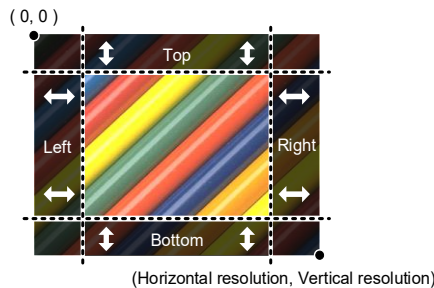

**[Fig. 9.6] Output cropping**

Settable cropping range depends on the following settings:

- 9.3.1 Output resolution
- 9.3.3 Image position
- 9.3.4 Image size

If output resolution, image position, or image size is changed, cropping setting is also changed automatically with the display range kept.

PinP settings can be set for each pattern memory.

If PinP is set with PinP disabled, a message, "NOT AVAILABLE NOW", appears.

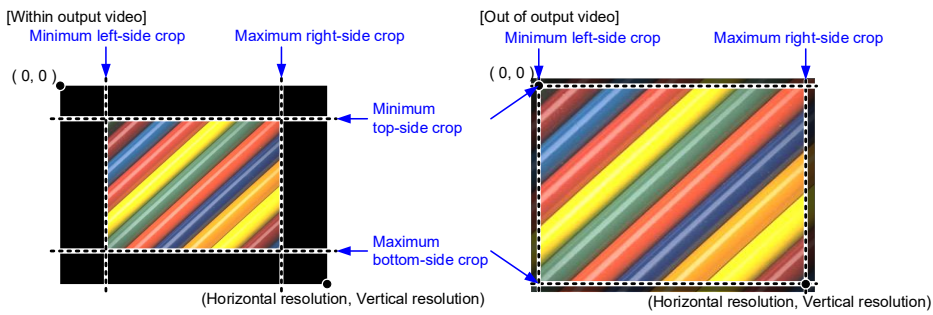

[Fig. 9.7] Output cropping range

### 9.3.6 Background color

Menu	Top→OUTPUT IMAGE→BACKGROUND COLOR
Setting for	OUT1, OUT2
Setting value	R/G/B: 0 to 255 [Default] R/G/B: 0 (Black)

You can set the background color of output video signal.

If you set "LINK" to "ON", only the setting for "R" can be adjusted, and in this mode, "G" and "B" will automatically track the setting of "R".

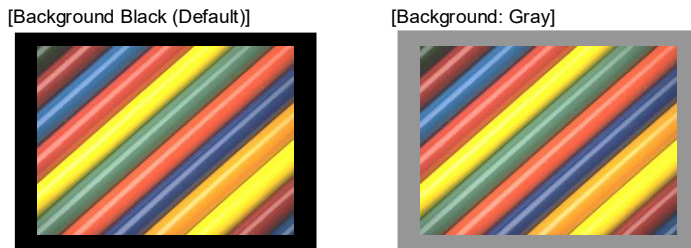

[Fig. 9.8] Background color

### 9.3.7 Test pattern

Menu Top→OUTPUT IMAGE→TEST PATTERN  
 Setting for ALL, OUT1, OUT2  
 Setting value

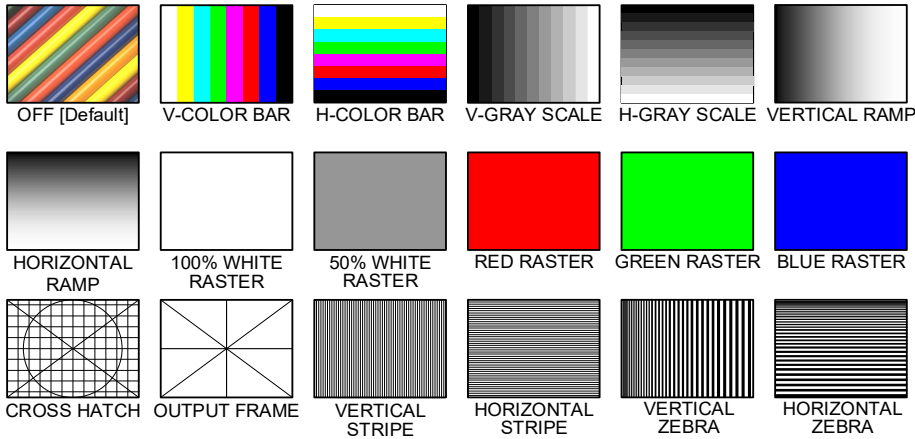

[Fig. 9.9] Test pattern

You can activate the MSD-S's internal test pattern generator and direct its signal to each output connector.

For test patterns other than "OUTPUT FRAME": Video is output on full screen with the resolution format as set in Output resolution and the settings of Image position, Image size, and Cropping will be invalid.

"OUTPUT FRAME": Select this pattern if part of image is not displayed on the sink device. Setting parameters for Image position and Image size on the output side will be adjusted in order to present the test pattern appropriately on the display device.

Use "arrow" buttons (◀, ▶, ▲, ▼) to scroll through the available patterns "COLOR BAR", "GRAY SCALE", "RAMP", and "ZEBRA". Some test patterns can be configured to scroll across the screen either vertically or horizontally. Scrolling speed can be set in increments of 3 PIXEL/FRAME. Speed can be set up to 30 PIXEL/FRAME with "▲" and "▼" buttons.

[See: 9.3 Output position, size, and masking]

[See: 9.3.1 Output resolution]

[See: 9.3.3 Image position]

[See: 9.3.4 Image size]

[See: 9.3.5 Cropping]

### 9.3.8 Image Initialization

---

Menu	Top→OUTPUT IMAGE→IMAGE INITIALIZATION
Setting for	ALL, MAIN1, MAIN2, PinP1, PinP2 [PinP: PATTERN 1 to PATTERN 5]
Setting value	NO [Default], YES

The following settings are initialized:

- 9.3.3 Image position
- 9.3.4 Image size
- 9.3.5 Cropping

To initialize the setting, select "YES" and press the "MENU/ENTER" button. Note that settings cannot be restored once initialized.

If "PinP" is selected with PinP disabled, "NOT AVAILABLE NOW" will appear on the front display.

## 9.4 Output

Settings for video output and output connectors

### 9.4.1 Presence of output signal for when signal is input

Menu  Top→OUTPUT SETTINGS→OUTPUT SIGNAL  
 Setting for  ALL,HDMI OUT1A, HDBT OUT1B, HDMI OUT2A, HDBT OUT2B  
 Setting value  SOURCE [Default], BLACK, OFF

**[Table 9.5] Presence of output signal for when signal is input**

Setting value	Description
SOURCE [Default]	Input video signal
BLACK	Black video signal
OFF	Stops outputting synchronous signal and stops supplying power.

The same video is output to the HDMI and HDBaseT output connectors. Output video can be selected for each output.

If one output is set to "BLACK", the other can be used as preview.

If "OFF" is selected, for connected sink devices, standby mode may be available.

### 9.4.2 Presence of output signal for when no signal is input

Menu  Top→OUTPUT SETTINGS→NO SIGNAL IMAGE  
 Setting for  MAIN1, MAIN2, PinP1, PinP2  
 Setting value

**[Table 9.6] Presence of output signal for when no signal is input**

Setting value	MAIN	PinP	Remarks
BLUE [Default]	✓	✓	
BLACK	✓	✓	
OFF	✓	N/A	Synchronous signal is not output
BITMAP1 BITMAP2 BITMAP3 BITMAP4	✓	✓	The saved bitmap is output. 【See: 9.17 Bitmap】
BACKGROUND COLOR	✓	N/A	Color set in "9.3.6 Background color" is output

For "BITMAP1" to "BITMAP4", bitmap numbers that are saved as bitmap can be set.

### 9.4.3 HDCP output

Menu Top→OUTPUT SETTINGS→HDCP OUTPUT MODE  
 Setting for ALL, HDMI OUT1A, HDBT OUT1B, HDMI OUT2A, HDBT OUT2B  
 Setting value

**[Table 9.7] HDCP output mode**

Setting value	Description
ALWAYS [Default]	Always outputs HDCP.
HDCP INPUT ONLY	Encrypts HDCP only if the input signal has HDCP. However, if an input is changed from one channel to another and HDCP authentication status is changed, the MSD-S starts HDCP authentication again. This action may temporarily delay the output of video and audio.
DISABLE	Does not encrypt HDCP. Only non-HDCP-compliant input signal can be output.

You can set the HDCP output for when an HDCP-compliant sink device is connected.  
 Normally set this function to "ALWAYS".

### 9.4.4 HDCP retries

Menu Top→OUTPUT SETTINGS→HDCP RETRY  
 Setting for ALL, HDMI OUT1A, HDBT OUT1B, HDMI OUT2A, HDBT OUT2B  
 Setting value ETERNITY : Retries until succeed [Default]  
 0 to 100 : 0 to 100 times

You can set the number of HDCP retries.  
 If an HDCP-compliant sink device is connected", HDCP is authorized according to HDCP output mode setting.

**[See: 9.4.3 HDCP output]**

Normally, set this menu to "ETERNITY" to retry the authentication automatically after the first authentication fails. However, you can set the number of retries manually. (If retry is not succeeded even after the MSD-S retries for the set number of retry times, video and audio with HDCP are not output.)

Press the "MENU/ENTER" button to apply the setting.

### 9.4.5 Connection Reset

---

Menu	Top→OUTPUT SETTINGS→CONNECTION RESET
Setting for	HDMI OUT1A, HDBT OUT1B, HDMI OUT2A, HDBT OUT2B
Setting value	NO [Default], YES

For digital systems, some problems, such as an HDCP authentication error, can often be recovered by physically disconnecting and reconnecting the digital cables. However, the Connection Reset feature will fix these problems automatically without the need to physically plug and unplug the cables. It creates the same condition as if the cable were physically disconnected and reconnected.

Select "YES" and press the "MENU/ENTER" button to perform this feature.

### 9.4.6 Output equalizer

---

Menu	Top→OUTPUT SETTINGS→SIGNAL EQUALIZATION
Setting for	ALL, HDMI OUT1A, HDMI OUT2A
Setting value	

[Table 9.8] Output equalizer setting

Setting value	Equalization	Cable length*	
		Shorter than 33 ft. (10 m)	33 ft. (10 m) or longer
OFF [Default]	No equalization	✓	N/A
LOW	Low	✓	✓
MIDDLE	Middle	✓	✓
HIGH	High	N/A	✓

\* IDK's cable (24 AWG) was used

Each HDMI output connector includes an equalizer that compensates for signal attenuation when long HDMI cables are connected.

If a cable equalizer, active cable, or the like is connected, the MSD-S may not equalize output correctly. In such a case, set this menu to "OFF".

### 9.4.7 Output format

Menu	Top→OUTPUT SETTINGS→SIGNAL FORMAT
Setting for	ALL, HDMI OUT1A, HDBT OUT1B, HDMI OUT2A, HDBT OUT2B
Setting value	<ul style="list-style-type: none"> <li>• HDMI YCbCr 4:4:4 MODE [Default]</li> <li>• HDMI YCbCr 4:2:2 MODE</li> <li>• HDMI RGB MODE</li> <li>• DVI MODE</li> </ul>

You can select an output signal mode and color space of the output video.

The MSD-S selects the optimal output mode for the connected sink device according to the following priority table:

Higher priority	HDMI YCbCr 4:4:4 MODE
	HDMI YCbCr 4:2:2 MODE
	HDMI RGB MODE
Lower priority	DVI MODE

If "DVI MODE" is selected, digital audio is not output.

### 9.4.8 HDBaseT output long reach mode

Menu	Top→OUTPUT SETTINGS→HDBT LONG REACH MODE
Setting for	ALL, HDBT OUT1B, HDBT OUT2B
Setting value	OFF : Long reach mode OFF Up to 328 ft. (100 m) [Default] ON : Long reach mode ON Up to 492 ft. (150 m)

You can enable/disable long reach mode for HDBaseT output.

With long reach mode, up to 1080p (24 bit)/dot clock 148 MHz is supported when using with IDK's HDBaseT product.

Select a supported output format.

【See: 9.3.1 Output resolution】

【See: 9.4.9 Deep Color output】

### 9.4.9 Deep Color output

Menu	Top→OUTPUT SETTINGS→DEEP COLOR
Setting for	ALL, HDMI OUT1A, HDBT OUT1B, HDMI OUT2A, HDBT OUT2B
Setting value	24-BIT COLOR [Default], 30-BIT COLOR

You can select the color depth of HDMI signal.

"30-BIT COLOR": signals are output with "30-BIT COLOR" only if a sink device supporting Deep Color is connected.

Since the transmission clock of "30-BIT COLOR" is faster than that of "24-BIT COLOR", noise may occur if a poor-quality cable or long cable is connected. In those cases, the noise may be removed by selecting "24-BIT COLOR".

### 9.4.10 Window transition effect

---

Menu	Top→OUTPUT SETTINGS→VIDEO SWITCHING EFFECT
Setting for	MAIN1, MAIN2, PinP1, PinP2
Setting value	FREEZE→FADE OUT-IN [Default], FADE OUT-IN, CUT

You can select a window transition effect for when the video inputs are switched.  
If Automatic detection of video input interruption is set to "ON" and input signal is disconnected, this setting will be applied.

[See: 9.6.6 Automatic detection of video input interruption]

### 9.4.11 Window transition speed

---

Menu	Top→OUTPUT SETTINGS→SWITCHING EFFECT SPEED
Setting for	ALL, MAIN1, MAIN2, PinP1, PinP2
Setting value	100ms to 2000ms (by 10ms) [Default] 350ms

You can set the window transition speed for "FADE OUT/IN" when input channels are switched.  
The setting will also be applied when Automatic detection of video input interruption is set to "ON".

[See: 9.6.6 Automatic detection of video input interruption]

### 9.4.12 Sink device EDID check

Menu Top→OUTPUT SETTINGS→EDID ERR. OUTPUT MODE  
 Setting for ALL, HDMI OUT1A, HDBT OUT1B, HDMI OUT2A, HDBT OUT2B  
 Setting value

[Table 9.9] Sink device EDID check

Setting value	Description
CHECKSUM DISABLE [Default]	Ignores EDID checksum error. In case of EDID load error, the sink device is treated as a DVI device.
ENABLE	In case of EDID load error or checksum error, the sink device is treated as a DVI device.
ALL DISABLE	Ignores sink EDID and follows the MSD-S's setting.

The MSD-S gets EDID from the sink device and determines if the sink device is an HDMI device or DVI device. However, if the MSD-S cannot get EDID for some reasons, problems such as no audio output and the like may occur. Select "CHECKSUM DISABLE" or "ALL DISABLE" to output video and audio signals.

【See: 9.4.7 Output format】

### 9.4.13 CEC connection

Menu Top→OUTPUT SETTINGS→CEC CONNECTION  
 Setting for HDMI OUT1A, HDBT OUT1B, HDMI OUT2A, HDBT OUT2B  
 Setting value

[Table 9.10] CEC connection

Setting value	Input to be connected
NOT CONNECTED [Default]	Not connected CEC is not used.
IN1 to IN5	Specified input channel
SELECTED CHANNEL	Selected input channel

You can set the CEC connection for when a CEC-supported device is connected to HDMI input connector.

Press the "MENU/ENTER" button to apply the setting.

If you do not use CEC, select "NOT CONNECTED".

With CEC connection, if a sink device that is connected to an output connector is changed (for example, powering on/off) or CEC connection is changed, the MSD-S changes the address of the connected device. In this case, the source device stops outputting video temporarily.

CEC connections take place on a one-to-one basis. Multiple HDMI inputs/outputs cannot be connected to the HDBaseT output. If the same HDMI input is set to connect to multiple HDMI and HDBaseT outputs, a channel is selected automatically in alphabetical or numerical order and the other outputs will not be connected.

## 9.5 Input position, size, and cropping

Image position, size, and cropping are set from input side and output side.

【See: 9.3 Output position, size, and masking】

### 9.5.1 Aspect ratio

Menu Top→INPUT IMAGE→ASPECT RATIO

Setting for IN1 to IN7 for each input signal

Setting value

**[Table 9.11] Restoring aspect ratio (For input signal)**

Setting value	TV signal	PC signal
AUTO-1 [Default]	Follows sink device aspect ratio and its setting automatically. When letter box signal is input, video is output at the following aspect: "AUTO-1" : 16:9 or 14:9	
AUTO-2	"AUTO-2" : 4:3 Fixes mismatch in aspect ratio between a source and sink device automatically.	
4:3	4:3	Follows input signal aspect ratio
16:9	16:9	
14:9	14:9	
16:9 LETTER BOX	16:9 LETTER BOX	
14:9 LETTER BOX	14:9 LETTER BOX	
4:3 SIDE PANEL	4:3 SIDE PANEL	
14:9 SIDE PANEL	14:9 SIDE PANEL	
FULL	Provides a full screen output	
THROUGH	Displays input pixels	

You can set the aspect ratio for each video input.







Normally, no problem occurs if you set the aspect ratio to "AUTO-1", but some DVD players and other devices display subtitles or setup menus outside of the normal display area. In such cases, set this menu to "AUTO-2" to display the entire area of the video signals.

【See: 9.3.2 Aspect ratio for sink device】

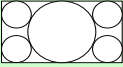
【See: 9.5.2 Aspect ratio control】

## 9.5.2 Aspect ratio control

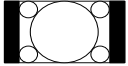
Menu	Top→INPUT IMAGE→ASPECT RATIO CONTROL
Setting for	IN1 to IN7 for each input signal
Setting value	L-BOX/S-PANEL : Letter box/side panel [Default] Maximizes the input video without cutting off and outputs the set background color on blank space. S-CUT/TB-CUT : Side cut/top bottom cut Crops part of input video and does not output background color. 【See: 9.3.2 Aspect ratio for sink device】 【See: 9.5.1 Aspect ratio】 【See: 9.3.6 Background color】

Input signal	Output signal	
	L-BOX/S-PANEL [Default]	S-CUT/TB-CUT
16:9 content on a 4:3 sink device 	Letter box 	Side cut 
4:3 content on a 16:9 sink device 	Side panel 	Top/bottom cut 

[Fig. 9.10] Restoring aspect ratio

## 9.5.3 Overscan

Menu	Top→INPUT IMAGE→OVERSCAN
Setting for	IN1 to IN7 for each input signal
Setting value	100% to 115% [Default] SDTV: 105%, HDTV/PC: 100%

You can create an enlarged display of the input video.

## 9.5.4 Image position

Menu Top→INPUT IMAGE→IMAGE POSITION

Setting for IN1 to IN7 for each input signal

Setting value

Horizontal position : -Horizontal input size to +Horizontal output resolution [by 1 pixel] [Default] 0

Vertical position : -Vertical input size to +Vertical output resolution [by 1 line] [Default] 0

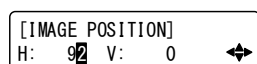

[Fig. 9.11] Setting image position page

You can change the position of the displayed video image.

The image position is based on the upper left quadrant of the window.

Image position range varies depending on the image size.

If the image position exceeds the limitation, the image position will be set automatically to a value within the parametric limitation.

【See: 9.5.5 Image size】

## 9.5.5 Image size

Menu Top→INPUT IMAGE→IMAGE SIZE

Setting for IN1 to IN7 for each input signal

Setting value

Horizontal size : Horizontal output resolution ÷4 to Horizontal output resolution ×4 [by 1 pixel]  
[Default] Horizontal output resolution

Vertical size : Vertical output resolution ÷4 to Vertical output resolution ×4 [by 1 line]  
[Default] Vertical output resolution

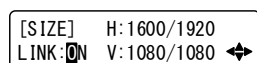

[Fig. 9.12] Setting image size page

You can use these settings to control the size of displayed video image.

The video size is scaled (quarte to quadruple) based on the upper left quadrant of the input image according to the OUT1 resolution.

If you set "LINK" to "ON", only settings of "H"(Horizontal) can be set and "V" (Vertical) is set automatically while retaining the current aspect ratio.

Numbers following "/" show the OUT1 resolution.

【See: 9.3.1 Output resolution】

【See: 9.5.4 Image position】

## 9.5.6 Cropping

Menu Top→INPUT IMAGE→IMAGE CROP

Setting for IN1 to IN7 for each input signal

Setting value

- Left side cropping : Horizontal input position to Right side cropping [by 1 pixel]  
[Default] 0
- Right side cropping : Left side cropping to Horizontal input position + Horizontal input size [by 1 pixel]  
[Default] Horizontal input size
- Top side cropping : Vertical input position to Bottom side cropping [by 1 line]  
[Default] 0
- Bottom side cropping : Top side cropping to Vertical input position + Vertical input size [by 1 line]  
[Default] Vertical input size

[IMAGE CROP] L: 30  
R:1920 T: 20 B:1080

[Fig. 9.13] Setting image size page

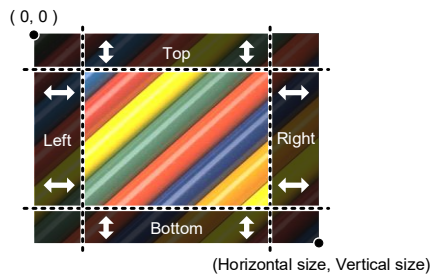

[Fig. 9.14] Input cropping

The settable range vary depending on the settings of image position and image size.  
If image position or image size is changed, cropping setting is also changed automatically with the display range kept.

【See: 9.5.4 Image position】

【See: 9.5.5 Image size】

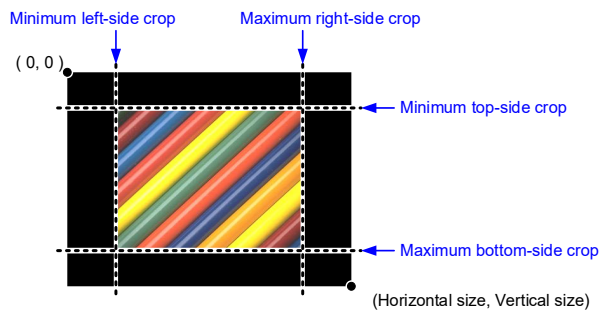

[Fig. 9.15] Setting input cropping

## 9.5.7 Image initialization

---

Menu	Top→INPUT IMAGE→IMAGE INITIALIZATION
Setting for	ALL, IN1 to IN7 for each input signal
Setting value	NO [Default], YES

The following settings are initialized:

- 9.5.1 Aspect ratio
- 9.5.3 Overscan
- 9.5.4 Image position
- 9.5.5 Image size
- 9.5.6 Cropping

To initialize the setting, select "YES" and press the "MENU/ENTER" button. Note that settings cannot be restored once initialized.

## 9.6 Input

Settings for video connector functions and input video detection.

### 9.6.1 DVI input connector signal

Menu	Top→INPUT SETTINGS→DVI-I: SIGNAL FORMAT
Setting for	ALL, IN6, IN7
Setting value	DIGITAL (HDMI and DVI signals are input) [Default], ANALOG

You can select signal format for DVI input.

If selecting "ANALOG", set the input signal format in "9.6.5 Analog input signal parameters".

### 9.6.2 No-signal input monitoring

Menu	Top→INPUT SETTINGS→NO INPUT MONITORING
Setting for	ALL, IN1 to IN5, IN6 (Digital), IN7 (Digital)
Setting value	OFF, 2000ms to 15000ms (by 100 ms.) [Default] 10000ms

If you change the EDID settings of the MSD-S or power the MSD-S off/on, the source device may not output a video signal. Use this menu to set the monitoring time. This is the interval beginning when a source device is not outputting a signal; and ending at the point when the MSD-S requests an output from that source device.

If "ANALOG" is selected for "9.6.1 DVI input connector signal", "NOT AVAILABLE NOW" will appear on the front display.

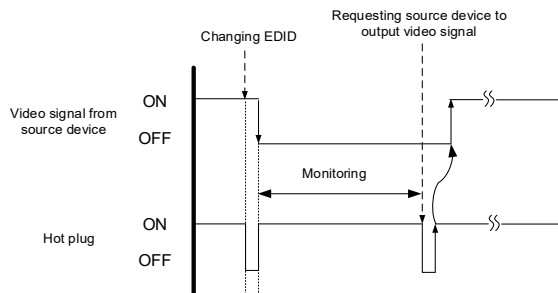

[Fig. 9.16] Monitoring absence of input

If you are using the monitor power-saving or dual monitor features on your PC, set this feature to “OFF”. This will avoid potentially unpredictable operation.

When using this feature, ensure that the “monitoring time” is set for a value greater than the amount of time needed for the source to provide an output signal.

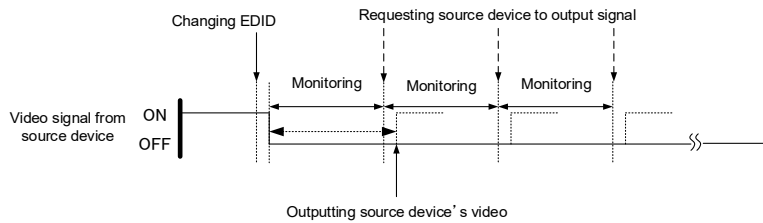

[Fig. 9.17] Repeating output reset

### 9.6.3 HDCP input

Menu	Top→INPUT SETTINGS→HDCP INPUT MODE
Setting for	ALL, IN1 to IN5, IN6 (Digital), IN7 (Digital)
Setting value	ENABLE : Enabling HDCP [Default] DISABLE : Disabling HDCP

Some source devices negotiate with the connected device to determine if HDCP encryption is supported. After this negotiation, the source device determines whether HDCP signal encryption is enforced or not. This process takes place with some source device, even if the content being presented is not copyright protected. The MSD-S is HDCP compliant, if it is connected to a display device that does not support HDCP, even unprotected AV content may not be successfully displayed. Under these circumstances and if the content is indeed not protected, the problem can be solved by setting this menu to “DISABLE.”

If “ANALOG” is selected for “9.6.1 DVI input connector signal”, “NOT AVAILABLE NOW” will appear on the front display.

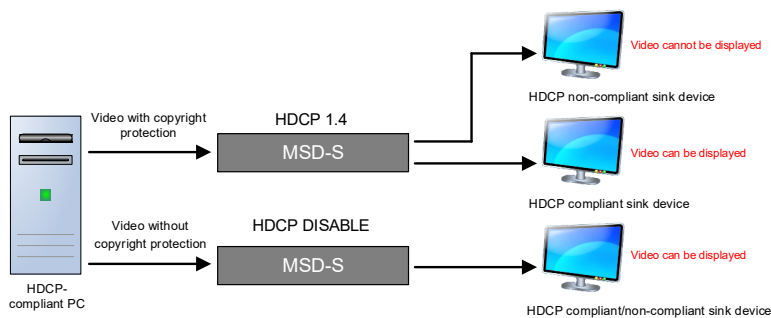

[Fig. 9.18] HDCP-compliant and HDCP non-compliant sink device

## 9.6.4 Input equalizer

Menu	Top→INPUT SETTINGS→SIGNAL EQUALIZATION
Setting for	ALL, IN1 to IN5
Setting value	ON [Default], OFF

Each HDMI output connector includes an equalizer that compensates for signal attenuation when long HDMI cables are connected.

If a cable equalizer, active cable, or the like is connected, the MSD-S may not equalize output correctly. In such a case, set this menu to "OFF".

## 9.6.5 Analog input signal parameters

Menu	Top→INPUT SETTINGS→ANALOG INPUT FORMAT
Setting for	IN6 (Analog), IN7 (Analog) for each input signal
Setting value	

[Table 9.12] Analog input signal parameters

Setting value	Analog input signal parameters
AUTO [Default]	Automatic
RGB	Analog RGB signal
YPbPr	Analog YPbPr signal

You can set the type of analog video input signal.

If you select "AUTO", the type of input signals is detected automatically.

If "DIGITAL" is selected for "9.6.1 DVI input connector signal", "NOT AVAILABLE NOW" will appear on the front display.

## 9.6.6 Automatic detection of video input interruption

---

Menu	Top→INPUT SETTINGS→INTERRUPTION DETECTION
Setting for	ALL, IN1 to IN7
Setting value	ON [Default], OFF

The MSD-S stops outputting video immediately after input video signal is disconnected even for a moment. Use this feature to minimize switching artifacts produced by an external device connected to the MSD-S's input connector. The effect of this function is similar to switching the MSD-S's input.

- 9.4.10 Window transition effect
- 9.4.11 Window transition speed

If you select "ON" and are using a video input (VHS tapes or the like) with a poor quality signal, it's possible that the output will flash on and off. This is due to sync signal distortion that can be interpreted as periods of time without signal presence. In this case, set this menu to "OFF".

Even if you set this feature to "ON", distorted video cannot be corrected completely when input video signals are lost. Especially if you set "**9.4.10 Window transition effect**" to an option other than "CUT", noises or black bars may be output at the time of fading out.

### 9.6.7 Fixing settings for each input signal

Menu Top→INPUT SETTINGS→SIGNAL SETTING MODE  
 Setting for IN1 to IN7  
 Setting value

**[Table 9.13] Input signal for output video**

Setting mode		Setting value	Description
SELECTED [Default]	ASPECT RATIO	OFF, ON(FIXED) [Default] OFF	Aspect ratio, analog input signal type and audio input level can be set individually.
	ANALOG INPUT FORMAT	OFF, ON(FIXED) [Default] ON(FIXED)	
	INPUT LEVEL OFFSET	OFF, ON(FIXED) [Default] ON(FIXED)	
ALL FIXED	—	—	Settings is not changed even if input signal is changed.

OFF : Settings saved for each input signal are used to format the video output.

ON(FIXED) : Current settings are used to format the video output.

The MSD-S continuously monitors the input signals. If a particular input signal that has been presented to the MSD-S before is input again, the MSD-S will output the signal at the same size and quality as during its previous use.

You can select the setting saved for each signal or the current setting.

【See: 9.2 Input signal automatic detection】

**[Table 9.14] Individual settings for each digital or analog signal**

Setting	Digital signal	Analog signal	Reference
ASPECT RATIO	Can be set	Can be set	9.5.1 Aspect ratio
ANALOG INPUT FORMAT	Cannot be set	Can be set	9.6.5 Analog input signal parameters
INPUT LEVEL OFFSET	Can be set	Cannot be set	9.11.2 Input audio level offset

## 9.7 Input timing

The signal timing of input video can be displayed and adjusted.

The MSD-S recalls the optimal table from its built-in library of tables and adjusts the input timing automatically, you typically will not need to change settings in this menu. However, if signals which are not registered in the MSD-S tables are introduced to the input or if part of the video image is cut off while relying on the standard table registered in the MSD-S, you may optimize the input timing parameters manually.

For digital inputs, you typically do not need to manually set timing parameters, but if part of the video image is cut off, you may make fine adjustments as required.

**[Table 9.15] Settable items**

Menu	Input signal	Analog RGB YPbPr	Digital
ANALOG MEASUREMENT			
Automatic measurement		Can be set	Cannot be set
H TOTAL PIXELS			
The total number of horizontal pixels		Can be set	※
H START POSITION			
Horizontal start position		Can be set	Can be set
H ACTIVE			
Horizontal active area		Can be set	Can be set
V START POSITION			
Vertical start position		Can be set	Can be set
V ACTIVE			
Vertical active area		Can be set	Can be set
START POSITION DETECT.			
Automatic measurement of start position		Can be set	Cannot be set
UNREGISTERED SIGNAL			
Automatic setting of input timing		Can be set	Cannot be set
INPUT TIMING INIT.			
Initializing digital input timing		Cannot be set	Can be set
RECALL ANALOG SETTINGS			
Recalling analog input timing		Can be set	Cannot be set
STORE ANALOG SETTINGS			
Saving analog input timing		Can be set	Cannot be set
ANALOG SIGNAL TRACKING			
Tracking		Can be set	Cannot be set

※Only automatic measurement result can be displayed.

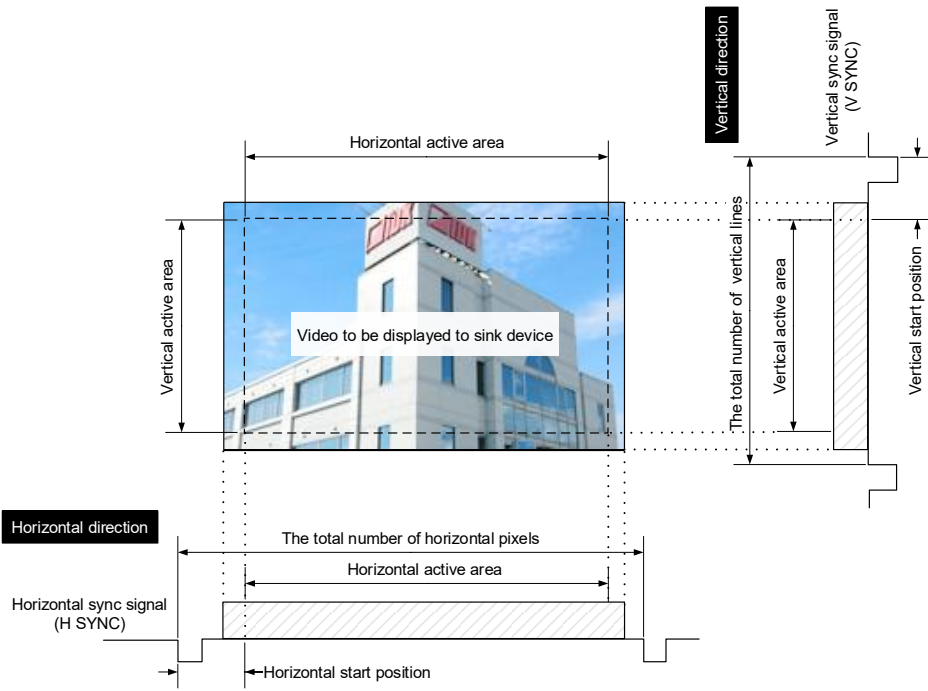

[Fig. 9.19] Input area

### 9.7.1 Automatic measurement

Menu Top→INPUT TIMING→ANALOG MEASUREMENT

Setting for IN6 (Analog), IN7 (Analog) for each input signal

Setting value

- NORMAL MODE [Default]
- NEXT ASPECT
- 4:3
- 5:4
- 5:3
- 16:9
- 16:10

Analog RGB/analog YPbPr input video is measured to set the following menu automatically.

- 9.7.2 The total number of horizontal pixels
- 9.7.3 Horizontal start position
- 9.7.4 Horizontal active area
- 9.7.5 Vertical start position
- 9.7.6 Vertical active area
- 9.7.12 Tracking

•Can be measured:

- Input video contacts the circumscribed rectangle.
- Brightness of input video is 25% or more.

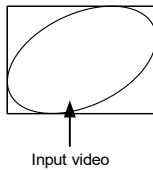
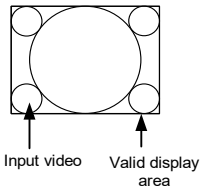

•Cannot be measured:

- Right and left sides of input video do not touch the circumscribed rectangle.
- Brightness of input video is 24% or less.

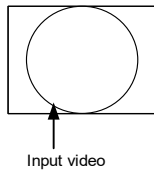

[Fig. 9.20] Conditions of automatic measurement

By selecting "NORMAL MODE", the MSD-S performs automatic measurement of the start position and active area. If edges of video are not displayed correctly, use this mode to set the start position and active area automatically.

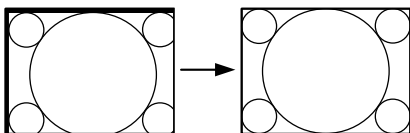

If the input video is not recognized correctly like above, it can adjust by executing "NORMAL MODE" automatic input measurement.

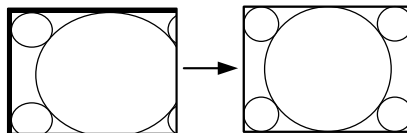

If the setting of active area is not correct and it cannot adjust only by start position, the active area is also adjusted by executing automatic input measurement.

[Fig. 9.21] Automatic measurement by using "NORMAL MODE"

If the total number of horizontal pixels is not correct, the aspect ratio is not matched even though automatic measurement is set to "NORMAL MODE". In this case, select "NEXT ASPECT" (Auto measurement taking into account aspect ratio) for the measurement function. If you know the aspect ratio of the input signal, you can directly specify the aspect ratio to correctly perform automatic measurement.

If the input signals are not registered in the MSD-S, it is recommended to use this function.

If only start position is changed, "NORMAL END" is displayed. If active area is changed if "NORMAL MODE" is selected or if "NEXT ASPECT" or aspect ratio is specified directly, the set resolution is displayed.

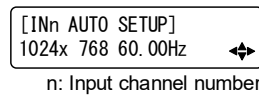

**[Fig. 9.22] Automatic measurement**

If there is no input signal on the selected input channel, "NOT AVAILABLE NOW" will appear on the front display.

【See: 9.6.1 DVI input connector signal】

Press the "MENU/ENTER" button to perform automatic measurement.

In case the aspect ratio does not match or the video is displayed in a position far from the correct position, set the following input timing:

- 9.7.2 The total number of horizontal pixels
- 9.7.3 Horizontal start position
- 9.7.4 Horizontal active area
- 9.7.5 Vertical start position
- 9.7.6 Vertical active area

■ **Operation from front buttons**

You can execute automatic measurement in "NORMAL MODE" by pressing for two seconds or longer. If you want to execute the automatic measurement in "NEXT ASPECT", press the same button for four seconds or longer.

Once automatic measurement is executed, it will be executed just by pressing the desired Input selection button (you do not have to press and hold the button). Five seconds after the last automatic measurement, this mode will be disabled.

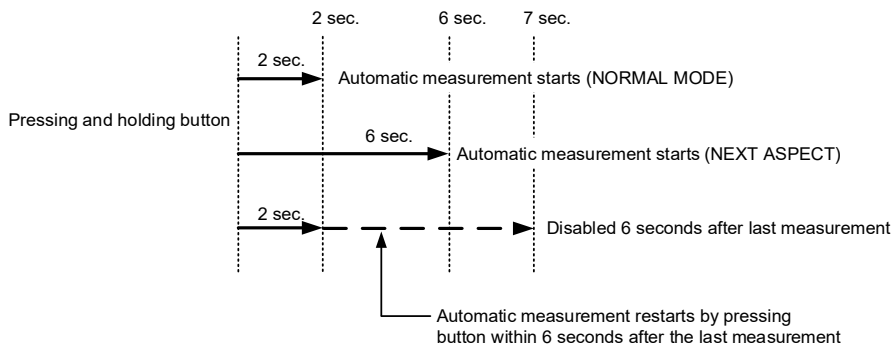

[Fig. 9.23] Automatic measurement using front button

## 9.7.2 The total number of horizontal pixels

Menu	Top→INPUT TIMING→H TOTAL PIXELS
Setting for	IN1 to IN7 for each input signal
Setting value	

**[Table 9.16] The total number of horizontal pixels**

Input signal (Analog RGB/Analog YPbPr)	Setting value
Interlaced signal	400PIXEL to 4125PIXEL [Default] varies depending on the input signal The sampling clock is within the range of 13 MHz to 82.5 MHz.
Non-interlaced signal	400PIXEL to 4125PIXEL [Default] varies depending on the input signal The sampling clock is within the range of 13 MHz to 165 MHz.

You can set the total number of horizontal pixels of analog RGB/analog YPbPr input video. The settable values vary depending on the sampling block (Horizontal sync frequency × the total number of horizontal pixels) of input signal. For analog video and digital signals, other input signals, this menu cannot be set; only the total number of horizontal pixels is displayed on the front display.

If no signal is input, "NOT AVAILABLE NOW" will appear on the front display.

## 9.7.3 Horizontal start position

Menu	Top→INPUT TIMING→H START POSITION
Setting for	IN1 to IN7 for each input signal
Setting value	64PIXEL to 2900PIXEL (The total number of horizontal pixels - Horizontal active area or less) [Default] Varies depending on the input signal.

You can set the horizontal start positions of input video. If the set value exceeds the limitation mentioned below, the display start position will be set automatically to a value within the parametric limitation.  
The total number of horizontal pixels > Horizontal active area > Horizontal start position

【See: 9.7.2 The total number of horizontal pixels】

【See: 9.7.4 Horizontal active area】

If no signal is input, "NOT AVAILABLE NOW" will appear on the front display.

### 9.7.4 Horizontal active area

---

Menu	Top→INPUT TIMING→H ACTIVE
Setting for	IN1 to IN7 for each input signal
Setting value	64PIXEL to 2900PIXEL (The total number of horizontal pixels - 64 or less) [Default] Varies depending on the input signal.

You can set the horizontal active area of input video.

For horizontal settings, the total number of horizontal pixels must be greater than the number representing the horizontal active area. Manually entered settings will be automatically limited to be within the MSD-S's accepted value range.

【See: 9.7.2 The total number of horizontal pixels】

If no signal is input, "NOT AVAILABLE NOW" will appear on the front display.

### 9.7.5 Vertical start position

---

Menu	Top→INPUT TIMING→V START POSITION
Setting for	IN1 to IN7 for each input signal
Setting value	10LINE to 2048LINE (The total number of vertical lines - Vertical active area or less) [Default] Varies depending on the input signal.

You can set the vertical start positions of input video.

If the set value exceeds the limitation mentioned below, the display start position will be set automatically to a value within the parametric limitation.

The total number of vertical lines > Vertical active area > Vertical start position

【See: 9.7.6 Vertical active area】

If no signal is input, "NOT AVAILABLE NOW" will appear on the front display.

### 9.7.6 Vertical active area

---

Menu	Top→INPUT TIMING→V ACTIVE
Setting for	IN1 to IN7 for each input signal
Setting value	10LINE to 2048LINE (The total number of vertical lines - 10 or less) [Default] Varies depending on the input signal.

You can set the vertical active area of input video.

If no signal is input, "NOT AVAILABLE NOW" will appear on the front display.

### 9.7.7 Automatic measurement of start position

Menu	Top→INPUT TIMING→START POSITION DETECT.
Setting for	IN6 (Analog), IN7 (Analog) for each input signal
Setting value	ALL OFF : Not measuring all inputs from the input automatically OFF : Not measuring the current input signal automatically ON : Measuring the current input signal automatically [Default]

PCs usually output video signals meeting the VESA standard, but some PCs output cut-off (a few dots from the VESA standard) signals. In such a case, if the video is output using the video format table in the MSD-S, the left edge may not be displayed or black line may be output.

If you set this menu to "ON", the MSD-S continually monitors analog input signals to identify the upper left portion of the image and then automatically adjusts formatting to place the image correctly on the display.

If no signal is input or "DIGITAL" is selected for "**9.6.1 DVI input connector signal**", "NOT AVAILABLE NOW" will appear on the front display.

For motion images, some content may not be displayed full screen, and the image position may be moved each time the automatic setting measurement is applied. In such a case, set this menu to "OFF".

As "OFF" and "ON" are saved for each input signal, it can be set according to the input signal. If you do not want this function for any resolution format, select "ALL OFF".

Only the start position is set by the automatic measurement feature listed in this menu.

If the total number of horizontal pixels and active area do not match, the lower right may be cut off or blackout may be output. In this case, adjust the whole screen by following automatic measurement. As the set value must not exceed the value set in start position, some video formats may be displayed with blackouts at the left side or top of the image.

【See: 9.7.1 Automatic measurement】

This menu can be set only if "**[Fig. 9.20] Conditions of automatic measurement**" is satisfactory.

Even if you set this menu feature to "ON", manual settings will be applied and the automatic measurement is not executed if you set any of the following menus: the total number of horizontal pixels, start position, and active area. If you set tracking, the manual setting is applied, and tracking is not set automatically when the automatic measurement is executed. When you execute automatic measurement, setting values or this menu will be valid again.

【See: 9.7.2 The total number of horizontal pixels】

【See: 9.7.3 Horizontal start position】

【See: 9.7.4 Horizontal active area】

【See: 9.7.5 Vertical start position】

【See: 9.7.6 Vertical active area】

【See: 9.7.12 Tracking】

### 9.7.8 Automatic setting of input timing

---

Menu	Top→INPUT TIMING→UNREGISTERED SIGNAL
Setting value	AUTO SETUP ON [Default], AUTO SETUP OFF

The MSD-S recalls the optimal table from the library of built-in tables and sets the input timing automatically. However, if unregistered analog signals are input, the input timing must be set. By setting this menu feature to "AUTO SETUP ON", automatic measurement is executed and the input timing is set automatically if analog signals that cannot be detected by the MSD-S are being introduced to a particular input for the first time.

【See: 9.7.1 Automatic measurement】

If "DIGITAL" is selected for "**9.6.1 DVI input connector signal**", "NOT AVAILABLE NOW" will appear on the front display.

If automatic measurement results in aspect ratio inconsistencies, set the following menus:

- 9.7.2 The total number of horizontal pixels
- 9.7.3 Horizontal start position
- 9.7.4 Horizontal active area
- 9.7.5 Vertical start position
- 9.7.6 Vertical active area

### 9.7.9 Initializing digital input timing

---

Menu	Top→INPUT TIMING→INPUT TIMING INIT.
Setting for	IN1 to IN5, IN6 (Digital), IN7 (Digital) (To be initialized for each input signal)

Use this menu to restore default input timing.

Press the "MENU/ENTER" button to apply the setting.  
Note that settings cannot be restored once initialized.

If no signal is input or "ANALOG" is selected for "**9.6.1 DVI input connector signal**", "NOT AVAILABLE NOW" will appear on the front display.

### 9.7.10 Recalling analog input timing

Menu	Top→INPUT TIMING→RECALL ANALOG SETTINGS
Setting for	IN6 (Analog), IN7 (Analog) for each input signal

You can recall device information of registered analog RGB/analog YPbPr input video.  
Perform this menu when the synchronous signal frequency is the same and multiple device data having different input timings are registered or you want to set the input timing again.

【See: 9.7.11 Saving analog input timing】

Press the "MENU/ENTER" button to apply the setting.

If no signal is input or "DIGITAL" is selected for "**9.6.1 DVI input connector signal**", "NOT AVAILABLE NOW" will appear on the front display.

### 9.7.11 Saving analog input timing

Menu	Top→INPUT TIMING→STORE ANALOG SETTINGS
Setting for	IN6 (Analog), IN7 (Analog) for each input signal
Setting value	No. 1 to No.99

You can register up to 99 analog RGB/analog YPbPr input timing settings, and you can name each device data up to 14 characters using ASCII code 20 to 7D.

If you do not name the device table and press the "MENU/ENTER" button, the input resolution will be the device table name automatically. If the device table name is already registered and press "MENU/ENTER" button without specifying device table name, the input timing is saved to the device table name without changing the device table name.

From the next time, video will be displayed at the registered timing when the same signal is input to other channels.

Press the "MENU/ENTER" button to apply the setting.

If no signal is input or "DIGITAL" is selected for "**9.6.1 DVI input connector signal**", "NOT AVAILABLE NOW" will appear on the front display.

### 9.7.12 Tracking

Menu	Top→INPUT TIMING→ANALOG SIGNAL TRACKING
Setting for	IN6 (Analog), IN7 (Analog) for each input signal
Setting value	0 to 63 [Default] 0

You can adjust the tracking of analog RGB/analog YPbPr input video.

If no signal is input or "DIGITAL" is selected for "**9.6.1 DVI input connector signal**", "NOT AVAILABLE NOW" will appear on the front display.

【See: 9.7.2 The total number of horizontal pixels】

## 9.8 Automatic input channel switching

When signal input status changes, the MSD-S can switch the input channel automatically. The switching priority can be set for each input.

### 9.8.1 Signal ON priority

Menu Top→AUTO SWITCHING→SIGNAL ON PRIORITY  
 Setting for ALL, MAIN1, MAIN2, PinP1, PinP2  
 Setting value

[Table 9.17] Automatic signal ON priority

Windows	Setting value	
	Input connector (IN)	Priority
ALL	IN1 to IN7	OFF (Disabled) [Default],
MAIN		1 (Highest) to 7 (Lowest)
PinP		

If signal input status changes from “OFF” to “ON”, the MSD-S automatically selects the input channel according to the set priority.

Press the “MENU/ENTER” button to apply the setting.

The MSD-S switches input signals automatically as follows:

- When input signal status of a channel changes from “OFF” to “ON” and that input channel has the same or a higher priority level than the currently-selected channel.
- or
- When video is not input to the current input channel having higher priority than the input channel that changes from “OFF” to “ON”.

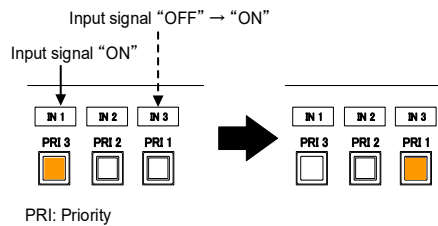

[Fig. 9.24] Automatic input channel switching “OFF” to “ON”

## 9.8.2 Signal OFF priority

Menu	Top→AUTO SWITCHING→SIGNAL OFF PRIORITY
Setting for	ALL, MAIN1, MAIN2, PinP1, PinP2
Setting value	

[Table 9.18] Automatic signal OFF priority

Windows	Setting value	
	Input connector (IN)	Priority
ALL	IN1 to IN7	OFF (Disabled) [Default],
MAIN		1 (Highest) to 7 (Lowest)
PinP		

Selects alternate input channel when the input signal of currently-selected channel changes from “ON” to “OFF”.

Press the “MENU/ENTER” button to apply the setting.

The MSD-S switches input signal automatically as follows:

- Switches to the input channel having input signal and highest priority.
- or
- If some channels have the same priority, the MSD-S switches to the lower numbered input channel having an active input signal.

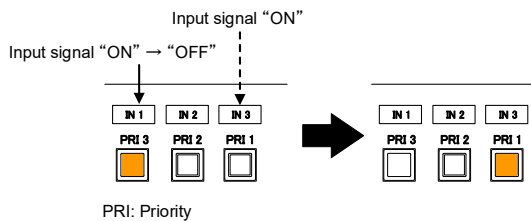

[Fig. 9.25] Automatic input channel switching “OFF” to “ON”

## 9.8.3 Ignoring duration after automatic switching

Menu	Top→AUTO SWITCHING→IGNORING DURATION
Setting for	ALL, MAIN1, MAIN2, PinP1, PinP2
Setting value	0s000ms to 999s999ms [Default] 0s000ms

You can set the time from when input channel is switched automatically until when the next automatic switching is performed. The automatic switching is not performed during the set time even if input channel is changed within the set duration.

## 9.8.4 Channel switching mode of automatic switching

---

Menu	Top→AUTO SWHITCING→SWITCHING MODE
Setting for	ALL, MAIN1, MAIN2
Setting value	V&A : Video & Audio [Default] VIDEO : Video AUDIO : Audio

You can set the channel switching mode when automatic switching is executed.

Selected video and audio are switched for input channel automatic switching.

This setting has priority regardless of channel switching mode that is set in "**9.20.2 Channel switching mode**".

## 9.9 Picture controls

Setting items for input channels are for correcting color bias.

Image quality to be output can be set for each input channel and output channel as follows:

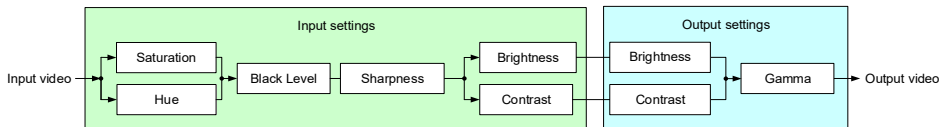

[Fig. 9.26] Picture controls

### 9.9.1 Output brightness

Menu	Top→PICTURE ADJUSTMENT→OUTPUT BRIGHTNESS
Setting for	ALL, MAIN1, MAIN2, PinP1, PinP2
Setting value	80% to 120% [Default] 100%

You can set the brightness level for each output signal.

### 9.9.2 Output contrast

Menu	Top→PICTURE ADJUSTMENT→OUTPUT CONTRAST
Setting for	ALL, MAIN1, MAIN2, PinP1, PinP2
Setting value	R/G/B: 0% to 200% [Default] R/G/B: 100%

You can set the contrast for the output video image.

If you set "LINK" to "ON", only the setting for "R" can be adjusted, and in this mode, "G" and "B" will automatically track the setting of "R".

### 9.9.3 Output gamma

Menu	Top→PICTURE ADJUSTMENT→OUTPUT GAMMA
Setting for	ALL, MAIN1, MAIN2, PinP1, PinP2
Setting value	0.1 to 3.0 (by 0.1) [Default] 1.0

You can adjust the gamma curve independently or each output signal.

## 9.9.4 Output video correction initialization

---

Menu	Top→PICTURE ADJUSTMENT→OUTPUT SETTING INIT.
Setting for	ALL, MAIN1, MAIN2, PinP1, PinP2
Setting value	NO [Default], YES

The following settings are initialized:

- 9.9.1 Output brightness
- 9.9.2 Output contrast
- 9.9.3 Output gamma

To initialize the setting, select "YES" and press the "MENU/ENTER" button. Note that settings cannot be restored once initialized.

## 9.9.5 Input sharpness

---

Menu	Top→PICTURE ADJUSTMENT→INPUT SHARPNESS
Setting for	IN1 to IN7 for each input signal
Setting value	-5 to 15 [Default] 0

You can set the desired level of sharpness for each input signal.

## 9.9.6 Input brightness

---

Menu	Top→PICTURE ADJUSTMENT→INPUT BRIGHTNESS
Setting for	IN1 to IN7 for each input signal
Setting value	80% to 120% [Default] 100%

You can set the brightness level for each input signal.

## 9.9.7 Input contrast

---

Menu	Top→PICTURE ADJUSTMENT→INPUT CONTRAST
Setting for	IN1 to IN7 for each input signal
Setting value	R/G/B: 0% to 200% [Default] R/G/B: 100%

You can set the contrast for the input video image.

If you set "LINK" to "ON", only the setting for "R" can be adjusted, and in this mode, "G" and "B" will automatically track the setting of "R".

### 9.9.8 Input hue

---

Menu	Top→PICTURE ADJUSTMENT→INPUT HUE
Setting for	IN1 to IN7 for each input signal
Setting value	0° to 359° [Default] 0°

You can set the color HUE for each input signal.

### 9.9.9 Input saturation

---

Menu	Top→PICTURE ADJUSTMENT→INPUT SATURATION
Setting for	IN1 to IN7 for each input signal
Setting value	0% (Monochrome) to 200% [Default] 100%

You can set the color saturation independently for each input signal.

### 9.9.10 Input black level

---

Menu	Top→PICTURE ADJUSTMENT→INPUT BLACK LEVEL
Setting for	IN1 to IN7 for each input signal
Setting value	-10.0% to 10.0% (by 0.5%) [Default] 0.0%

You can adjust the black level independently for each input signal.

### 9.9.11 Input video correction initialization

---

Menu	Top→PICTURE ADJUSTMENT→INPUT SETTING INIT.
Setting for	ALL, IN1 to IN7 (To be initialized for each input signal)
Setting value	NO [Default], YES

The following settings are initialized:

- 9.9.5 Input sharpness
- 9.9.6 Input brightness
- 9.9.7 Input contrast
- 9.9.8 Input hue
- 9.9.9 Input saturation
- 9.9.10 Input black level

To initialize the setting, select "YES" and press the "MENU/ENTER" button. Note that settings cannot be restored once initialized.

## 9.10 Output audio

The following audio formats are supported:

- Digital audio input/output: Multi-channel audio
- Digital audio output and analog audio output: Downmixed audio

■ **If multi-channel LPCM signal is input to digital audio:**

For sink device, analog audio that does not support multi-channel LPCM signal, 2-channels (ch) that are set in "9.10.6 Multi-channel audio output" or downmixed audio will be output.

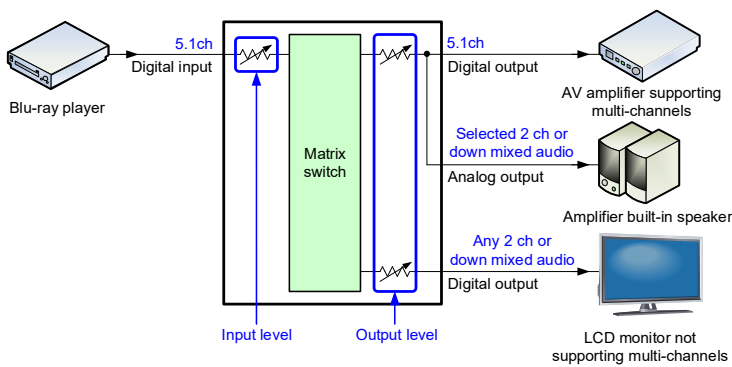

[Fig. 9.27] Multi-channel LPCM input

■ **If bitstream signal is input to digital audio:**

Input audio is output to digital audio connector. It is not output to analog audio; audio volume cannot be adjusted.

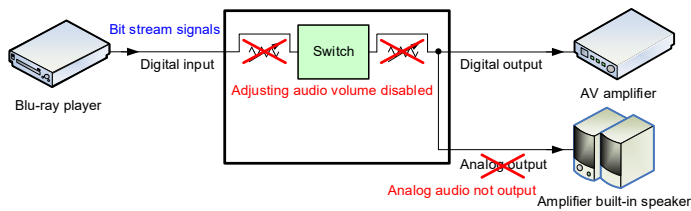

[Fig. 9.28] Bit stream signal input

### 9.10.1 Output audio

---

Menu	Top→OUTPUT AUDIO SETTINGS→OUTPUT SIGNAL
Setting for	ALL, HDMI OUT1A, HDBT OUT1B, HDMI OUT2A, HDBT OUT2B, ANALOG OUT1, ANALOG OUT2
Setting value	ON [Default], OFF

You can set output audio control independently for each output connector.

### 9.10.2 Output audio level

---

Menu	Top→OUTPUT AUDIO SETTINGS→OUTPUT LEVEL
Setting for	ALL, OUT1, OUT2
Setting value	DIGITAL : -100dB to 10dB [Default] 0dB ANALOG: -100dB to 10dB [Default] 0dB

You can set the output audio level on the "AUDIO VOLUME" page of the front display.

[DIGITAL] 0dBu
-------------------

If you change the output level while the output audio mute is set to "ON", it will be unmuted.

If you set "9.20.9 Top page" to "AUDIO VOLUME", you can change the output level from the top page.

[【See: 9.10.3 Audio mute】](#)

[【See: 9.20.9 Top page】](#)

### 9.10.3 Audio mute

---

Menu	Top→OUTPUT AUDIO SETTINGS→MUTE
Setting for	ALL, OUT1, OUT2
Setting value	OFF [Default], ON

You can mute/unmute the output audio.

You can mute/unmute all audio outputs on the "AUDIO VOLUME" page of the front display.

[DIGITAL] MUTE 0dBu
------------------------

[【See: 9.20.9 Top page】](#)

### 9.10.4 Output Lip Sync

Menu	Top→OUTPUT AUDIO SETTINGS→LIP SYNC
Setting for	OUT1, OUT2
Setting value	0ms to 70ms [Default] 0ms

You can adjust the time gap between video (motion) and audio (sound).  
The total delay of input and output Lip Sync is up to 70 ms.

【See: 9.11.3 Input Lip Sync】

### 9.10.5 Sampling frequency

Menu	Top→OUTPUT AUDIO SETTINGS→SAMPLING FREQUENCY
Setting for	ALL, OUT1, OUT2
Setting value	

- AUTO-A [Default]      • 44.1kHz                      • 96kHz
- AUTO-B                      • 48kHz                      • 192kHz
- 32kHz                      • 88.2kHz

You can set the sampling frequency of digital audio output.

#### ■ “AUTO-A” or “AUTO-B”

Outputting digital audio at the maximum sampling frequency supported by the sink device that is connected to OUT A (HDMI for AUTO-A) or OUT B (HDBaseT for AUTO-B).

At this time, the sampling frequency that is actually output is displayed in parentheses. In case EDID cannot be read from the sink device, the sampling frequency that was used the last time is selected with “\*” on its right side.



Maximum sampling frequency

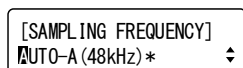

Sampling frequency used last time

### 9.10.6 Multi-channel audio output

Menu	Top→OUTPUT AUDIO SETTINGS→DOWNMIX		
Setting for	ALL, OUT1, OUT2		
Setting value	<ul style="list-style-type: none"> <li>• DOWNMIX [Default]</li> <li>• CH1/CH2 STEREO</li> <li>• CH3/CH4 STEREO</li> </ul>	<ul style="list-style-type: none"> <li>• CH5/CH6 STEREO</li> <li>• CH7/CH8 STEREO</li> <li>• CH1/CH2 MONO</li> </ul>	<ul style="list-style-type: none"> <li>• CH3/CH4 MONO</li> <li>• CH5/CH6 MONO</li> <li>• CH7/CH8 MONO</li> </ul>

When multi-channel LPCM audio is input, you can select output audio channels for analog audio output and a sink device that does not support multi-channel LPCM audio.

You can select audio from "DOWNMIX" (downmixed audio), "STEREO" (2-channel audio), or "MONO" (mixed 2-channel audio).

### 9.10.7 Multi-channel audio output priority

Menu	Top→OUTPUT AUDIO SETTINGS→OUTPUT PRIORITY	
Setting for	ALL, OUT1, OUT2	
Setting value	MULTI (Multi-channel) [Default], 2CH (Downmix)	

The MSD-S outputs the same audio to HDMI and HDBaseT output connectors.

Input multi-channel LPCM is output according to audio signal formats that are supported by sink devices.

"MULTI" : Multi-channel LPCM has priority to be output. If sink devices that support only 2-channel is connected to both outputs, down-mixed audio or 2-channel audio is output.

"2CH" : 2-channel audio has priority to be output. If sink devices that support multi-channel LPCM is connected to both outputs, multi-channel LPCM audio is output.

If no sink device is connected, audio is output same as a sink device that supports only 2-channel is connected.

**【See: 9.10.6 Multi-channel audio output】**

### 9.10.8 Test tone

Menu Top→OUTPUT AUDIO SETTINGS→TEST TONE  
 Setting for ALL, OUT1, OUT2  
 Setting value

**[Table 9.19] Test tone**

Setting value	Speaker
OFF [Default]	—
400Hz	<ul style="list-style-type: none"> <li>• ALL [Default]</li> <li>• LOW FREQUENCY EFFECT</li> </ul>
1kHz	<ul style="list-style-type: none"> <li>• FRONT L/R</li> <li>• FRONT CENTER</li> <li>• REAR L/R</li> <li>• REAR LEFT</li> <li>• REAR L/R CENTER</li> <li>• REAR RIGHT</li> <li>• FRONT LEFT</li> <li>• REAR LEFT CENTER</li> <li>• FRONT RIGHT</li> <li>• REAR RIGHT CENTER</li> </ul>

You can check the position of the speakers, since test tone also can be output only to specific speakers. For "LOW FREQUENCY EFFECT", only test tone of 30 Hz is output.

【See: 9.12.14 Speaker configuration】

## 9.11 Input audio

---

### 9.11.1 Input audio

---

Menu	Top→INPUT AUDIO SETTINGS→INPUT SIGNAL
Setting for	ALL, IN1 to IN7
Setting value	DIGITAL [Default], ANALOG1, ANALOG2, ANALOG3

You can select input audio for each input channel.

【See: 9.6.1 DVI input connector signal】

### 9.11.2 Input audio level offset

---

Menu	Top→INPUT AUDIO SETTINGS→INPUT LEVEL OFFSET
Setting for	DIGITAL IN1 to DIGITAL IN7 for each input signal, ANALOG1, ANALOG2, ANALOG3
Setting value	-100dB to 10dB [Default] 0dB

You can set the input audio offset.

You can correct the gap in input audio levels of each input signal, since input audio levels can be set for each input port.

### 9.11.3 Input Lip Sync

---

Menu	Top→INPUT AUDIO SETTINGS→LIP SYNC
Setting for	IN1 to IN7 for each input signal
Setting value	0ms to 70ms [Default] 0ms

You can adjust the time gap between video (motion) and audio (sound).

The total delay of input and output Lip Sync is up to 70 ms.

【See: 9.10.4 Output Lip Sync】

### 9.11.4 Stable input audio wait

---

Menu	Top→INPUT AUDIO SETTINGS→STABLE WAIT
Setting for	IN1 to IN7
Setting value	ON [Default], OFF

This feature is for waiting until input audio becomes stable in order to avoid popping noise when digital audio source is turned on or the like.

If initial sound cannot be output, disable this feature. In such a case, however, unstable input signal may become noise at the start.

## 9.12 EDID

EDID can be set using the following data:

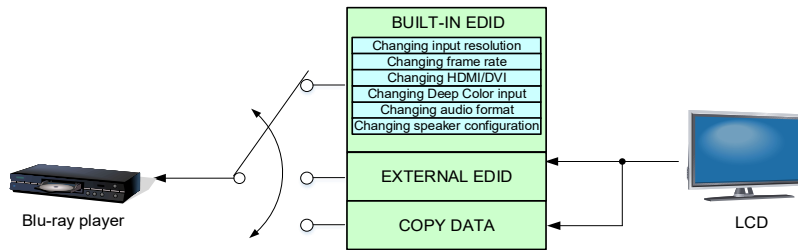

[Fig. 9.29] Setting EDID

### 9.12.1 EDID selection

Menu	Top→EDID SETTINGS→EDID SELECTION		
Setting for	ALL, IN1 to IN5, IN6 (Digital), IN7 (Digital)		
Setting value	<ul style="list-style-type: none"> <li>• BUILT-IN EDID [Default]</li> <li>• EXTERNAL EDID OUT1B</li> <li>• EXTERNAL EDID OUT2B</li> <li>• EXTERNAL EDID OUT1A</li> <li>• EXTERNAL EDID OUT2A</li> <li>• COPY DATA1 to COPY DATA8</li> </ul>		

You can set the EDID that will be sent to source device.  
 Only if "BUILT-IN EDID" is selected, you can set "9.12 EDID".

Press the "MENU/ENTER" button to apply the setting.

If "ANALOG" is selected for "9.6.1 DVI input connector signal", "NOT AVAILABLE NOW" will appear on the front display.

## 9.12.2 Input resolution

Menu Top→EDID SETTINGS→RESOLUTION

Setting for ALL, IN1 to IN7

Setting value

- |                            |                     |                      |
|----------------------------|---------------------|----------------------|
| • QWXGA(2048x1152)         | • WXGA++(1600x900)  | • WXGA(1280x800)     |
| • WUXGA(1920x1200)         | • WXGA+(1440x900)   | • WXGA(1280x768)     |
| • 1080p(1920x1080)         | • SXGA+(1400x1050)  | • 720p(1280x720)     |
| • VESA1080p(1920x1080)     | • WXGA(1366x768)    | • VESA720p(1280x720) |
| • 1080i(1920x1080)         | • WXGA(1360x768)    | • XGA(1024x768)      |
| • WSXGA+(1680x1050)        | • SXGA(1280x1024)   | • SVGA(800x600)      |
| • UXGA(1600x1200)          | • QuadVGA(1280x960) |                      |
| [Default] 1080p(1920x1080) |                     |                      |

You can set the supported video resolution.

This setting will also be applied for controlling output resolution when AV devices (such as Blu-ray players) are connected via HDMI.

For digital input, this setting will be valid only if "BUILT-IN EDID" is selected.

【See: 9.12.1 EDID selection】

Press the "MENU/ENTER" button to apply the setting.

Timing of 720p, 1080i, and 1080p is the same as that of HD signal meeting the CEA-861 standard.

For other resolutions, timing parameters meet the VESA DMT or VESA CVT standards.

The maximum available resolution is set for EDID, but the lower resolutions are also supported.

【See: [Table 9.20] Supported resolution】

[Table 9.20] Supported resolution

Input resolution setting \ Supported resolution	640×480	800×600	1024×768	1280×720	VESA720p	1280×768	1280×800	1280×960	1280×1024	1360×768	1366×768	1400×1050	1440×900	1600×900	1600×1200	1680×1050	1920×1080i	1920×1080p	VESA1080p	1920×1200	2048×1152
800x600	Y	Y	N	N	N	N	N	N	N	N	N	N	N	N	N	N	N	N	N	N	N
1024x768	Y	Y	Y	N	N	N	N	N	N	N	N	N	N	N	N	N	N	N	N	N	N
1280x720	Y	Y	Y	Y	N	N	N	N	N	N	N	N	N	N	N	N	N	N	N	N	N
VESA720	Y	Y	Y	N	Y	N	N	N	N	N	N	N	N	N	N	N	N	N	N	N	N
1280x768	Y	Y	Y	Y	N	Y	N	N	N	N	N	N	N	N	N	N	N	N	N	N	N
1280x800	Y	Y	Y	Y	N	Y	Y	N	N	N	N	N	N	N	N	N	N	N	N	N	N
1280x960	Y	Y	Y	Y	N	Y	Y	Y	N	N	N	N	N	N	N	N	N	N	N	N	N
1280x1024	Y	Y	Y	Y	N	Y	Y	Y	Y	N	N	N	N	N	N	N	N	N	N	N	N
1360x768	Y	Y	Y	Y	N	Y	Y	Y	Y	Y	N	N	N	N	N	N	N	N	N	N	N
1366x768	Y	Y	Y	Y	N	Y	Y	Y	Y	N	Y	N	N	N	N	N	N	N	N	N	N
1400x1050	Y	Y	Y	Y	N	N	Y	Y	Y	N	Y	Y	N	N	N	N	N	N	N	N	N
1440x900	Y	Y	Y	Y	N	N	N	Y	Y	N	Y	Y	N	N	N	N	N	N	N	N	N
1600x900	Y	Y	Y	Y	N	N	Y	Y	Y	N	Y	Y	Y	Y	N	N	N	N	N	N	N
1600x1200	Y	Y	Y	Y	N	N	Y	Y	Y	N	Y	Y	Y	Y	Y	N	N	N	N	N	N
1680x1050	Y	Y	Y	Y	N	N	Y	Y	Y	N	Y	Y	Y	Y	Y	Y	N	N	N	N	N
1920x1080i	Y	Y	Y	Y	N	N	N	N	N	N	N	N	N	N	N	N	Y	N	N	N	N
1920x1080p	Y	Y	Y	Y	N	N	N	Y	Y	N	Y	Y	Y	Y	Y	Y	N	Y	N	N	N
VESA1080p	Y	Y	Y	Y	N	N	N	Y	Y	N	Y	Y	Y	Y	Y	Y	N	N	Y	N	N
1920x1200	Y	Y	Y	N	N	N	Y	Y	Y	N	N	Y	Y	Y	Y	Y	N	Y	N	Y	N
2048x1152	Y	Y	Y	N	N	N	N	Y	Y	N	N	Y	Y	Y	Y	Y	N	Y	N	Y	Y

Y: Supported, N: Not supported

### 9.12.3 Copying EDID

Menu	Top→EDID SETTINGS→SINK DEVICE EDID COPY
Setting for	HDMI OUT1A, HDBT OUT1B, HDMI OUT2A, HDBT OUT2B
Setting value	No.1 to No.8

EDID of sink device is loaded and saved to the MSD-S.

Up to eight EDID profiles can be saved.

Set the name of the EDID using ASCII code 20 to 7D (up to 10 characters).

“COPY DATA + Copied data number” is saved if you do not change the name.

Press the “MENU/ENTER” button to apply the setting.

If no sink device is connected to the selected output connector, a message, “UNCONNECTED”, appears.

### 9.12.4 HDMI/DVI

---

Menu	Top→EDID SETTINGS→SIGNAL FORMAT
Setting for	ALL, IN1 to IN5, IN6 (Digital), IN7 (Digital)
Setting value	HDMI [Default], DVI

You can select EDID signal format.

For HDMI, video and audio settings will be applied.

For DVI, settings of input resolution and frame rate will be applied.

【See: 9.12.2 Input resolution】

【See: 9.12.5 Frame rate】

This setting will be valid only if "BUILT-IN EDID" is selected for EDID in "9.12.1 EDID selection".

Press the "MENU/ENTER" button to apply the setting.

If "ANALOG" is selected for "9.6.1 DVI input connector signal", "NOT AVAILABLE NOW" will appear on the front display.

### 9.12.5 Frame rate

---

Menu	Top→EDID SETTINGS→FRAME RATE
Setting for	ALL, IN1 to IN7
Setting value	60Hz [Default], 50Hz

You can set the video frequency that is output from source device.

This setting will be valid only if "BUILT-IN EDID" is selected for EDID in "9.12.1 EDID selection".

Press the "MENU/ENTER" button to apply the setting.

### 9.12.6 Deep Color input

---

Menu	Top→EDID SETTINGS→DEEP COLOR
Setting for	ALL, IN1 to IN5, IN6 (Digital), IN7 (Digital)
Setting value	24-BIT COLOR [Default], 30-BIT COLOR

You can set the color depth that is output from the source device.

If you select "30-BIT COLOR", compared to "24-BIT COLOR", "30-BIT COLOR" is transmitted using a higher clock frequency. The clock frequency may cause noise if a poor-quality or an excessively long cable is connected. In such a case, the noise may be removed by setting the color to "24-BIT COLOR".

This setting will be valid only if "BUILT-IN EDID" is selected for EDID in **"9.12.1 EDID selection"** and "HDMI" is selected for **"9.12.4 HDMI/DVI"**.

Press the "MENU/ENTER" button to apply the setting.

If "ANALOG" is selected for **"9.6.1 DVI input connector signal"**, "NOT AVAILABLE NOW" will appear on the front display.

### 9.12.7 LPCM audio

---

Menu	Top→EDID SETTINGS→Linear PCM
Setting for	ALL, IN1 to IN5, IN6 (Digital), IN7 (Digital)
Setting value	<ul style="list-style-type: none"> <li>• 32kHz      • 44.1kHz      • 48kHz [Default]      • 88.2kHz</li> <li>• 96kHz      • 176.4 kHz      • 192kHz</li> </ul>

You can set the maximum LPCM sampling frequency that is output from the source device.

This setting will be valid only if "BUILT-IN EDID" is selected for EDID in **"9.12.1 EDID selection"** and "HDMI" is selected for **"9.12.4 HDMI/DVI"**.

Press the "MENU/ENTER" button to apply the setting.

If "ANALOG" is selected for **"9.6.1 DVI input connector signal"**, "NOT AVAILABLE NOW" will appear on the front display.

### 9.12.8 AAC audio

---

Menu	Top→EDID SETTINGS→AAC			
Setting for	ALL, IN1 to IN5, IN6 (Digital), IN7 (Digital)			
Setting value	<ul style="list-style-type: none"> <li>• OFF [Default]    • 32kHz    • 44.1kHz    • 48kHz</li> <li>• 88.2kHz    • 96kHz</li> </ul>			

You can set the maximum AAC audio sampling frequency that is output from the source device.

This setting will be valid only if "BUILT-IN EDID" is selected for EDID in **"9.12.1 EDID selection"** and "HDMI" is selected for **"9.12.4 HDMI/DVI"**.

Press the "MENU/ENTER" button to apply the setting.

If "ANALOG" is selected for **"9.6.1 DVI input connector signal"**, "NOT AVAILABLE NOW" will appear on the front display.

### 9.12.9 Dolby Digital audio

---

Menu	Top→EDID SETTINGS→Dolby Digital			
Setting for	ALL, IN1 to IN5, IN6 (Digital), IN7 (Digital)			
Setting value	<ul style="list-style-type: none"> <li>• OFF [Default]    • 32kHz    • 44.1kHz    • 48kHz</li> </ul>			

You can set the maximum Dolby Digital audio sampling frequency that is output from the source device.

This setting will be valid only if "BUILT-IN EDID" is selected for EDID in **"9.12.1 EDID selection"** and "HDMI" is selected for **"9.12.4 HDMI/DVI"**.

Press the "MENU/ENTER" button to apply the setting.

If "ANALOG" is selected for **"9.6.1 DVI input connector signal"**, "NOT AVAILABLE NOW" will appear on the front display.

### 9.12.10 Dolby Digital Plus audio

---

Menu	Top→EDID SETTINGS→Dolby Digital Plus
Setting for	ALL, IN1 to IN5, IN6 (Digital), IN7 (Digital)
Setting value	• OFF [Default]    • 32kHz    • 44.1kHz    • 48kHz

You can set the maximum Dolby Digital Plus audio sampling frequency that is output from the source device.

This setting will be valid only if "BUILT-IN EDID" is selected for EDID in "9.12.1 EDID selection" and "HDMI" is selected for "9.12.4 HDMI/DVI".

Press the "MENU/ENTER" button to apply the setting.

If "ANALOG" is selected for "9.6.1 DVI input connector signal", "NOT AVAILABLE NOW" will appear on the front display.

### 9.12.11 Dolby TrueHD audio

---

Menu	Top→EDID SETTINGS→Dolby TrueHD
Setting for	ALL, IN1 to IN5, IN6 (Digital), IN7 (Digital)
Setting value	• OFF [Default]    • 44.1kHz    • 48kHz    • 88.2kHz • 96kHz    • 176.4kHz    • 192kHz

You can set the maximum Dolby TrueHD audio sampling frequency that is output from the source device.

This setting will be valid only if "BUILT-IN EDID" is selected for EDID in "9.12.1 EDID selection" and "HDMI" is selected for "9.12.4 HDMI/DVI".

Press the "MENU/ENTER" button to apply the setting.

If "ANALOG" is selected for "9.6.1 DVI input connector signal", "NOT AVAILABLE NOW" will appear on the front display.

### 9.12.12 DTS audio

---

Menu	Top→EDID SETTINGS→DTS
Setting for	ALL, IN1 to IN5, IN6 (Digital), IN7 (Digital)
Setting value	<ul style="list-style-type: none"> <li>• OFF [Default]</li> <li>• 32kHz</li> <li>• 44.1kHz</li> <li>• 48kHz</li> <li>• 96kHz</li> </ul>

You can set the maximum DTS audio sampling frequency that is output from the source device.

This setting will be valid only if "BUILT-IN EDID" is selected for EDID in **"9.12.1 EDID selection"** and "HDMI" is selected for **"9.12.4 HDMI/DVI"**.

Press the "MENU/ENTER" button to apply the setting.

If "ANALOG" is selected for **"9.6.1 DVI input connector signal"**, "NOT AVAILABLE NOW" will appear on the front display.

### 9.12.13 DTS-HD audio

---

Menu	Top→EDID SETTINGS→DTS-HD
Setting for	ALL, IN1 to IN5, IN6 (Digital), IN7 (Digital)
Setting value	<ul style="list-style-type: none"> <li>• OFF [Default]</li> <li>• 44.1kHz</li> <li>• 48kHz</li> <li>• 88.2kHz</li> <li>• 96kHz</li> <li>• 176.4kHz</li> <li>• 192kHz</li> </ul>

You can set the maximum DTS-HD audio sampling frequency that is output from the source device.

This setting will be valid only if "BUILT-IN EDID" is selected for EDID in **"9.12.1 EDID selection"** and "HDMI" is selected for **"9.12.4 HDMI/DVI"**.

Press the "MENU/ENTER" button to apply the setting.

If "ANALOG" is selected for **"9.6.1 DVI input connector signal"**, "NOT AVAILABLE NOW" will appear on the front display.

### 9.12.14 Speaker configuration

Menu Top→EDID SETTINGS→SPEAKER CONFIGURATION

Setting for ALL, IN1 to IN5, IN6 (Digital), IN7 (Digital)

Setting value

[Table 9.21] Speaker configuration

Setting item	MODE (Setting mode)	NUMBER (Number of speakers)	Setting value for speaker configuration	
Setting value	AUTO [Default]	1 to 8 [Default] 2	【See: [Table 9.22] Default speaker configuration】	
	MANUAL	2	FL/FR	ON [Default], OFF
		1	LFE	ON, OFF [Default]
		1	FC	ON, OFF [Default]
		2	RL/RR	ON, OFF [Default]
		1	RC	ON, OFF [Default]
		2	FLC/FRC	ON, OFF [Default]
		2	RLC/RRC	ON, OFF [Default]
		2	FLW/FRW	ON, OFF [Default]
		2	FLH/FRH	ON, OFF [Default]
		1	TC	ON, OFF [Default]
		1	FCH	ON, OFF [Default]
		The number of speakers is calculated based on speaker configuration. UP to eight speakers can be used.		

You can set the speaker configuration for multi-channel audio.

If you select "AUTO" for the setting mode and set the number of speakers, the speaker configuration will be set automatically.

【See: [Table 9.22] Default speaker configuration】

To change the default configuration, set the mode to "MANUAL" and set each speaker to ON/OFF individually. If the number of speakers exceeds the available value, the "DATA INVALID" message is displayed and the settings will not be applied.

This setting will be valid only if "BUILT-IN EDID" is selected for EDID in "9.12.1 EDID selection" and "HDMI" is selected for "9.12.4 HDMI/DVI".

Press the "MENU/ENTER" button to apply the setting.

If "ANALOG" is selected for "9.6.1 DVI input connector signal", "NOT AVAILABLE NOW" will appear on the front display.

[Table 9.22] Default speaker configuration

Number of speakers	FL/FR	LFE	FC	RL/RR	RC	FLC/FRC	RLC/RRC	FLW/FRW	FLH/FRH	TC	FCH
1	OFF	OFF	ON	OFF	OFF	OFF	OFF	OFF	OFF	OFF	OFF
2 [Default]	ON	OFF	OFF	OFF	OFF	OFF	OFF	OFF	OFF	OFF	OFF
3	ON	ON	OFF	OFF	OFF	OFF	OFF	OFF	OFF	OFF	OFF
4	ON	ON	ON	OFF	OFF	OFF	OFF	OFF	OFF	OFF	OFF
5	ON	ON	OFF	ON	OFF	OFF	OFF	OFF	OFF	OFF	OFF
6	ON	ON	ON	ON	OFF	OFF	OFF	OFF	OFF	OFF	OFF
7	ON	ON	ON	ON	ON	OFF	OFF	OFF	OFF	OFF	OFF
8	ON	ON	ON	ON	OFF	OFF	ON	OFF	OFF	OFF	OFF

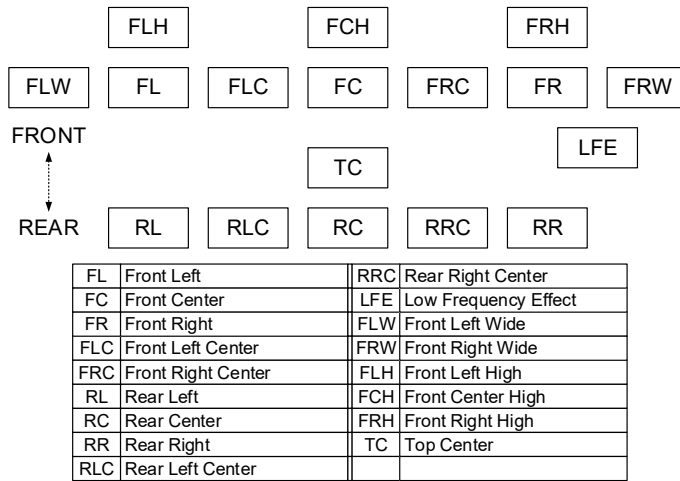

[Fig. 9.30] Speaker configuration

## 9.13 RS-232C

### 9.13.1 RS-232C communication

Menu Top→RS-232C SETTINGS→PARAMETERS

Setting for ALL, RS, HDBT OUT1B, HDBT OUT2B

Setting value

[Table 9.23] RS-232C communication

Parameter	Setting value	Default
Baud rate [bps]	4800, 9600, 14400, 19200, 38400, 57600, 115200	9600
Data bit length [bit]	8, 7	8
Parity check	NONE, EVEN, ODD	NONE
Stop bit [bit]	1, 2	1

You can set the RS-232C communication.

Press the "MENU/ENTER" button to apply the setting.

### 9.13.2 RS-232C operation mode

Menu Top→RS-232C SETTINGS→COMMUNICATION MODE

Setting for ALL, RS, HDBT OUT1B, HDBT OUT2B

Setting value

[Table 9.24] RS-232C operation mode

Connector	Setting value	Default
ALL	RECEIVER, TRANSMITTER	---
RS	RECEIVER, TRANSMITTER	RECEIVER
HDBT OUT1B	RECEIVER, TRANSMITTER	TRANSMITTER
HDBT OUT2B	RECEIVER, TRANSMITTER	TRANSMITTER

You can set the operation mode of the MSD-S's RS-232C port to either "RECEIVER" mode, enabling the MSD-S to be controlled externally via RS-232C, or "TRANSMITTER" mode, enabling the MSD-S to control peripheral devices via RS-232C.

Press the "MENU/ENTER" button to apply the setting.

## 9.14 LAN

---

### 9.14.1 IP address

---

Menu  Top→LAN SETTINGS→IP ADDRESS  
Setting value  192.168.1.199 [Default]

You can set the IP address.

Press the "MENU/ENTER" button to apply the setting.

### 9.14.2 Subnet mask

---

Menu  Top→LAN SETTINGS→SUBNET MASK  
Setting value  255.255.255.0 [Default]

You can set the subnet mask.

Press the "MENU/ENTER" button to apply the setting.

### 9.14.3 Gateway address

---

Menu  Top→LAN SETTINGS→GATEWAY  
Setting value  192.168.1.200 [Default]

You can set the gateway address.

Press the "MENU/ENTER" button to apply the setting.

### 9.14.4 MAC address

---

Menu  Top→LAN SETTINGS→MAC ADDRESS

You can display the MSD-S's MAC address.

### 9.14.5 TCP port number

---

Menu  Top→LAN SETTINGS→PORT NUMBER

Setting for  CONNECTION 1 to CONNECTION 8

Setting value

[Table 9.25] TCP port number

For	Setting value
Communication command control	23, 1100, 6000 to 6999
WEB browser control	80, 5000 to 5999

[Default] Connection 1 to 3 = 1100; Connection 4 to 6 = 23; Connection 7, 8 = 80

You can set the TCP port number to control the MSD-S externally.

This setting will be valid if "RECEIVER" is selected for "9.14.6 LAN operation mode".

Each connection will be divided into connections for communication command control and WEB browser depending on the set port numbers.

Press the "MENU/ENTER" button to apply the setting.

### 9.14.6 LAN operation mode

Menu Top→LAN SETTINGS→COMMUNICATION MODE  
 Setting for CONNECTION 1 to CONNECTION 8  
 Setting value

[Table 9.26] LAN operation mode

Items	Setting value	
	Receiver mode	Transmitter mode
Operation mode	RECEIVER [Default]	TRANSMITTER
Destination IP address	N/A	0.0.0.0 to 255.255.255.255 [Default] 192.168.1.198
PJLink protocol connection	N/A	ON : Use OFF : Not use [Default]
Destination connection number*1	N/A	1 to 65535 [Default] 1100
PJLink protocol password*2	N/A	20, 30 to 39, 41 to 5A, 61 to 7A in ASCII code (in hex) [Default] 20 (space)

\*1For PJLink protocol connections, the target port number is fixed at "4352".

\*2For PJLink protocol connections, the maximum permissible number of characters is 32.

If you do not want password authentication, you do not have set a password.

You can set the LAN operation mode to either "RECEIVER" mode that controls the MSD-S externally or "TRANSMITTER" mode that controls peripheral devices from the MSD-S.

If you select "TRANSMITTER" mode, you need to set the parameters to support the connected device that will be controlled.

Press the "MENU/ENTER" button to apply the setting.

### 9.14.7 HDBaseT LAN

Menu Top→LAN SETTINGS→HDBT COMMUNICATION  
 Setting for HDBT OUT1B, HDBT OUT2B  
 Setting value ON [Default], OFF

You can enable/disable the LAN capabilities of each HDBaseT output connector.

#### ■ LAN loop problem

The MSD-S includes switching hub function. If the MSD-S communicates with a product having a switching hub over LAN, the network may be down due to loop problem.

In case the loop problem occurs, set "7.4.2 LAN communication" to "OFF".

## 9.15 Control commands

You can control external devices (for example, turning ON/OFF projectors) via RS-232C, LAN, or CEC. You can register up to 32 commands (CMD 1 to CMD32) in the MSD-S. Registered control commands will be associated with 45 execution conditions such as "Function" buttons or "FN" buttons or switching video or audio.

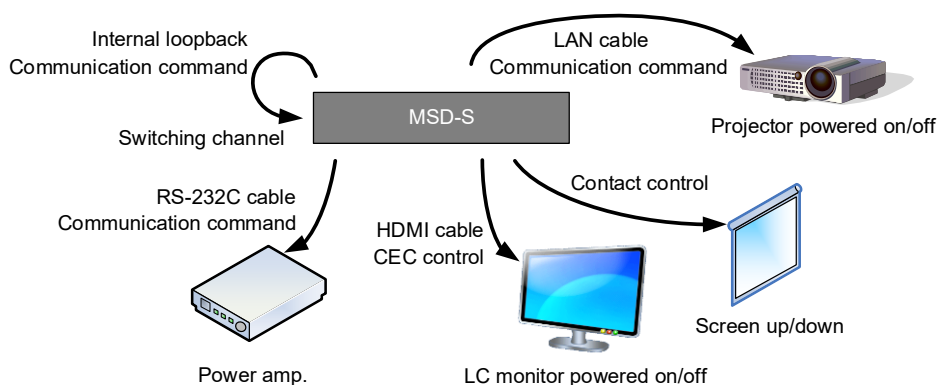

[Fig. 9.31] Control command example

### ■ Control command via RS-232C/LAN communication

Control commands can be sent from MSD-S's RS-232C connector, LAN connector, or HDBaseT output connector.

Before executing control command, set the operation mode of the connector to "TRANSMITTER".

【See: 9.13.2 RS-232C operation mode】

【See: 9.14.6 LAN operation mode】

### ■ Screen display during control command execution

When a control command is executed, "MEMO" text registered for a control command is displayed (1). If the reply command is received, the "MEMO" text registered for the reply command is also displayed (2) for one second.

The received data is displayed (3) for two seconds (when the control command that is used for displaying the received data is executed)

Examples:

(1) "SCREEN UP" is registered in MEMO and the control command is executed.

(2) A reply command, "SCREEN OK", is displayed.

(3) "%1LAMP=1000 1 ↵" is received.

(4) Reply command could not be received and retry over occurs.

(1) Only control command

```
SEND:SCREEN UP
```

(2) Control command (upper)  
Reply command (lower)

```
SEND:SCREEN UP
RECV:SCREEN OK
```

(3) Received data is displayed.

```
SEND:PROJECTOR LAMP
RECV:%1LAMP=1000 1↵
```

(4) Reply command cannot be  
received and a retry error occurs.

```
SEND:SCREEN UP
RETRY OVER ERROR
```

[Fig. 9.32] Front panel display

If you configure multiple control commands, or if you display data received from multiple com ports, the display time may be shortened by one to two seconds while control commands are being successively executed. If the received data does not fit in the full screen, the displayed data is scrolled.

### 9.15.1 Registering/Editing control command

Menu Top→CONTROL COMMAND→COMMAND REGISTER/EDIT

Setting for CMD 1 to CMD32

Setting value [Table 9.27] Setting control command

You can register and edit up to 32 control commands.

Press the "MENU/ENTER" button to apply the setting.

[Table 9.27] Setting control command

[1/2]

Setting item	COM	CC	CEC	Description	Range
PORT	yes	yes	yes	Select "COM", "CC" or "CEC".	COM : Communication command [Default] CC : Contact closure CEC : HDMI CEC control
COM SIZE	yes	no	no	Set the number of bytes to be sent starting with the first byte.	0BYTE to 30BYTE [Default] 0BYTE
DELAY	yes	yes	yes	Set the waiting time to issue control commands. Use this item for devices such as projectors that requires time to cool down after powering off.	0ms to 999s999ms [Default] 0ms
Communication port	yes	no	no	Set the following communication ports to "OFF" (not sending communication commands) or "ON" (sending communication commands). Those ports can be set separately, and communication commands can be sent to multiple communication ports at the same time. - RS : RS-232C <sup>*1</sup> - OUT1B RS : HDBT OUT1B RS-232C <sup>*1</sup> - OUT2B RS : HDBT OUT2B RS-232C <sup>*1</sup> - LOOP BACK : Internal loop back - LAN1 to LAN8 : LAN connection 1 to 8 <sup>*2</sup>	OFF : Not sending reply command [Default] ON : Sending reply command
COMMAND INPUT MODE	yes	no	no	Set the input mode of send command data. Select "ASCII" if "DATA" of "COMMAND" consists of only 0A, 0D, and 20 to 7D of ASCII codes. Select "HEX" if "DATA" of "COMMAND" includes other codes.	ASCII [Default] HEX
Send command data	yes	no	no	Set the command from the first byte according to the number of bytes set in "COM SIZE" (up to 30 bytes).	0A, 0D, 20 to 7D in ASCII, 00 to FF in hex [Default] 20 (space)

[2/2]

Setting item	COM	CC	CEC	Description	Range
RECV DISPLAY	yes	no	no	Set whether received data is displayed or not.	OFF [Default] ASCII HEX
DELIMITER <sup>3</sup>	yes	no	no	Set the delimiter to be sent at the end of the received data. "NONE": Delimiter is not checked and all received data within the set timeout will be valid. Value other than "NONE": Delimiter is checked and data received before delimiter will be valid.	NONE : Not checking delimiter [Default] 00 to FF (Hex)
RCV CHECK <sup>4</sup>	yes	no	no	Set whether reply command that may be returned is checked or not.	CHECK NOT CHECK [Default]
TIME OUT <sup>5 6</sup>	yes	no	no	Set the timeout delay for reply command to a sent command.	0ms to 99s999ms [Default] 0ms
RETRY <sup>5 6</sup>	yes	no	no	Set the number of retries to resend the same command again if no valid response is received.	0 to 99 (times) [Default] 0
INTERVAL <sup>5 6</sup>	yes	no	no	Set the retry interval to resend the command.	0ms to 99s999ms [Default] 0ms
ERROR <sup>5 6</sup>	yes	no	no	Set whether the next command is to be executed or not if no valid response is replied, even after completing retry for the set number of retries.	STOP [Default] EXEC : Continue
Contact closure control	no	yes	no	Set the contact closure control. If you select "toggle operation", it can invert the condition of contact (open/close).	- : Not controlling contact closure [Default] OFF : Opening contact ON : Closing contact TGL : Toggle
Pulse width	no	yes	no	Set the time of returning its original condition when you control the contact closure.	NONE : Eternity [Default] 100ms to 9990ms (by 10ms)
CEC control <sup>7</sup>	no	no	yes	Set the CEC control for each HDMI and HDBaseT output.	- : Not controlling CEC [Default] POWER OFF POWER ON
Process for CEC error	no	no	yes	Set whether the next command is executed or not if no response is replied from the sink device that is controlled with CEC.	STOP [Default] EXEC : Continue
MEMO	yes	yes	yes	Register a note containing up to 14 characters. The registered note is displayed when the control command is executed.	20 to 7D in ASCII codes except for 2C (,) [Default] 20 (space)

- \*1 If you set "RS: RS-232C", "OUT1B RS: HDBT OUT1B RS-232C", or "OUT2B RS: HDBT OUT2B RS-232C" to "ON", set RS-232C operation mode to "TRANSMITTER".
- \*2 If you set any LAN connections for "LAN1" to "LAN8" to "ON", set LAN operation mode to "TRANSMITTER".
- \*3 If you set "RECV DISPLAY" to "OFF", you cannot set this item.
- \*4 If you set "RECV DISPLAY" to "ASCII" or "HEX", you cannot set this item.
- \*5 If you set only "LOOP BACK" for communication ports to "ON", you do not need to set this item.
- \*6 If you set all "RCV CHECK" to "NOT CHECK", you do not need to set this item.
- \*7 CEC: only power ON/OFF of the sink device can be controlled.

【See: 9.13.2 RS-232C operation mode】

【See: 9.14.6 LAN operation mode】

#### ■ Setting loop back function

The MSD-S sends a communication command back to the MSD-S itself using the loop back function. It replies "OK" if processed normally while replying "NG" if parameter or command is incorrect. To check the reply command, set reply command 31 and 32 to "CHECK".

#### ■ Setting PJLink

The MSD-S supports PJLink Class 1, which is a standard protocol to control projectors. To use PJLink, select the LAN connector for COM port so that you can select PJLink command when entering the send command data.

【See: 9.14.6 LAN operation mode】

【See: [Table 9.28] PJLink command (class1)】

**[Table 9.28] PJLink command (class1)**

No.	Command										Description
1	%	1	P	O	W	R	(SP)	0	(CR)		Power off (Standby)
2	%	1	P	O	W	R	(SP)	1	(CR)		Power on (Lamp on)
3	%	1	P	O	W	R	(SP)	?	(CR)		Get power status
4	%	1	I	N	P	T	(SP)	1	*	(CR)	Switch input to RGB
5	%	1	I	N	P	T	(SP)	2	*	(CR)	Switch input to VIDEO
6	%	1	I	N	P	T	(SP)	3	*	(CR)	Switch input to DIGITAL
7	%	1	I	N	P	T	(SP)	4	*	(CR)	Switch input to STORAGE
8	%	1	I	N	P	T	(SP)	5	*	(CR)	Switch input to NETWORK
9	%	1	I	N	P	T	(SP)	?	(CR)		Get input selection settings
10	%	1	A	V	M	T	(SP)	1	0	(CR)	Switch off video mute
11	%	1	A	V	M	T	(SP)	1	1	(CR)	Switch on video mute
12	%	1	A	V	M	T	(SP)	2	0	(CR)	Switch off audio mute
13	%	1	A	V	M	T	(SP)	2	1	(CR)	Switch on audio mute
14	%	1	A	V	M	T	(SP)	3	0	(CR)	Video + audio mute off
15	%	1	A	V	M	T	(SP)	3	1	(CR)	Video + audio mute on
16	%	1	A	V	M	T	(SP)	?	(CR)		Get mute settings
17	%	1	E	R	S	T	(SP)	?	(CR)		Get error status
18	%	1	L	A	M	P	(SP)	?	(CR)		Get time and status of lamp
19	%	1	I	N	S	T	(SP)	?	(CR)		Get list of switching input
20	%	1	N	A	M	E	(SP)	?	(CR)		Get projector name
21	%	1	I	N	F	1	(SP)	?	(CR)		Get manufacture name
22	%	1	I	N	F	2	(SP)	?	(CR)		Get product name
23	%	1	I	N	F	O	(SP)	?	(CR)		Get other information (optional of manufacturer)

(SP): space, (CR): delimiter

\* You can specify the input number from 1 to 9, but types and the number of selectable input connectors differ depending on the projector. "1" is displayed by default.

Reply command structure for PJLink commands:

The first 6 bites: the sent command data without change; the 7th bite: "="; after the 8th bite: processing result  
For example, if a command, "%1POWR 1CR", is processed normally, the reply command, "%1POWR=OK CR" will be replied.

PJLink specifications regulate that projectors are required to reply the reply commands within two seconds after receiving the PJLink command. However, some projectors have different specifications. Check the manual of your projector and apply the response time indicated in the manual if there is one listed.

**[Table 9.29] Reply commands to PJLink command (class1)**

No.	Command										Description
1	%	1	x	x	x	x	=	O	K	(CR)	Terminated normally
2	%	1	x	x	x	x	=	E	R	R 1 (CR)	Mistake in command itself (Undefined command)
3	%	1	x	x	x	x	=	E	R	R 2 (CR)	Invalid parameter
4	%	1	x	x	x	x	=	E	R	R 3 (CR)	Currently not acceptable
5	%	1	x	x	x	x	=	E	R	R 4 (CR)	Malfunction of projector

**[Table 9.30] Individual reply command of status acquisition commands**

No.	Command										Description			
Reply command to power status commands														
1	%	1	P	O	W	R	=	0	(CR)		Standby			
2	%	1	P	O	W	R	=	1	(CR)		Power ON			
3	%	1	P	O	W	R	=	2	(CR)		Cooling			
4	%	1	P	O	W	R	=	3	(CR)		Warming up			
Reply command to input status commands														
1	%	1	I	N	P	T	=	1	*1	(CR)	RGB selected			
2	%	1	I	N	P	T	=	2	*1	(CR)	VIDEO selected			
3	%	1	I	N	P	T	=	3	*1	(CR)	DIGITAL selected			
4	%	1	I	N	P	T	=	4	*1	(CR)	STORAGE selected			
5	%	1	I	N	P	T	=	5	*1	(CR)	NETWORK selected			
Get mute settings														
1	%	1	A	V	M	T	=	3	0	(CR)	Video + audio Mute OFF			
2	%	1	A	V	M	T	=	1	1	(CR)	Video Mute ON			
3	%	1	A	V	M	T	=	2	1	(CR)	Audio Mute ON			
4	%	1	A	V	M	T	=	3	1	(CR)	Video + audio mute ON			
Get error status														
1	%	1	E	R	S	T	=	*2	*3	*4	*5	*6	*7	(CR)
Get time and status of lamp														
1	%	1	L	A	M	P	=	*8	(SP)	*9	(CR)			
Get list of input switching														
1	%	1	I	N	S	T	=	*10	(CR)					
Get projector name														
1	%	1	N	A	M	E	=	*11	(CR)					
Get manufacturer name														
1	%	1	I	N	F	1	=	*12	(CR)					
Get product name														
1	%	1	I	N	F	2	=	*12	(CR)					
Get other information (optional)														
1	%	1	I	N	F	O	=	*12	(CR)					

\*1 Input number, which is any of "1" to "9", but types and the numbers of selectable input connectors differ depending on connected projectors.

\*2 Fan error                    \*3 Lamp error

\*4 Temperature error       \*5 Cover open error

\*6 Filter error               \*7 Other errors

For \*2 to \*7: 0: Error not detected or no detect error function, 1: Warning, 2: Error

\*8 Accumulated time of lamp, which is any of 0 to 99999.

(For projectors that do not count the accumulated time, the value is 0 at all times.)

\*9 Whether the lamp illuminates or not (0 or 1).

0: Not illuminated, 1: Illuminated

For devices containing multiple lamps, accumulated time and lightning state for each device are replied in sequence. For example, if a device containing three lamps, the following command is replied:

"%1LAMP=accumulated time 1(SP) lightning state 1(SP) accumulated time 2(SP) lightning state 2(SP) accumulated time 3(SP) lightning state 3 CR"

\*10 Source number, which is input switchable. Any of 11 to 59 (Meaning is the same as that of "%INPT" command). For devices containing multiple inputs, multiple statuses separated with a (SP) are sent.

For example, for a device having two inputs, "%1INST= source number1 (SP) source number2 CR" is sent.

\*11 20 to FF in hex: up to 64 characters

\*12 20 to 7F in hex: up to 32 characters

## 9.15.2 Registering/Editing reply command

Menu	Top→CONTROL COMMAND→REPLY REGISTER/EDIT
Setting for	REPLY 1 to REPLY32
Setting value	[Table 9.31] Setting reply command

You can register and edit up to 32 reply commands.  
Press the "MENU/ENTER" button to apply the setting.

[Table 9.31] Setting reply command

Item	Description	Range
SIZE	Set the number of bytes from the first byte to be compared.	0BYTE to 30BYTE [Default] 0BYTE
PROCESS	Select "STOP" (to stop the next operation), "EXEC" (to execute it), or "RETRY" (to send the command again) for when received data and reply command data match.	EXEC [Default] RETRY: Resend reply commands STOP
PJLink	Select whether PJLink commands are set or not for when input reply command data is input.	OFF [Default] ON
COMMAND INPUT MODE	Select the input mode of reply command data. "ASCII": For data consisting of only 0A, 0D, 20 to 7D (text) "HEX": For data including other codes	ASCII [Default] HEX
DATA	Set the command to be compared with the received data from the first byte to the byte count set in "SIZE". If using alphabets (A to Z, a to z), make sure to distinguish capital and lower case letters. (Up to 30 bytes)	0A, 0D, and 20 to 7D of ASCII code or 00 to FF (Hex) [Default] 20 (Space)
MASK	Each bit of the received data is ANDed to each bit of mask data, and the result will be compared with the reply command data. (Use this item to determine the state using the received data bit. Settable if "COMMAND INPUT MODE" is set to "HEX"; if "ASCII" is selected, "FF" is set automatically.)	00 to FF (Hex) [Default] All: "FF"
MEMO	Register a note containing up to 14 characters. When reply command is received, the registered note is displayed.	20 to 7D of ASCII code except for 2C (,) [Default] All: Space

Default values in the table above do not apply to reply commands 31 and 32.

### ■ Setting loop back function

If the MSD-S sends a communication command back to the MSD-S itself using the loop back function, the MSD-S replies "OK" if processed normally while it replies "NG" if parameter or communication command is incorrect. (This differs from reply commands to communication commands received externally; not loop back.) Since "OK" and "NG" are registered to reply commands 31 and 32 by factory default, respectively, do not edit or delete those commands if you use the loop back function and are checking reply commands.

**[Table 9.32] Default value of reply command**

Number	SIZE	PROCESS	DATA	MASK	MEMO
1	0 byte	EXEC	All: 00	All: FF	All: 20 (space)
2	0 byte	EXEC	All: 00	All: FF	All: 20 (space)
:	:	:	:	:	:
30	0 byte	EXEC	All: 00	All: FF	All: 20 (space)
31	2 bytes	EXEC	OK	All: FF	OK
32	2 bytes	STOP	NG	All: FF	NG

### ■ Setting PJLink

The MSD-S supports PJLink Class 1, which is a standard protocol to control projectors.

If setting "PJLink" to "ON", PJLink command can be selected when "Reply command data" is input.

【See: [Table 9.28] PJLink command (class1)】

### ■ Mask data

Each bit of the received data is ANDed to each bit of mask data, and the result will be compared with the reply command data. Since "FF" is set by factory default, you do not need to change the mask data normally.

This feature is used to interpret the status of specific bits in received data and provides a reply that can be used to confirm or alter settings.

[If ASCII codes (text) are replied from an external device]

Since the received data and "Reply command data" are compared without any changes, set "MASK" to "FF".

(If you set "COMMAND INPUT MODE" of reply command to "ASCII", it is automatically set to "FF".)

For example, if "0" of ASCII codes ("30" in hex) is replied:

	Binary		Binary	Hexadecimal
(Received data)	00110000	& (MASK)	11111111	=30
(Reply command data)	00110000			=30 matched

```
DATA1: 30 00 00 00 00
MASK1: FF FF FF FF FF
```

[If status is determined using bits of the received data]

Set only bits that determine the Mask data to "1" and set other bits to "0".

For example, if determining status using the second bit from the left:

	Binary		Binary	Hexadecimal
(Received data)	11111111	& (MASK)	01000000	=40
(Reply command data)	01000000			=40 matched

	Binary		Binary	Hexadecimal
(Received data)	10111111	& (MASK)	01000000	=00
(Reply command data)	01000000			=40 not matched

```
DATA1: 40 00 00 00 00
MASK1: 40 FF FF FF FF
```

### 9.15.3 Command link

Menu	Top→CONTROL COMMAND→COMMAND LINK		
Setting for	[Table 9.33] Control command execution condition		
Setting value	TOGGLE	: OFF	[Default], ON (only for "F" and "FN" buttons)
	STARTUP	: AUTO	[Default], A, B (only for "F" and "FN" buttons)
	1st to 10th	: OFF	[Default], CMD 1 to CMD32

The MSD-S has up to 45 command execution conditions. If these execution conditions are met, control commands which are associated beforehand will be executed. One execution condition can be associated to up to 10 commands. If multiple commands are associated, commands are executed in order of registration. If the same command is associated multiple times, it is repeatedly executed.

"F" and "FN" buttons button can be toggled.

Set "TOGGLE" to "ON" to enable PLANE-A and PLANE-B. Up to 10 commands can be set for each plane.

"STARTUP": Setting the start-up plane of toggle button. If you select "AUTO", the condition at the time of power OFF will be maintained.

For "F1" to "F4" and FN buttons, the selected plane for "START-UP" is executed at the time of powered ON if Sending control command automatically function is set to "ON".

Press the "MENU/ENTER" button to apply the setting.

【See: 9.19.2 Sending control command automatically】

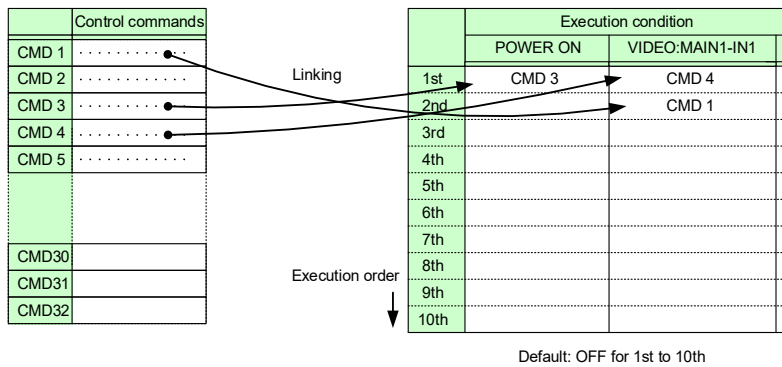

**[Fig. 9.33] Command link**

**[Table 9.33] Control command execution condition**

Execution condition	Toggle	Function
F1 to F9	Yes	F button
FN1, FN2	Yes	FN button
POWER ON	No	Standby control
STANDBY		
VIDEO:MAIN1-IN1 to VIDEO:MAIN1-IN7, VIDEO:MAIN1-OFF	No	Selecting video input channel of OUT1 (MAIN1)
AUDIO:MAIN1-IN1 to AUDIO:MAIN1-IN7, AUDIO:MAIN1-OFF	No	Selecting audio input channel of OUT1 (MAIN1)
VIDEO:MAIN2-IN1 to VIDEO:MAIN2-IN7, VIDEO:MAIN2-OFF	No	Selecting video input channel of OUT2 (MAIN2)
AUDIO:MAIN2-IN1 to AUDIO:MAIN2-IN7, AUDIO:MAIN2-OFF	No	Selecting audio input channel of OUT2 (MAIN2)

### 9.15.4 Command execution

---

**Menu** Top→CONTROL COMMAND→EXECUTE CTRL COMMAND  
**Setting value** CMD 1 to CMD 32, F1 to F9, FN1, FN2

You can execute registered control commands (CMD 1 to CMD 32) and assigned control commands (F1 to F9, FN1, and FN2).

Only executable control commands are displayed.

Press the "MENU/ENTER" button to apply the setting.

Registered control commands can be executed from communication commands or WEB browser.

Commands assigned to F1 to F4, FN1, and FN2 can also be executed from front buttons.

### 9.15.5 Initializing registered command and link

---

**Menu** Top→CONTROL COMMAND→INITIALIZATION  
**Setting value** CMD 1 to CMD32 : Control command  
REPLY 1 to REPLY32 : Reply command  
F1-PLANE A to AUDIO:MAIN2-OFF : Control command association

You can initialize the following commands and associations:

- 9.15.1 Registering/Editing control command
- 9.15.2 Registering/Editing reply command
- 9.15.3 Command link

Press the "MENU/ENTER" button to initialize commands and associations above.

Note that settings cannot be restored once initialized.

### 9.15.6 Invalid duration at control command execution

Menu Top→CONTROL COMMAND→INVALID DURATION  
 Setting value 0s000ms to 999s999ms [Default] 0s000ms

You can set the wait time that starts at control command execution and must elapse prior to accepting user input to resend the command. Right after control command execution is completed, the next command can be executed. Use this menu to prevent repeated execution caused by pressing the control command execution button twice.

During invalid operation time, all button operations are disabled.

The longer time either of control command execution time or the time set in this menu will be applied as the invalid operation time.

### 9.15.7 Illuminating function buttons

Menu Top→CONTROL COMMAND→ILLUMINATE FN. BUTTON  
 Setting for F1 to F9, FN1, FN2  
 Setting value

You can set the illuminating function for function buttons on the WEB browser and on the front panel.

**[Table 9.34] Illuminating function buttons**

Illuminating condition	If you register a command only for one plane	If you register commands for both two planes
REGISTERED	Illuminates green if a control command is registered.	Illuminates green if PLANE A will be executed at the next press; blinks green if PLANE B will be executed at the next press.
EXECUTION	Illuminates while a control command is being executed.*1	Illuminates green if PLANE A will be executed at the next press; turned off if PLANE B will be executed at the next press.

[Default] F1 to F9 : REGISTRED  
 FN1, FN2 : EXECUTION

\*1 If execution duration is 500 ms. or shorter, the button LED illuminates for 500 ms.

You can set function buttons to be blinking during control command execution.

**[See: 9.15.8 Function button blinking duration]**

### 9.15.8 Function button blinking duration

Menu	Top→CONTROL COMMAND→BLINKING DURATION
Setting for	F1 to F4, FN1, FN2
Setting value	EXECUTION, OFF, 1sec. to 1000sec. [Default] F1 to F4 : OFF FN1, FN2 : EXECUTION

\*EXECUTION: Blinks while a control command is being executed

While control commands are being executed, these buttons blink regardless of this menu's setting.

### 9.15.9 Assigning function

Menu	Top→CONTROL COMMAND→FUNCTION ASSIGN
Setting for	F1 to F4, FN1, FN2
Setting value	

**[Table 9.35] Assigning function**

Setting value	Function	Color
COMMAND	Executes control commands [Default]	Green
OUT1 PinP PATTERN	Selects layout pattern of OUT1 In order of patterns 1 to 5 and OFF	Green
OUT2 PinP PATTERN	Selects layout pattern of OUT2 In order of patterns 1 to 5 and OFF	Green
PinP WINDOW	Selects input windows. When illuminates: For main window input When turns off: For PinP window input	Green
CROSSPOINT No.1 to CROSSPOINT No.9	Loads crosspoint	Red
PRESET MEMORY No.1 to PRESET MEMORY No.8	Loads preset memory	Amber

Once commands are assigned to function buttons, these commands can be executed from front buttons.

【See: 9.15 Control commands】

【See: 9.16.6 Layout pattern】

【See: 9.20.1 PinP window setting】

【See: 9.16.1 Recalling crosspoint】

【See: 9.16.4 Recalling preset memory】

## 9.16 Preset memory

All settings, including I/O channel settings of video and audio and image position are saved to preset memory:  
I/O channel settings of video and audio are saved to the MSD-S memory as crosspoint.

### 9.16.1 Recalling crosspoint

Menu Top→USER PRESET→RECALL CROSSPOINT  
Setting value No.1 to No.9

You can recall the I/O channel settings and layout patterns saved in the crosspoint memory.

Press the "MENU/ENTER" button to apply the setting.

【See: 9.16.2 Saving crosspoint】

### 9.16.2 Saving crosspoint

Menu Top→USER PRESET→STORE CROSSPOINT  
Setting for No.1 to No.9  
Setting value 【See: [Table 9.36] Editing crosspoint】

You can save the I/O channel settings and layout patterns into the crosspoint memory.  
Up to 9 crosspoint memories can be saved with their name (up to 10 characters, 20 to 7D in ASCII).

Press the "MENU/ENTER" button to apply the setting.

To update a crosspoint memory with "(---)" (not control) setting, select "CONTINUE" or "DELETE".

#### ■ For "(---)" (not control) setting

"CONTINUE" : The setting "(---)" (not control) will be kept in the crosspoint memory.

"DELETE" : The current input channel settings will be overwritten.

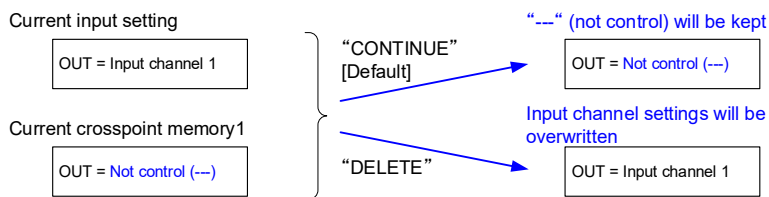

【Fig. 9.34】 Saving crosspoint

### 9.16.3 Editing crosspoint

Menu Top→USER PRESET→EDIT CROSSPOINT

Setting for No.1 to No.9

Setting value

[Table 9.36] Editing crosspoint

Setting item		Setting value
Output channel MAIN1, MAIN2	Layout pattern PinP	--- (not control) [Default], OFF, PATTERN 1 to PATTERN 5
	Video input channel VIDEO	--- (not control) [Default], 1 to 7, OFF
	Audio input channel AUDIO	--- (not control) [Default], 1 to 7, OFF
Output channel PinP1, PinP2	Video input channel VIDEO	--- (not control) [Default], 1 to 7, OFF
Memory name NAME	20 to 7D of ASCII code (up to 10 characters) [Default] ASCII (Text) No.1 : 31 (1), No.2 : 32 (2), No.3 : 33 (3), No.4 : 34 (4), No.5 : 35 (5), No.6 : 36 (6), No.7 : 37 (7), No.8 : 38 (8), No.9 : 39 (9)	

You can edit crosspoint memory settings.

Press the "MENU/ENTER" button to apply the setting.

#### ■ Not controlling channel

If you select "---" for "VIDEO", "AUDIO", or "PinP" setting, the channels are not controlled.

Outputs that are set not to be controlled are not switched when crosspoint memory is loaded.

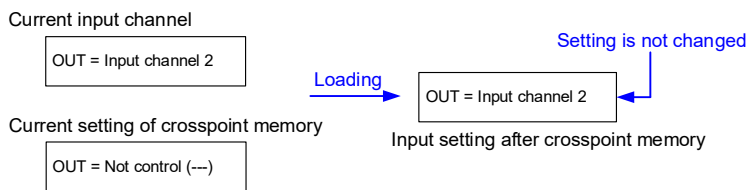

[Fig. 9.35] Loading edited crosspoint memory

### 9.16.4 Recalling preset memory

---

Menu	Top→USER PRESET→RECALL PRESET SETTINGS
Setting value	No.1 to No.8

You can recall settings that are saved in the preset memories.

【See: 9.16.5 Saving preset memory】

Press the "MENU/ENTER" button to apply the setting.

If a preset memory is saved, this menu is displayed and only saved number can be selected.

### 9.16.5 Saving preset memory

---

Menu	Top→USER PRESET→STORE PRESET SETTINGS
Setting for	No.1 to No.8

You can save up to 8 preset memories and name these memories up to 10 characters from ASCII 20 to 7D.

Press the "MENU/ENTER" button to apply the setting.

**[Table 9.37] Settings saved in preset memory**

Menu	Description
Selecting input channels	Selecting input channels (Video & Audio)
Layout pattern	Layout pattern
Output position, size, and masking	Output resolution, Aspect ratio for sink device, Image position, Image size, Cropping, Background color, Test pattern
Output	Presence of output signal for when signal is input, Presence of output signal for when no signal is input, HDCP output, HDCP retries, Output equalizer, Output format, HDBaseT output long reach mode, Deep Color output, Window transition effect, Window transition speed, CEC connection
Input position, size, and cropping	Aspect ratio, Aspect ratio control, Overscan, Image position, Image size, Cropping
Input	DVI input connector signal, No-signal input monitoring, HDCP input, Input equalizer, Analog input signal parameters, Automatic detection of video input interruption
Input timing	The total number of horizontal pixels, Horizontal start position, Horizontal active area, Vertical start position, Vertical active area, Automatic measurement of start position, Automatic setting of input timing, Tracking
Automatic input channel switching	Signal ON priority, Signal OFF priority, Ignoring duration after automatic switching, Channel switching mode of automatic switching
Picture controls	Output brightness, Output contrast, Output gamma, Input sharpness Input brightness, Input contrast, Input hue, Input saturation, Input black level
Output audio	Output audio, Output audio level, Audio mute, Output Lip Sync, Sampling frequency, Multi-channel audio output, Multi-channel audio output priority, Test tone
Input audio	Input audio, Input audio level offset, Input Lip Sync, Stable input audio wait
EDID	EDID selection, Input resolution, HDMI/DVI, Frame rate, Deep Color input, LPCM audio, AAC audio, Dolby Digital audio, Dolby Digital Plus audio, Dolby TrueHD audio, DTS audio, DTS-HD audio, Speaker configuration

### 9.16.6 Layout pattern

Menu	Top→USER PRESET→PinP PATTERN
Setting for	OUT1, OUT2
Setting value	OFF [Default], PATTERN 1to PATTERN 5

You can set the layout pattern.

【See: 8.2.4 Enabling window combination】

### 9.16.7 Copying output setting

Menu	Top→USER PRESET→COPY OUTPUT SETTINGS
Setting value	OUT1 → OUT2, OUT2 → OUT1

You can copy the setting of the selected output channel to other output channels.

Press the “MENU/ENTER” button to apply the setting.

【Table 9.38】 Setting to be copied

Menu	Description
Selecting input channels	Selecting input channels (Video & Audio)
Layout pattern	Layout pattern
Output position, size, and masking	Output resolution, Aspect ratio for sink device, Image position, Image size, Cropping, Background color, Test pattern
Output	Presence of output signal for when signal is input, Presence of output signal for when no signal is input, HDCP output, HDCP retries, Output equalizer, Output format, HDBaseT output long reach mode, Deep Color output, Window transition effect, Window transition speed, Sink device EDID check, CEC connection
Picture controls	Output brightness, Output contrast, Output gamma
Output audio	Output audio, Output audio level, Audio mute, Output Lip Sync, Sampling frequency, Multi-channel audio output, Multi-channel audio output priority, Test tone
Bitmap	Bitmap output, Background color, Aspect ratio, Image position, Assigning input channel, Start-up bitmap output
Overlay bitmap	Overlay bitmap output, Image position, Transparency, Blending

CEC connections take place on a one-to-one basis. Multiple HDMI inputs/outputs cannot be connected to the HDBaseT output. If the same HDMI input is set to connect to multiple HDMI and HDBaseT outputs, a channel is selected automatically in alphabetical or numerical order and the other outputs will not be connected.

【See: 9.4.13 CEC connection】

This menu is only for MSD-S52 and MSD-S72.

### 9.16.8 Start-up settings

Menu    Top→USER PRESET→START-UP

Setting value   

**[Table 9.39] Start-up setting**

Setting value	Description
LAST CHANNEL [Default]	Starts with the last settings last time the MSD-S powered off or standby mode.
CHANNEL OFF	Starts with the setting of I/O channel OFF.
CROSS POINT 1 to CROSS POINT 9	Starts with the channel settings saved in the selected crosspoint memory. For I/O channels that are set to "not control" in crosspoint memory and setting other than channel settings and settings last time the MSD-S powered off or standby mode will be applied.
PRESET MEMORY 1 to PRESET MEMORY 8	Starts with the settings saved in the preset memory. For settings that are not saved in preset memory, the MSD-S powered off or standby mode will be applied.

You can configure which settings will be applied at start-up.

## 9.17 Bitmap

You can set the bitmap that can be displayed on the main window and PinP window.

Up to four bitmap files can be saved to the MSD-S. One of these files can be output to main window and PinP window separately as an output video.

Features:

- Video can be enlarged but cannot be reduced.
- Video can be enlarged fully on window or with aspect ratio kept.
- Bitmap background color can be set.
- Bitmap can be assigned to input channels.
- Video that is being output can be captured as a bitmap.

It takes up to six seconds to output bitmap depending on resolution.

By saving the smaller resolution than output resolution, the time from selecting bitmap to display will be shorten.

Up to four images of bitmap and overlay bitmap in total can be saved from WEB browser.  
IDK's logo is saved by factory default.

【See: 9.18 Overlay bitmap】

### ■ Conditions of bitmap file

The MSD-S supports DIB (Device Independent Bitmap) with a header generally used for Windows, and those files must meet the following requirements:

【See: 8.3.5 Saving bitmap】

**[Table 9.40] Bitmap file condition**

Item	Condition
File header	"BITMAPFILEHEADER"
Information header	"BITMAPCOREHEADER" (for OS/2)/ "BITMAPINFOHEADER" (for Windows)
The number of colors	2 colors (monochrome, 1 bit), 16 colors (4 bits), 256 colors (8 bits), 16.77 million colors (TRUE COLOR, 24 bits)
Resolution	The maximum resolution: [Horizontal resolution × Vertical resolution × The number of bytes per pixel] = 8,388,608 bytes or less. If you save multiple bitmaps, the total bytes of all bitmaps should be 8,388,608 bytes or less. (Aspect ratio does not matter as long as it is within the maximum resolution). Bytes per pixel: 1 byte per pixel for 2 colors (monochrome, 1 bit), 16 colors (4 bits), and 256 colors (8 bits); 3 bytes per pixel for 16.77 million colors (TRUE COLOR, 24 bits)
Compression format	No compression (BI_RGB) 8 bit-run-length compression (BI_RLE8) 4 bit-run-length compression (BI_RLE4)

### 9.17.1 Bitmap output

Menu Top→BITMAP→BITMAP OUTPUT  
 Setting for ALL, MAIN1, MAIN2, PinP1, PinP2  
 Setting value OFF [Default] ON (BITMAP 1 ON to BITMAP 4 ON)

"MAIN" : The bitmap is displayed on the full main window.

"PinP" : The bitmap is displayed on the full PinP window.



[Fig. 9.36] Default bitmap

### 9.17.2 Background color

Menu Top→BITMAP→BACKGROUND COLOR  
 Setting for ALL, MAIN1, MAIN2  
 Setting value

[Table 9.41] Background color

Setting item	Setting value	Description
Bitmap number	1 to 4	Selects bitmap number. *Only numbers saved as bitmap can be selected.
LINK	ON [Default], OFF	"ON": Only Red (R) can be set. Settings for Green (G) and Blue (B) will track the setting value selected for Red (R).
R	0 to 255 [Default] 255 (White)	N/A
G	0 to 255 [Default] 255 (White)	
B	0 to 255 [Default] 255 (White)	

You can set the background color for main window.

If the bitmap is smaller than main window, the set background color is displayed.

If the bitmap is smaller than PinP window, the lower-layer video is displayed as its background.

### 9.17.3 Aspect ratio

Menu Top→BITMAP→ASPECT RATIO  
 Setting for ALL, MAIN1, MAIN2, PinP1, PinP2  
 Setting value

[Table 9.42] Aspect ratio

Setting item	Setting value	Description
Bitmap number	No.1 to No.4	Selects bitmap number. *Only numbers saved as bitmap can be selected.
Aspect ratio	AUTO [Default], THROUGH, FULL	Sets bitmap enlarging type.

You can set the enlarging type.

“AUTO”: With bitmap aspect ratio

“MAIN” : Full main window

“PinP” : Full PinP window

If the subwindow ratio and sink device aspect ratio are matched, the bitmap aspect ratio is applied.

【See: 9.3.2 Aspect ratio for sink device】

【See: 9.3.4 Image size】

If the bitmap is bigger than output resolution or PinP window, only a part of bitmap is displayed.

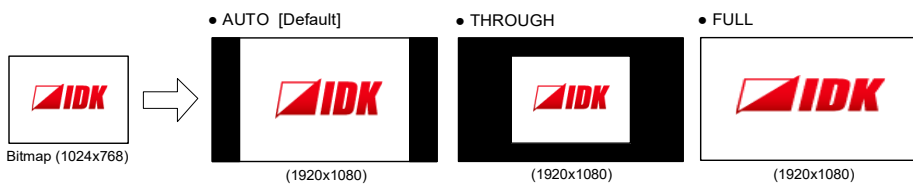

[Fig. 9.37] Setting aspect ratio

### 9.17.4 Image position

Menu Top→BITMAP→IMAGE POSITION

Setting for ALL, MAIN1, MAIN2

Setting value

[Table 9.43] Aspect ratio

Setting item	Setting value	Description
Bitmap number	No.1 to No.4	Selects bitmap number. *Only numbers saved as bitmap can be selected.
Image position	<ul style="list-style-type: none"> <li>• CENTER [Default]</li> <li>• TOP-LEFT</li> <li>• BOTTOM-LEFT</li> <li>• TOP-RIGHT</li> <li>• BOTTOM-RIGHT</li> </ul>	Selects image position.

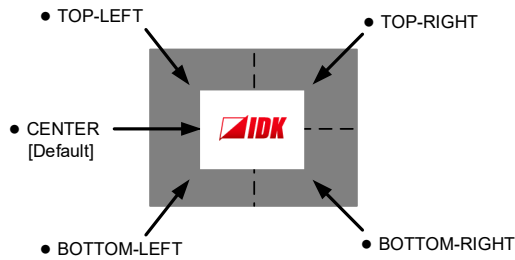

[Fig. 9.38] Position

For PinP window, the video is displayed at the upper left.

### 9.17.5 Assigning input channel

Menu Top→BITMAP→INPUT ASSIGN  
 Setting for ALL, MAIN1, MAIN2, PinP1, PinP2  
 Setting value

[Table 9.44] Assigning input channel

Setting item	Setting value	Description
Input channel	IN1 to IN7, OFF	Selects input channel to which bitmap is assigned.
Bitmap	OFF [Default]	No bitmap is assigned.
	BITMAP 1 ON	Selects bitmap number.
	BITMAP 2 ON	*Only numbers saved as bitmap can be selected.
	BITMAP 3 ON	
	BITMAP 4 ON	
BITMAP 4 ON		

A bitmap can be treated as an input video source by assigning the bitmap to any input that is not currently being used.

Larger resolutions require a longer loading time. While the bitmap is being displayed, other operation cannot be performed.

Press the "MENU/ENTER" button to apply the setting.

### 9.17.6 Start-up bitmap output

Menu Top→BITMAP→START-UP BITMAP  
 Setting for ALL, MAIN1, MAIN2, PinP1, PinP2  
 Setting value OFF [Default], ON (BITMAP 1 ON to BITMAP 4 ON)

You can enable/disable presenting a bitmap output at startup.

### 9.17.7 Dividing memory area

Menu Top→BITMAP→DIVIDE MEMORY

Setting value

[Table 9.45] Dividing memory area

Setting item	Setting value	Default
MODE (dividing mode)	RESIZE, AUTO, DELETE	RESIZE
NUMBER (the number of partitions)	1 to 4	1
DISPLAY (display unit)	BLOCK, BYTE	BLOCK
Setting memory area (Display by block)	0 to 127	127
Setting memory area (BYTE is selected)	0KB to 8192KB	8192KB

You can register up to four images in all (bitmap and overlay bitmap) within the available memory area by dividing the memory.

You can select one of three dividing modes or specify the size you want to divide manually.

Memory areas are controlled by blocks. 1 block = 65,536 bytes; 128 blocks = 8,388,608 bytes in total

Press the "MENU/ENTER" button to apply the setting.

■ Dividing mode

● RESIZE

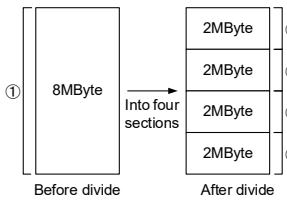

If no bitmap is registered, the memory is divided equally.

● AUTO

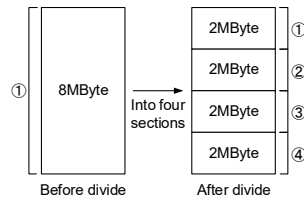

If no bitmap is registered, the memory is divided equally.

● DELETE

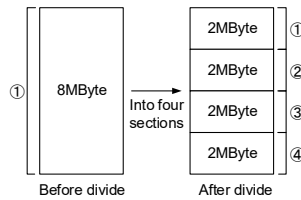

The memory area is divided equally regardless of whether bitmap is registered or not.

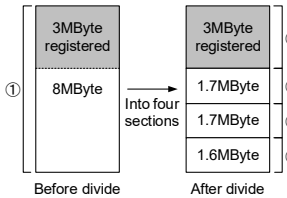

The area of the bitmap is limited to the bitmap size. The rest memory area is divided equally.

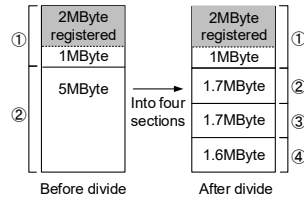

If a bitmap is registered, the area of the bitmap is kept. The rest memory area is divided equally.

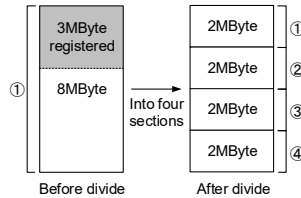

After divided, if the area of the bitmap is smaller than the bitmap size, the bitmap will be deleted.

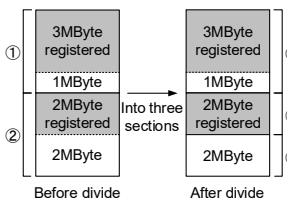

The start position of the area in which bitmap is registered is not changed. The area just before the registered bitmap is not resized.

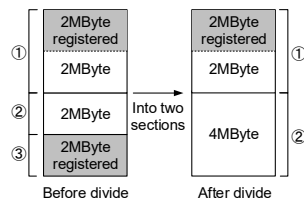

After divided, if the number of sections becomes smaller, the registered bitmap may be deleted.

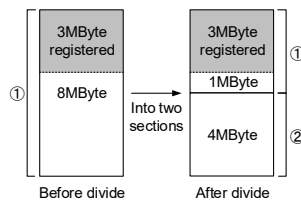

After divided, if the area of the bitmap is enough for the bitmap, the bitmap will not be deleted.

[Fig. 9.39] Dividing mode

■ **Displaying unit**

**"BLOCK"**

If you select "BLOCK" for "DISPLAY", the current start and end block positions are displayed on the left of the front panel display. If a bitmap is registered, the final block position is displayed in parentheses. The start and end block positions after divide are displayed on the right. If you want to specify the after-divide size directly, change the end block position.

If the currently-registered bitmap is deleted because of specifying the size directly, an "S" or "E" is displayed in the upper right.

**"BYTE"**

The currently-reserved memory size is displayed on the left. If a bitmap is registered, the number of bytes is displayed in parentheses. The memory size after dividing is displayed on the right so that you can specify directly the after-division memory size.

If the currently-registered bitmap is deleted because of specifying the size directly, an "S" or "E" is displayed in the upper right.

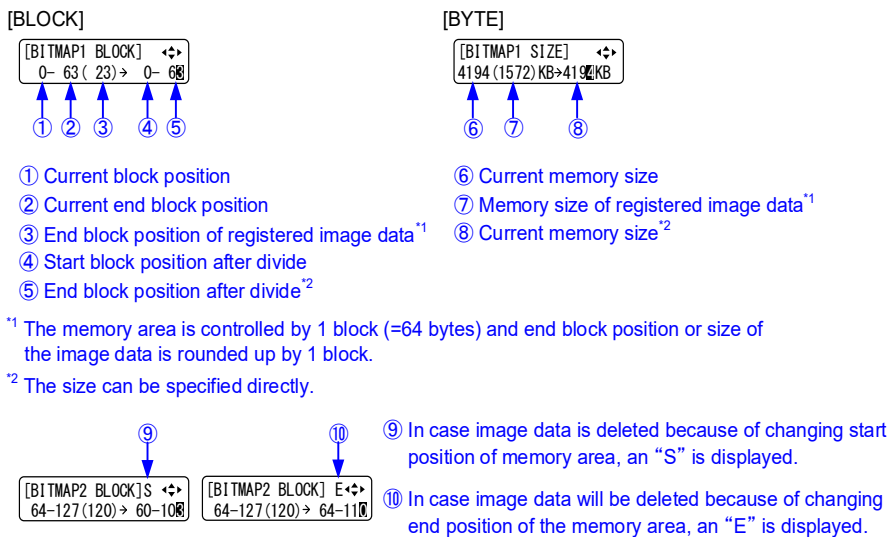

[Fig. 9.40] "BLOCK" and "BYTE"

### 9.17.8 Output image capture

Menu Top→BITMAP→CAPTURE VIDEO  
 Setting value

**[Table 9.46] Setting output image capture**

Setting item	Setting value
Output channel	MAIN1, MAIN2 [Default] MAIN1
Number	No.1 to No.4* [Default] No.1

\*Can be set if memory area is divided.

An input video can be treated as a bitmap by capturing and registering it. The maximum resolution is [Horizontal resolution × Vertical resolution ×3 (the number of bytes per pixel; "3" fixed)] 8,388,608 bytes or less. To register multiple bitmaps and captured images, the total resolution of all bitmaps and captured images should be 8,388,608 bytes or less (aspect ratio does not matter).

Captured images can be displayed at native size or enlarged, but cannot be reduced in size. Larger resolutions require a longer loading time; it may take approximately six seconds at a maximum. If using this menu for PinP window, the saving bitmap size needs to be the same size as the PinP window or smaller. You can register any images having a lower resolution by setting output resolution to smaller resolution and capturing the video.

To freeze the input video temporarily, press the "MENU/ENTER" button. To register the frozen image, select "YES" and then press the "MENU/ENTER" button again. To release freeze, press the "BACK" button. It can be released automatically when an input channel is switched or input signal changes.

If resolution of input video is too large compared to the reserved memory area, it can cause a significant memory shortage. In this case, message "MEMORY SIZE OVER" will be displayed after you press the "MENU/ENTER" button and registration will not be executed.

【See: 9.3.1 Output resolution】  
 【See: 9.17.7 Dividing memory area】

## 9.18 Overlay bitmap

You can set the overlay bitmap that is displayed on source image.

One image can be selected from four (at maximum) overlay bitmap files and can be displayed on the source image.

Features:

- Overlaid on the source image
- Output image is displayed at the same magnification.
- One color transparency (selectable)s
- Blending with source image

Overlay bitmap file can be saved from WEB browser, and up to four overlay bitmap and bitmap images in all can be saved.

**【See: 9.17 Bitmap】**

### ■ Overlay bitmap file

Overlay bitmap file with DIB (Device Independent Bitmap) with a header generally used for Windows can be saved to the MSD-S.

**【See: 8.3.5 Saving bitmap】**

**[Table 9.47] Available overlay bitmap file**

Item	Condition
File header	"BITMAPFILEHEADER"
Information header	"BITMAPCOREHEADER" (for OS/2)/ "BITMAPINFOHEADER" (for Windows)
The number of colors	256 colors (8 bits)
Resolution	The maximum resolution: [Horizontal resolution × Vertical resolution × The number of bytes per pixel] = 8,388,608 bytes or less. If you save multiple bitmaps, the total bytes of all bitmaps should be 8,388,608 bytes or less. (Aspect ratio does not matter as long as it is within the maximum resolution). Bytes per pixel: 1 byte per pixel for 2 colors (monochrome, 1 bit), 16 colors (4 bits), and 256 colors (8 bits); 3 bytes per pixel for 16.77 million colors (TRUE COLOR, 24 bits)
Compression format	No compression (BI_RGB) 8 bit-run-length compression (BI_RLE8) 4 bit-run-length compression (BI_RLE4)

### 9.18.1 Overlay bitmap output

Menu Top→OVERLAY BITMAP→OVERLAY BITMAP OUTPUT  
 Setting for ALL, OUT1, OUT2  
 Setting value

[Table 9.48] Overlay bitmap output

Setting value	Description
OFF [Default]	No overlay bitmap is output.
BITMAP 1 ON	Selects the saved bitmap number and outputs the overlay bitmap.
BITMAP 2 ON	
BITMAP 3 ON	
BITMAP 4 ON	

### 9.18.2 Image position

Menu Top→OVERLAY BITMAP→IMAGE POSITION  
 Setting for ALL, OUT1, OUT2  
 Setting value

[Table 9.49] Aspect ratio

Setting item	Setting value	Description
Bitmap number	No.1 to No.4	Selects the bitmap number. *Only numbers saved as overlay bitmap can be selected.
Image position	<ul style="list-style-type: none"> <li>• CENTER [Default]</li> <li>• TOP-LEFT</li> <li>• BOTTOM-LEFT</li> <li>• TOP-RIGHT</li> <li>• BOTTOM-RIGHT</li> </ul>	Sets display position on the main window.

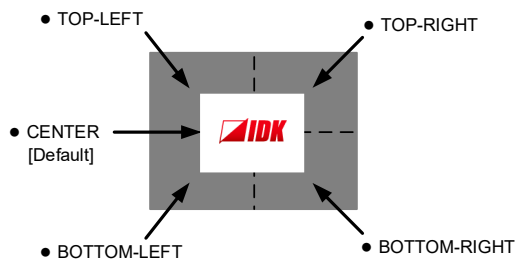

[Fig. 9.41] Position

### 9.18.3 Transparency

Menu  Top→OVERLAY BITMAP→TRANSPARENCY

Setting for  ALL, OUT1, OUT2

Setting value

[Table 9.50] Transparency

Setting item	Setting value	Description
Bitmap number	No.1 to No.4	Selects the overlay bitmap number.
Transparency	ON, OFF [Default]	Enables or disables transparency.
R	0 to 255 [Default] 0 (Black)	Specifies the color for transparency.
G	0 to 255 [Default] 0 (Black)	
B	0 to 255 [Default] 0 (Black)	

You can specify one color for the transparency target.

### 9.18.4 Blending

Menu  Top→OVERLAY BITMAP→BLENDING

Setting for  ALL, OUT1, OUT2

Setting value

[Table 9.51] Blending

Setting item	Setting value	Description
Bitmap number	No.1 to No.4	Selects the overlay bitmap number.
Blending rate	0 % to 100 % [Default] 100 %	Sets the blending rate. 100 %: No blending

## 9.19 Start-up setting

You can set the status at the time of start-up and powered on.

### 9.19.1 Power state

Menu  Top→POWER ON SETTINGS→START-UP MODE

Setting value

**[Table 9.52] Power state when POWER is on**

Setting value	Power state
AUTO [Default]	Starts with the last status
ON	Powered on
OFF	Standby

You can set the power status when the MSD-S is powered on using an external switch and at the time of power recovery.

### 9.19.2 Sending control command automatically

Menu  Top→POWER ON SETTINGS→FUNCTION CMD.EXE.

Setting for  F1 to F4, FN1, FN2

Setting value  OFF [Default], ON

When powered on, commands that are assigned to function buttons are sent automatically.  
The execution PLANE can be set at "START-UP".

**[See: 9.15.3 Command link]**

### 9.19.3 Front panel security lockout

Menu  Top→POWER ON SETTINGS→BUTTON LOCK

Setting value

**[Table 9.53] Button security lockout**

Setting value	Description
AUTO [Default]	As it was before powering off the MSD-S or entering standby mode.
LOCK	Enables front panel security lockout.
UNLOCK	Disables front panel security lockout.

You can select a front panel security lockout mode.

**[See: 9.20.3 Grouping front panel security lockout]**

**[See: 8.2.6 Front panel security lockout]**

## 9.20 Configuring MSD-S

---

### 9.20.1 PinP window setting

---

Menu Top→SYSTEM SETTINGS→WINDOW INPUT  
 Setting value MAIN [Default], PinP

You can set the input channel to which the video/audio is output.

MAIN : Video and audio of the main window  
 PinP : Video of PinP window

【See: 8.2.4 Enabling window combination】

### 9.20.2 Channel switching mode

---

Menu Top→SYSTEM SETTINGS→SWITCHING MODE  
 Setting value V&A : Video & Audio [Default]  
 VIDEO : Video  
 AUDIO : Audio

Video and audio input channels can be switched simultaneously or separately using the input selection button.

Amber : Video and audio simultaneously  
 Green : Video only  
 Red : Audio only

【See: 8.2.3 Selecting video and audio separately】

### 9.20.3 Grouping front panel security lockout

---

Menu Top→SYSTEM SETTINGS→BUTTON LOCK TARGET  
 Setting for CHANNEL, MENU, F BUTTON, FN BUTTON, STANDBY  
 Setting value

【Table 9.54】 Target buttons of security lockout

Setting for	Target button	Setting value
CHANNEL	“Input channel selection” buttons	LOCK [Default], UNLOCK
MENU	“MENU/ENTER” button, “Navigation” buttons	LOCK [Default], UNLOCK
F BUTTON	“Function” buttons	LOCK [Default], UNLOCK
FN BUTTON	“FN” buttons	LOCK [Default], UNLOCK
STANDBY	“Standby” button	LOCK [Default], UNLOCK

You can set front panel security lockout that prevents accidental changes to the controller settings.

【See: 8.2.6 Front panel security lockout】

### 9.20.4 Beep

Menu Top→SYSTEM SETTINGS→BEEP SOUND  
 Setting value ON, OFF [Default]

You can enable/disable the beep tone function (sounding every time you press a front panel button).

### 9.20.5 Alarm

Menu Top→SYSTEM SETTINGS→ALARM  
 Setting value ON : Enabling [Default]  
 OFF : Disabling

You can enable/disable the alarm function for abnormal internal temperature or cooling fan.

```
***** ALARM *****
      FAN TEMP
```

[Fig. 9.42] Alarm page

[Table 9.55] Alarm description

Displayed value	Description
FAN	Abnormality in cooling fan is detected.
TEMP	Abnormality in internal temperature is detected.

In case an alarm is output, the MSD-S may have problems. Please contact us.

### 9.20.6 Displaying advanced menu

Menu Top→SYSTEM SETTINGS→ADVANCED MENU  
 Setting value OFF : Displays normal setting menu [Default]  
 ON : Displays advanced setting menu

You can switch menu display mode: Normal setting menu or Advanced setting menu.

### 9.20.7 Power saving

Menu Top→SYSTEM SETTINGS→POWER SAVE MODE  
 Setting value ON [Default], OFF

If you select “ON” and no button function is operated for 30 seconds, the display brightness is reduced to approximately 25%. When you operate any button, brightness returns to 100%.

### 9.20.8 Button press dwelling time

Menu Top→SYSTEM SETTINGS→BUTTON HOLD TIME  
 Setting for F BUTTON, FN BUTTON  
 Setting value 0ms to 5000ms (by 100ms) [Default] 0ms

You can set the press dwelling time of function buttons. This feature prevents undesired operation by touching a button.

### 9.20.9 Top page

Menu Top→SYSTEM SETTINGS→TOP PAGE  
 Setting value

NORMAL [Default]

MSD-S72  
 [ V&A ]

SINK DEVICE STATUS

OUT1A 1B 2A 2B  
 S S S

INPUT STATUS

IN1 2 3 4 5 6 7  
 H<sup>2</sup> D H

AUDIO VOLUME

[DIGITAL] MUTE  
 0dBu

You can mute/unmute by pressing the “BACK” button.

[Fig. 9.43] Top page of front panel display

For the top page, you can select one of four types above.

With input signal status and sink device status pages, the details of each signal can be displayed using “▲” and “▼” buttons.

【See: 9.21.1 Sink device status】

【See: 9.21.3 Input signal status】

## 9.21 Status

### 9.21.1 Sink device status

Menu Top→VIEW STATUS→SINK DEVICE STATUS

Values to be displayed

[Table 9.56] Sink device status

	All output connectors	Each output connector
Display		
Upper	Output connector	Output connector, output signal, color depth, output format
Lower	HDCP status	HDCP status, error code

You can view the status of sink device connected to output connectors.

#### ■ Output signal and color depth

H24 : HDMI 24-BIT COLOR  
H30 : HDMI 30-BIT COLOR  
D : DVI

#### ■ Output format

Y444 : YCbCr 4:4:4 MODE  
Y422 : YCbCr 4:2:2 MODE  
RGB : RGB MODE

#### ■ HDCP authorization status

[Table 9.57] HDCP authorization status

Character	HDCP status	Description
S	HDCP SUPPORT	HDCP-compliant sink device is connected.
N	HDCP NOT SUPPORT	Non-HDCP-compliant sink device is connected.
E	HDCP ERROR	HDCP-compliant sink device is connected, but the authorization failed.
C	HDCP CHECK NOW	Sink device status is being checked.
D	SINK DEVICE DISCONNECT	Monitor was disconnected (displayed only for one second).
L	HDBaseT LINK DISCONNECT	Category cable was disconnected (displayed only for one second).
O	HDBaseT NO LINK	No category cable is connected.
	UNCONNECTED	No sink device is connected.

### ■ Error code

From the left to right, status of video output, digital audio output, and analog audio output is displayed.

[Table 9.58] Error code

Code	Video output	Audio output
	If any number or character is not displayed, video or audio is output correctly.	
1	<b>"9.4.1 Presence of output signal for when signal is input"</b> is set to "BLACK".	<b>"9.10.3 Audio mute"</b> is set to "ON".
2	Displayed only for digital input. DDC power supply is not input. (If no source device is connected, this error code is displayed).	
3	No video signal is input.	No audio signal is input.*
4	Displayed only for digital input. Video or audio output of source device is in a Mute status.	
5	Displayed only for digital input. Signal with HDCP are input, but the sink device does not support HDCP. (This error code may also be displayed while authenticating HDCP).	
6	Displayed only for digital input. The source device does not output required information (packets) for outputting video or audio.	
7	Signal that are not supported by the MSD-S are input. (Sampling clock is out of the range)	Signal that are not supported by the MSD-S are input. (Sampling clock is out of the range).
8	—	<b>"9.10.1 Output audio"</b> is set to "OFF".
9	—	<b>"9.4.7 Output format"</b> is set to "DVI MODE" or a sink device that does not support audio is connected.
A	Input channel is set to "OFF".	

\* Input status of analog audio signal cannot be detected. Even if this status is not displayed, audio may sometimes not be output when analog input is selected.

## 9.21.2 Viewing sink device EDID

Menu Top→VIEW STATUS→SINK DEVICE EDID

Values to be displayed

[Table 9.59] Sink device EDID

No.	1	2	3
Display	[OUT1A]xxxx 1920x1080 148.50MHz ↕	[OUT1A] HDMI RGB/YCbCr422/444 ↕  [OUT1A] DVI ↕	[OUT1A] 24/30/36BIT COLOR ↕
Upper	Output connector, monitor name	Output connector, HDMI or nothing is displayed	Output connector
Lower	Resolution, dot clock	Sampling RGB: RGB 422 : YCbCr 4:2:2 444 : YCbCr 4:4:4 420 : YCbCr 4:2:0 Or Non-HDMI-supported sink device DVI : DVI device	Color depth

No.	4	5
Display	[OUT1A] 32/44.1/48/96kHz ↕	[OUT1A] 16/20/24BIT 8CHANNEL COMPRESSED ↕
Upper	Output connector	Output connector, Audio bit length
Lower	Audio sampling frequency	Number of audio channels, compressed audio supported/not supported

You can display the EDID information of the sink device that is connected to each video output connector.

- HDMI supported sink device : No.1 to No.5 in the table above
- Non-HDMI-supported sink device : No.1 and No.2 in the table above

If no sink device is connected, the front panel display shows "UNCONNECTED". If the MSD-S cannot read EDID from connected sink devices, the front panel display (No.1) shows "EDID READ ERROR".

### 9.21.3 Input signal status

Menu Top→VIEW STATUS→INPUT STATUS

Values to be displayed

[Table 9.60] Input signal status

	All input channels	Video status of each input channel	Audio status of each input channel
Display			
Upper	Input channel	Input channel, color depth	Input channel, multi-channel audio information
Lower	Input signal type, other information	Video signal format, input signal type, other information	Audio signal type

You can view the input signal status that is input from HDMI and DVI input connectors.

#### ■ Input signal type

[Table 9.61] Input signal type

Alphabet	Signal	Alphabet	Signal
H	HDMI signal	R	Analog RGB signal
D	DVI signal	Y	Analog YPbPr signal
No alphabet	No signal is input.		

#### ■ Other information

Only for digital input

Upper: "H" : signal is protected by HDCP.

Lower: "A" : audio is embedded.

#### ■ Color depth

24 : 24-BIT COLOR

30 : 30-BIT COLOR

### ■ Video signal format

[Table 9.62] Video signal format

Example	Signal type	Description
1080p 59.94Hz	SDTV/HDTV signal	Format type, vertical sync frequency
800 x 600 60.00Hz	RGB signal	Horizontal/vertical resolution, vertical sync frequency
56.83kHz 60.02Hz	Signal that cannot be recognized	Horizontal/vertical sync frequency
NO SIGNAL	No video signal is input.	—

If the dot clock of the input signal exceeds the limitation, "E" is displayed on the left of the input signal type, and the video is not output.

[IN1 FORMAT]	24
3840x2160 30Hz	EH <sup>2</sup> ↕

### ■ Multi-channel audio information

If multi-channel audio signal is input, an "M" is displayed on the upper right.

### ■ Audio signal type

[Table 9.63] Audio signal type

Example	Signal type
Linear PCM 48kHz	LPCM, sampling frequency
COMPRESSED AUDIO	Compressed audio (such as Dolby Digital, DTS)
NO SIGNAL	No audio signal is input.

### 9.21.4 System status

Menu    Top→VIEW STATUS→SYSTEM STATUS

Setting value   



[Fig. 9.44] System status

[Table 9.64] System status

Displayed value	Description
OK	No abnormality is detected.
FAN	Abnormality in rotation speed is detected.
TEMP	Abnormality in internal temperature is detected.

You can view the internal temperature and fan status.

In case an abnormality is detected and the alarm is set to "ON", the alarm is displayed on the front.

[See: 9.20.5 Alarm]

In case an alarm is output, the MSD-S may have problems. Please contact us.

### 9.21.5 Fan status

Menu    Top→VIEW STATUS→FAN STATUS

Setting value   

You can view fan rotation speed and fan status.

"O" means normal, and "x" means abnormal.

In case an alarm is output, the MSD-S may have problems. Please contact us.

### 9.21.6 Device information

Menu    Top→VIEW STATUS→VERSION

Values to be displayed    Model name and firmware version

You can view the model name and firmware version.

### 9.21.7 HDBaseT status

Menu  Top→VIEW STATUS→HDBT STATUS

Values to be displayed

You can view HDBaseT information.

**[Table 9.65] HDBaseT status**

Item	Value to be displayed	Description
LOCAL TYPE Device type	VS100TX	—
LOCAL VER. Version ID	13.07.21.10	—
LOCAL MODE Operation mode	HDBaseT	HDBaseT mode
	Long Reach	Long reach mode
	LPPF1	LPPF1 mode
	LPPF2	LPPF2 mode
	HDBT NO LINK	Not connected
REMOTE TYPE Connected device type	VS100RX	—
REMOTE VER. Connected version ID	13.07.21.00	—
CABLE LEN. Category cable length	UNDER 20 m	66 ft. (20 m) or shorter
	OVER 100 m	328 ft. (100 m) or longer
	80 m	Category cable length Example: 262 ft. (80 m)
	HDBT NO LINK	Not connected
BER Bit error rate	10e10	Signal bit error rate Example: 10e <sup>-10</sup>
	HDBT NO LINK	Not connected
FMSEERR Signal quality (FMSEERR CURRENT VALUE)	-22 -20 -21 -22	Example: A=-22dB B=-20dB C=-21dB D=-22dB
	HDBT NO LINK	Not connected
FMSEERR MAX Maximum signal quality (FMSEERR MAX VALUE)	-22 -20 -21 -22	Example: A=-22dB B=-20dB C=-21dB D=-22dB
	HDBT NO LINK	Not connected
FMAXERR Residual gap (FMAXERR CURRENT VALUE)	0.34 0.35 0.32 0.33	Example: A=0.34 B=0.35 C=0.32 D=0.33
	HDBT NO LINK	Not connected
FMAXERR MAX Maximum residual gap (FMAXERR MAX VALUE)	0.34 0.35 0.32 0.33	Example: A=0.34 B=0.35 C=0.32 D=0.33
	HDBT NO LINK	Not connected

The displayed values may differ from real value depending on environment.

To display those information as a list, use WEB browser.

**[See: 8.3 WEB browser operations]**

## 9.22 Factory default list

[1/6]

Menu		Factory default
OUTPUT IMAGE	RESOLUTION	AUTO-A
	ASPECT RATIO	RESOLUTION
	IMAGE POSITION	@1080p [MAIN] Layout pattern: — (OFF) H 0/V 0 Layout pattern: P1 to P4 H 0/V 0 Layout pattern: P5 H 0/V 270 [PinP] Layout pattern: — (OFF) —(N/A) Layout pattern: P1 H 80/V 45 Layout pattern: P2 H 1360/V 45 Layout pattern: P3 H 80/V 765 Layout pattern: P4 H 1360/V 765 Layout pattern: P5 H 960/V 270
	IMAGE SIZE	@1080p [MAIN] Layout pattern: — (OFF) H 1920/V 1080 Layout pattern: P1 to P4 H 1920/V 1080 Layout pattern: P5 H 960/V 540 [PinP] Layout pattern: — (OFF) —(N/A) Layout pattern: P1 to P4 H 480/V 270 Layout pattern: P5 H 960/V 540
IMAGE CROP	@1080p [MAIN] Layout pattern: — (OFF) L 0/R 1920/T 0/B 1080 Layout pattern: P1 to P4 L 0/R 1920/T 0/B 1080 Layout pattern: P5 L 0/R 960/T 270/B 810 [PinP] Layout pattern: — (OFF) —(N/A) Layout pattern: P1 L 80/R 560/T 45/B 315 Layout pattern: P2 L 1360/R 1840/T 45/B 315 Layout pattern: P3 L 80/R 560/T 765/B 1035 Layout pattern: P4 L 1360/R 1840/T 765/B 1035 Layout pattern: P5 L 960/R 1920/T 270/B 810 (No cropping)	

Menu	Factory default
OUTPUT IMAGE	BACKGROUND COLOR R : 0 G : 0 B : 0 (Black)
	TEST PATTERN Pattern outputting : OFF Scrolling : OFF
	IMAGE INITIALIZATION —
OUTPUT SETTINGS	OUTPUT SIGNAL SOURCE
	NO SIGNAL IMAGE BLUE
	HDCP OUTPUT MODE ALWAYS
	HDCP RETRY ETERNITY (retries until succeed)
	CONNECTION RESET —
	SIGNAL EQUALIZATION OFF
	SIGNAL FORMAT HDMI YCbCr 4:4:4 MODE
	HDBT LONG REACH MODE OFF
	Deep Color output 24-BIT COLOR
	VIDEO SWITCHING EFFECT FREEZE→FADE OUT-IN
	SWITCHING EFFECT SPEED 350ms
	EDID ERR. OUTPUT MODE CHECKSUM DISABLE
	CEC CONNECTION NOT CONNECTED
INPUT IMAGE	ASPECT RATIO AUTO-1
	ASPECT RATIO CONTROL L-BOX/S-PANEL
	OVERSCAN SDTV : 105% HDTV/PC : 100%
	IMAGE POSITION H 0/V 0
	IMAGE SIZE H 1920/V 1080 @1080p (Output resolution pixels)
	IMAGE CROP L 0/R 1920/T 0/B 1080 (No cropping) @1080p (Output resolution pixels)
	IMAGE INITIALIZATION —
INPUT SETTINGS	DVI-I: SIGNAL FORMAT DIGITAL
	NO INPUT MONITORING 10000ms
	HDCP INPUT MODE ENABLE
	SIGNAL EQUALIZATION ON
	ANALOG INPUT FORMAT AUTO
	INTERRUPTION DETECTION ON
	SIGNAL SETTING MODE [Setting mode] SELECTED [Individual setting] ASPECT RATIO : OFF ANALOG INPUT FORMAT : ON(FIXED) INPUT LEVEL OFFSET : ON(FIXED)

Menu	Factory default	
INPUT TIMING	ANALOG MEASUREMENT	NORMAL MODE
	H TOTAL PIXELS	0 (To be set automatically when signal is input)
	H START POSITION	0 (To be set automatically when signal is input)
	H ACTIVE	0 (To be set automatically when signal is input)
	V START POSITION	0 (To be set automatically when signal is input)
	V ACTIVE	0 (To be set automatically when signal is input)
	START POSITION DETECT.	ON
	UNREGISTERED SIGNAL	AUTO SETUP ON
	INPUT TIMING INIT.	—
	RECALL ANALOG SETTINGS	—
	STORE ANALOG SETTINGS	All 99 dives are not registered.
ANALOG SIGNAL TRACKING	0 (To be set automatically when signal is input)	
AUTO SWITCHING	SIGNAL ON PRIORITY	OFF
	SIGNAL OFF PRIORITY	OFF
	IGNORING DURATION	0s000ms
	SWITCHING MODE	V&A
PICTURE ADJUSTMENT	OUTPUT BRIGHTNESS	100%
	OUTPUT CONTRAST	R : 100% G : 100% B : 100%
	OUTPUT GAMMA	1.0
	OUTPUT SETTING INIT.	—
	INPUT SHARPNESS	0
	INPUT BRIGHTNESS	100%
	INPUT CONTRAST	R : 100% G : 100% B : 100%
	INPUT HUE	0°
	INPUT SATURATION	100%
	INPUT BLACK LEVEL	0.0%
	INPUT SETTING INIT.	—
OUTPUT AUDIO SETTINGS	OUTPUT SIGNAL	ON
	OUTPUT LEVEL	0dB
	MUTE	OFF
	LIP SYNC	0ms
	SAMPLING FREQUENCY	AUTO-A
	DOWNMIX	DOWNMIX
	OUTPUT PRIORITY	MULTI
	TEST TONE	Test tone : OFF Speaker : ALL
INPUT AUDIO SETTINGS	INPUT SIGNAL	DIGITAL
	INPUT LEVEL OFFSET	0dB
	LIP SYNC	0ms
	STABLE WAIT	ON

Menu	Factory default	
EDID SETTINGS	EDID SELECTION	BUILT-IN EDID
	RESOLUTION	1080p(1920x1080)
	SINK DEVICE EDID COPY	All 8 COPY DATA is not saved.
	SIGNAL FORMAT	HDMI
	FRAME RATE	60Hz
	Deep Color input	24-BIT COLOR
	Linear PCM	48kHz
	AAC	OFF
	Dolby Digital	OFF
	Dolby Digital Plus	OFF
	Dolby TrueHD	OFF
	DTS	OFF
	DTS-HD	OFF
	SPEAKER CONFIGURATION	MODE : AUTO NUMBER : 2ch (FL/FR)
RS-232C SETTINGS	PARAMETERS	Baud rate : 9600bps Data bit length: 8bit Parity check : NONE Stop bit : 1 bit
	COMMUNICATION MODE	RS : RECEIVER HDBT OUT1B: TRANSMITTER HDBT OUT2B: TRANSMITTER
LAN SETTINGS	IP ADDRESS	192.168.1.199
	SUBNET MASK	255.255.255.0
	GATEWAY	192.168.1.200
	MAC ADDRESS	MAC address is displayed.
	PORT NUMBER	Connection 1 to 3 : 1100 Connection 4 to 6 : 23 Connection 7 to 8 : 80
	COMMUNICATION MODE	RECEIVER
	HDBT COMMUNICATION	ON

Menu	Factory default	
CONTROL COMMAND	COMMAND REGISTER/EDIT	32 commands are not registered.
	REPLY REGISTER/EDIT	REPLY1 to REPLY30 : Not registered REPLY31 : OK REPLY32 : NG
	COMMAND LINK	45 commands are not registered.
	EXECUTE CTRL COMMAND	—
	INITIALIZATION	—
	INVALID DURATION	0s000ms
	ILLUMINATE FN. BUTTON	F1 to F9 : REGISTERED FN1, FN2 : EXECUTION
	BLINKING DURATION	F1 to F4 : OFF FN1, FN2 : EXECUTION
	FUNCTION ASSIGN	COMMAND
USER PRESET	RECALL CROSSPOINT	—
	STORE CROSSPOINT	All 9 crosspoint memories are not saved.
	EDIT CROSSPOINT	Output channel (OUT) : — (not control) Video input channel (VIDEO) : — (not control) Audio input channel (AUDIO) : — (not control) Memory name (NAME) : No.1 : 31 (1) No.2 : 32 (2) No.3 : 33 (3) No.4 : 34 (4) No.5 : 35 (5) No.6 : 36 (6) No.7 : 37 (7) No.8 : 38 (8) No.9 : 39 (9)
	RECALL PRESET SETTINGS	—
	STORE PRESET SETTINGS	All 8 preset memories are not saved.
	PinP PATTERN	OFF
	COPY OUTPUT SETTINGS	—
	START-UP	LAST CHANNEL

Menu	Factory default	
BITMAP	BITMAP OUTPUT	OFF
	BACKGROUND COLOR	R : 255 G : 255 B : 255 (White)
	ASPECT RATIO	AUTO
	IMAGE POSITION	CENTER
	INPUT ASSIGN	OFF
	START-UP BITMAP	OFF
	DIVIDE MEMORY	1 bitmap 127 blocks memory
	CAPTURE VIDEO	-
OVERLAY BITMAP	OVERLAY BITMAP OUTPUT	OFF
	IMAGE POSITION	CENTER
	TRANSPARENCY	Transparency : OFF Color : R : 0 G : 0 B : 0 (Black)
	BLENDING	100 %
POWER ON SETTINGS	START-UP MODE	AUTO
	FUNCTION CMD.EXE.	OFF
	BUTTON LOCK	AUTO
SYSTEM SETTINGS	WINDOW INPUT	MAIN
	SWITCHING MODE	V&A
	BUTTON LOCK TARGET	LOCK
	BEEP SOUND	OFF
	ALARM	ON
	ADVANCED MENU	OFF
	POWER SAVE MODE	ON
	BUTTON HOLD TIME	0ms
TOP PAGE	NORMAL	
VIEW STATUS	SINK DEVICE STATUS	—
	SINK DEVICE EDID	—
	INPUT STATUS	—
	SYSTEM STATUS	—
	FAN STATUS	—
	VERSION	—
	HDBT STATUS	—

## 10 Specification

### 10.1 DVI input connector

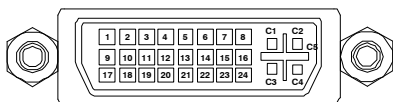

[Fig. 10.1] Female DVI-I (29-pin)

[Table 10.1] Pin-assignments

Pin#	HDMI/DVI	Analog RGB	Analog YPbPr
1	TMDS Data2-	N.C.	N.C.
2	TMDS Data2+	N.C.	N.C.
3	GND	N.C.	N.C.
4	N.C.	N.C.	N.C.
5	N.C.	N.C.	N.C.
6	DDC Clock	DDC Clock	N.C.
7	DDC Data	DDC Data	N.C.
8	N.C.	V-Sync	N.C.
9	TMDS Data1-	N.C.	N.C.
10	TMDS Data1+	N.C.	N.C.
11	GND	N.C.	N.C.
12	N.C.	N.C.	N.C.
13	N.C.	N.C.	N.C.
14	+5V Power	N.C.	N.C.
15	GND	N.C.	N.C.
16	Hot Plug Detect	N.C.	N.C.
17	TMDS Data0-	N.C.	N.C.
18	TMDS Data0+	N.C.	N.C.
19	GND	N.C.	N.C.
20	N.C.	N.C.	N.C.
21	N.C.	N.C.	N.C.
22	GND	N.C.	N.C.
23	TMDS Clock+	N.C.	N.C.
24	TMDS Clock-	N.C.	N.C.
C1	N.C.	Red	Pr/Cr
C2	N.C.	Green/SOG	Y
C3	N.C.	Blue	Pb/Cb
C4	N.C.	H-Sync/CS	N.C.
C5	N.C.	GND	GND

N.C.: No Connection, CS: Composite Sync

コメントの追加 [久中1]: 後でなおす

## 10.2 Product specification

### 10.2.1 MSD-S51

Item		Description
Input	Video	HDMI/DVI <p>5 inputs DVI connector: Switch-selectable between digital and analog HDMI/DVI 1.0 TMDS single link, HDCP 1.4 TMDS clock: 25 MHz to 225 MHz, TMDS data rate: 0.75 Gbps to 6.75 Gbps 30 bit Deep Color/CEC (HDMI connector only) .x.v.Color/3D/ARC/HEC/HDR are not supported. Built-in cable EQ, EDID emulation Connector: 4 female HDMI Type A (19-pin), 1 female DVI-I (29-pin)</p>
		Universal Analog <p>1 input Switch-selectable between digital and analog Analog RGB : 0.7 V<sub>[p-p]</sub>/75 Ω HS/VS TTL level Analog YPbPr : 1.0 V<sub>[p-p]</sub>(Y)/0.7 V<sub>[p-p]</sub>(Pb/Pr)/75 Ω EDID emulation Connector: 1 female DVI-I (29-pin)</p>
		Format <p>HDMI/DVI VGA to QWXGA (Dot clock: 25 MHz to 165 MHz) For WUXGA/QWXGA, only Reduced Blanking is supported. 480i / 480p / 576i / 576p / 720p / 1080i / 1080p</p> <p>Universal Analog VGA to QWXGA (Dot clock: 25 MHz to 165 MHz) For WUXGA/QWXGA, only Reduced Blanking is supported. 480i / 480p / 576i / 576p / 720p / 1080i / 1080p</p>
	Audio	Digital <p>5 inputs Switch-selectable between analog audio Multi-channel LPCM up to 8 channels Sampling frequency: 32 kHz to 192 kHz, Sample size: 16 bit to 24 bit Reference level: -20 dBFS, Max. input level: 0 dBFS Connector: 4 female HDMI Type A (19-pin), 1 female DVI-I (29-pin)</p>
		Analog <p>3 inputs Switch-selectable between digital audio Unbalanced Stereo LR Input impedance: 24 kΩ Reference level: -10 dBu, Max. input level: +10 dBu Connector: 3 captive screw (3-pin)</p>
	Output	Video
HDBaseT <p>1 output Video can be distributed to an HDMI/DVI output and an HDBaseT output simultaneously. HDBaseT HDCP 1.4 30 bit Deep Color/CEC .x.v.Color/3D/ARC/HEC/HDR are not supported. RS-232C/LAN Connector: 1 RJ-45 (*1) Cable: CAT.5E HDC, Cat5e UTP/STP, Cat6 UTP/STP (T568A/T568B straight-through)</p>		
Format <p>VGA / XGA / WXGA (1280x768) / WXGA (1280x800) / Quad-VGA / SXGA / WXGA (1360x768) / WXGA (1366x768) / SXGA+ / WXGA+ / WXGA++ / UXGA / WSXGA+ / VESAHD / WUXGA / QWXGA For VESAHD/WUXGA/QWXGA, only Reduced Blanking is supported. 480p / 576p / 720p / 1080i / 1080p</p>		
Audio		Digital <p>1 x 2 outputs Audio can be distributed to an HDMI/DVI output and an HDBaseT output simultaneously. Multi-channel LPCM up to 8 channels Sampling frequency: 32 kHz to 192 kHz, Sample size: 16 bit to 24 bit Reference level: -20 dBFS, Max. output level: 0 dBFS Connector: 1 female HDMI Type A (19-pin), 1 RJ-45</p>
		Analog <p>1 output Unbalanced Stereo LR Output impedance: 50 Ω Reference level: -10 dBu, Max. output level: +10 dBu Connector: 1 captive screw (3-pin)</p>

## MSD-S Series User Guide

Item	Description	
Maximum transmission distances	Digital input	HDMI/DVI : 98 ft. (30 m) (*2)
	Digital output	HDMI/DVI : 164 ft. (50 m) (*2) HDBaseT : 328 ft. (100 m), 492 ft. (150 m) (Long reach mode is used) (*3)
Control	RS-232C	1 port/captive screw (3-pin)
	LAN	1 port/RJ-45 10Base-T/100Base-TX (Auto Negotiation), Auto MDI/MDI-X
	Contact closure	3 ports/captive screw (6-pin) Non-voltage contact input up to DC 24 V 1 A
	External control	RS-232C, LAN, HDBaseT, Contact closure, PLink (class1), CEC (Power control of sink device) (*4)
Functions	Video	Motion adaptive interlaced/progressive conversion, Aspect ratio control, Picture adjustment (brightness, contrast, image position, image size, etc.), Seamless Switching, Two video combinations: PinP and side-by-side, Pattern memory (5 settings), Each video output OFF, Bitmap display
	Audio	Input level offset control, Output level control, Lip Sync (Max. 70 ms.), Audio Downmix
	Others	WEB browser control, Automatic input channel switching, Audio breakaway for independent audio and video switching, Crosspoint memory (9 settings), Preset memory (8 settings), Last memory, Anti-Snow, Connection Reset (*5), External control commands (32 commands), Button security lockout, System check, HDBaseT status display, Standby switch
General	Power	100 - 240 VAC ±10%, 50 Hz/60 Hz ±3 Hz
	Power consumption	About 33 Watts
	Dimensions	16.9 (W) × 1.7 (H) × 11.8 (D)" (430 (W) × 44 (H) × 300 (D) mm) (1U high) (Excluding connectors and the like)
	Weight	9 lbs. (4.1 kg)
	Temperature	Operating : 32°F to 104°F (0°C to +40°C) Storage : -4°F to +176°F (-20°C to +80°C)
	Humidity	Operating/Storage: 20% to 90% (Non Condensing)

\*1 RJ-45 (HDBaseT connector) is only for extending digital video and audio signals over a Cat5e/Cat6 cable. Use it with IDK's HDBaseT Products. Do not use for LAN devices.

\*2 The maximum cable distance varies depending on the connected devices and was measured under following conditions:  
- 1080p@60. When IDK's 24 AWG cable was used and signals of 1080p@60 24 bit/pixel (8 bit/component) was input or output.

The maximum cable distance depends on the connected devices. The distance may not be extended with some device combinations, cabling method, or other manufacturer's cable. Video may be disturbed or may not be output even if signals are within the range mentioned above.

\*3 The maximum transmission distance was obtained when IDK's CAT.5E HDC cable was used. The distance may not be extended with some device combinations, cabling method, or other manufacturer's cable. Video may be disturbed or may not be output even if signals are within the range mentioned above.  
The maximum transmission distance is the shorter distance of connected HDBaseT product or sink device's maximum transmission distance.

\*4 Some sink devices cannot be controlled from the MSD-S through CEC.

\*5 For digital systems, some problems, such as an HDCP authentication error, can often be recovered by physically disconnecting and reconnecting the digital cables. However, the Connection Reset feature will fix these problems automatically without the need to physically plug and unplug the cables. It creates the same condition as if the cable were physically disconnected and reconnected. This feature only works for the MSD-S's output. If other devices are connected between the MSD-S's output and sink device, this feature may be invalid.

## 10.2.2 MSD-S52

Item		Description	
Input	Video	HDMI/DVI 5 inputs DVI connector: Switch-selectable between digital and analog HDMI/DVI 1.0 TMDS single link, HDCP 1.4 TMDS clock: 25 MHz to 225 MHz, TMDS data rate: 0.75 Gbps to 6.75 Gbps 30 bit Deep Color/CEC (HDMI connector only) x.v.Color/3D/ARC/HEC/HDR are not supported. Built-in cable EQ, EDID emulation Connector: 4 female HDMI Type A (19-pin), 1 female DVI-I (29-pin)	
		Universal Analog 1 input Switch-selectable between digital and analog Analog RGB : 0.7 V[p-p]/75 Ω HS/VS TTL level, CS TTL level Analog YPbPr : 1.0 V[p-p](Y)/0.7 V[p-p](Pb/Pr)/75 Ω EDID emulation Connector: 1 female DVI-I (29-pin)	
		Format	HDMI/DVI VGA to QWXGA (Dot clock: 25 MHz to 165 MHz) For WUXGA/QWXGA, only Reduced Blanking is supported. 480i / 480p / 576i / 576p / 720p / 1080i / 1080p
			Universal Analog VGA to QWXGA (Dot clock: 25 MHz to 165 MHz) For WUXGA/QWXGA, only Reduced Blanking is supported. 480i / 480p / 576i / 576p / 720p / 1080i / 1080p
	Audio	Digital 5 inputs Switch-selectable between digital and analog Multi-channel LPCM up to 8 channels Sampling frequency: 32 kHz to 192 kHz, Sample size: 16 bit to 24 bit Reference level: -20 dBFS, Max. input level: 0 dBFS Connector: 4 female HDMI Type A (19-pin), 1 female DVI-I (29-pin)	
		Analog 3 inputs Switch-selectable between digital and analog Unbalanced Stereo LR Input impedance: 24 kΩ Reference level: -10 dBu, Max. input level: +10 dBu Connector: 3 captive screw (3-pin)	
Output	Video	HDMI/DVI 2 outputs Video can be distributed to HDMI/DVI outputs and HDBaseT outputs simultaneously. HDMI/DVI 1.0 TMDS single link, HDCP 1.4 TMDS clock: 25.175 MHz to 202.5 MHz, TMDS data rate: 0.75 Gbps to 6.075 Gbps 30 bit Deep Color/CEC x.v.Color/3D/ARC/HEC/HDR are not supported. Built-in cable EQ Connector: 2 female HDMI Type A (19-pin)	
		HDBaseT 2 outputs Video can be distributed to HDMI/DVI outputs and HDBaseT outputs simultaneously. HDBaseT HDCP 1.4 30 bit Deep Color/CEC x.v.Color/3D/ARC/HEC/HDR are not supported. RS-232C/LAN Connector: 2 RJ-45 (*1) Cable: CAT.5E HDC, Cat5e UTP/STP, Cat6 UTP/STP (T568A/T568B straight-through)	
		Format VGA / XGA / WXGA (1280x768) / WXGA (1280x800) / Quad-VGA / SXGA / WXGA (1366x768) / WXGA (1366x768) / SXGA+ / WXGA+ / WXGA++ / UXGA / WSXGA+ / VESAHD / WUXGA / QWXGA For VESAHD/WUXGA/QWXGA, only Reduced Blanking is supported. 480p / 576p / 720p / 1080i / 1080p	
	Audio	Digital 2 x 2 outputs Audio can be distributed to HDMI/DVI outputs and HDBaseT outputs simultaneously. Multi-channel LPCM up to 8 channels Sampling frequency: 32 kHz to 192 kHz, Sample size: 16 bit to 24 bit Reference level: -20 dBFS, Max. output level: 0 dBFS Connector: 2 female HDMI Type A (19-pin), 2 RJ-45	
		Analog 2 outputs Unbalanced Stereo LR Output impedance: 50 Ω Reference level: -10 dBu, Max. output level: +10 dBu Connector: 2 captive screw (3-pin)	

## MSD-S Series User Guide

Item	Description	
Maximum transmission distances	Digital input	HDMI/DVI : 98 ft. (30 m) (*2)
	Digital output	HDMI/DVI : 164 ft. (50 m) (*2) HDBaseT : 328 ft. (100 m), 492 ft. (150 m) (Long reach mode is used) (*3)
Control	RS-232C	1 port/captive screw (3-pin)
	LAN	1 port/RJ-45 10Base-T/100Base-TX (Auto Negotiation), Auto MDI/MDI-X
	Contact closure	3 ports/captive screw (6-pin) Non-voltage contact input up to DC 24 V 1 A
	External control	RS-232C, LAN, HDBaseT, Contact closure, PLink (class1), CEC (Power control of sink device) (*4)
Functions	Video	Motion adaptive interlaced/progressive conversion, Aspect ratio control, Picture adjustment (brightness, contrast, image position, image size, etc.), Seamless Switching, Two video combinations: PinP and side-by-side, Pattern memory (5 settings), Each video output OFF, Bitmap display
	Audio	Input level offset control, Output level control, Lip Sync (Max. 70 ms.), Audio Downmix
	Others	WEB browser control, Automatic input channel switching, Audio breakaway for independent audio and video switching, Crosspoint memory (9 settings), Preset memory (8 settings), Last memory, Anti-Snow, Connection Reset (*5), External control commands (32 commands), Button security lockout, System check, HDBaseT status display, Standby switch
General	Power	100 - 240 VAC ±10%, 50 Hz/60 Hz ±3 Hz
	Power consumption	About 44 Watts
	Dimensions	16.9 (W) × 1.7 (H) × 11.8 (D)" (430 (W) × 44 (H) × 300 (D) mm) (1U high) (Excluding connectors and the like)
	Weight	9 lbs. (4.1 kg)
	Temperature	Operating : 32°F to 104°F (0°C to +40°C) Storage : -4°F to +176°F (-20°C to +80°C)
	Humidity	Operating/Storage: 20% to 90% (Non Condensing)

\*1 RJ-45 (HDBaseT connector) is only for extending digital video and audio signals over a Cat5e/Cat6 cable. Use it with IDK's HDBaseT Products. Do not use for LAN devices.

\*2 The maximum cable distance varies depending on the connected devices and was measured under following conditions:  
- 1080p@60. When IDK's 24 AWG cable was used and signals of 1080p@60 24 bit/pixel (8 bit/component) was input or output.

The maximum cable distance depends on the connected devices. The distance may not be extended with some device combinations, cabling method, or other manufacturer's cable. Video may be disturbed or may not be output even if signals are within the range mentioned above.

\*3 The maximum transmission distance was obtained when IDK's CAT.5E HDC cable was used. The distance may not be extended with some device combinations, cabling method, or other manufacturer's cable. Video may be disturbed or may not be output even if signals are within the range mentioned above.  
The maximum transmission distance is the shorter distance of connected HDBaseT product or sink device's maximum transmission distance.

\*4 Some sink devices cannot be controlled from the MSD-S through CEC.

\*5 For digital systems, some problems, such as an HDCP authentication error, can often be recovered by physically disconnecting and reconnecting the digital cables. However, the Connection Reset feature will fix these problems automatically without the need to physically plug and unplug the cables. It creates the same condition as if the cable were physically disconnected and reconnected. This feature only works for the MSD-S's output. If other devices are connected between the MSD-S's output and sink device, this feature may be invalid.

## 10.2.3 MSD-S71

Item		Description	
Input	Video	HDMI/DVI 7 inputs DVI connectors: Switch-selectable between digital and analog HDMI/DVI 1.0 TMDS single link, HDCP 1.4 TMDS clock: 25 MHz to 225 MHz, TMDS data rate: 0.75 Gbps to 6.75 Gbps 30 bit Deep Color/CEC (HDMI connector only) x.v.Color/3D/ARC/HEC/HDR are not supported. Built-in cable EQ, EDID emulation Connector: 5 female HDMI Type A (19-pin), 2 female DVI-I (29-pin)	
		Universal Analog 2 inputs Switch-selectable between digital and analog Analog RGB : 0.7 V[p-p]/75 Ω HS/VS TTL level, CS TTL level Analog YPbPr : 1.0 V[p-p](Y)/0.7 V[p-p](Pb/Pr)/75 Ω EDID emulation Connector: 2 female DVI-I (29-pin)	
		Format	HDMI/DVI VGA to QWXGA (Dot clock: 25 MHz to 165 MHz) For WUXGA/QWXGA, only Reduced Blanking is supported. 480i / 480p / 576i / 576p / 720p / 1080i / 1080p
			Universal Analog VGA to QWXGA (Dot clock: 25 MHz to 165 MHz) For WUXGA/QWXGA, only Reduced Blanking is supported. 480i / 480p / 576i / 576p / 720p / 1080i / 1080p
	Audio	Digital 7 inputs Switch-selectable between digital and analog Multi-channel LPCM up to 8 channels Sampling frequency: 32 kHz to 192 kHz, Sample size: 16 bit to 24 bit Reference level: -20 dBFS, Max. input level: 0 dBFS Connector: 5 female HDMI Type A (19-pin), 2 female DVI-I (29-pin)	
		Analog 3 inputs Switch-selectable between digital and analog Unbalanced Stereo LR Input impedance: 24 kΩ Reference level: -10 dBu, Max. input level: +10 dBu Connector: 3 captive screw (3-pin)	
Output	Video	HDMI/DVI 1 output Video can be distributed to an HDMI/DVI output and an HDBaseT output simultaneously. HDMI/DVI 1.0 TMDS single link, HDCP 1.4 TMDS clock: 25.175 MHz to 202.5 MHz, TMDS data rate: 0.755 Gbps to 6.075 Gbps 30 bit Deep Color/CEC x.v.Color/3D/ARC/HEC/HDR are not supported. Built-in cable EQ Connector: 1 female HDMI Type A (19-pin)	
		HDBaseT 1 output Video can be distributed to an HDMI/DVI output and an HDBaseT output simultaneously. HDBaseT HDCP 1.4 30 bit Deep Color/CEC x.v.Color/3D/ARC/HEC/HDR are not supported. RS-232C/LAN Connector: 1 RJ-45 (*1) Cable: CAT.5E HDC, Cat5e UTP/STP, Cat6 UTP/STP (T568A/T568B straight-through)	
	Format VGA / XGA / WXGA (1280x768) / WXGA (1280x800) / Quad-VGA / SXGA / WXGA (1366x768) / WXGA (1366x768) / SXGA+ / WXGA+ / WXGA++ / UXGA / WSXGA+ / VESAHD / WUXGA / QWXGA For VESAHD/WUXGA/QWXGA, only Reduced Blanking is supported. 480p / 576p / 720p / 1080i / 1080p		
	Audio	Digital 1 x 2 outputs Audio can be distributed to an HDMI/DVI output and an HDBaseT output simultaneously. Multi-channel LPCM up to 8 channels Sampling frequency: 32 kHz to 192 kHz, Sample size: 16 bit to 24 bit Reference level: -20 dBFS, Max. output level: 0 dBFS Connector: 1 female HDMI Type A (19-pin), 1 RJ-45	
		Analog 1 output Unbalanced Stereo LR Output impedance: 50 Ω Reference level: -10 dBu, Max. output level: +10 dBu Connector: 1 captive screw (3-pin)	

## MSD-S Series User Guide

Item	Description	
Maximum transmission distances	Digital input	HDMI/DVI : 98 ft. (30 m) (*2)
	Digital output	HDMI/DVI : 164 ft. (50 m) (*2) HDBaseT : 328 ft. (100 m), 492 ft. (150 m) (Long reach mode is used) (*3)
Control	RS-232C	1 port/captive screw (3-pin)
	LAN	1 port/RJ-45 10Base-T/100Base-TX (Auto Negotiation), Auto MDI/MDI-X
	Contact closure	3 ports/captive screw (6-pin) Non-voltage contact input up to DC 24 V 1 A
	External control	RS-232C, LAN, HDBaseT, Contact closure, PLink (class1), CEC (Power control of sink device) (*4)
Functions	Video	Motion adaptive interlaced/progressive conversion, Aspect ratio control, Picture adjustment (brightness, contrast, image position, image size, etc.), Seamless Switching, Two video combinations: PinP and side-by-side, Pattern memory (5 settings), Each video output OFF, Bitmap display
	Audio	Input level offset control, Output level control, Lip Sync (Max. 70 ms.), Audio Downmix
	Others	WEB browser control, Automatic input channel switching, Audio breakaway for independent audio and video switching, Crosspoint memory (9 settings), Preset memory (8 settings), Last memory, Anti-Snow, Connection Reset (*5), External control commands (32 commands), Button security lockout, System check, HDBaseT status display, Standby switch
General	Power	100 - 240 VAC ±10%, 50 Hz/60 Hz ±3 Hz
	Power consumption	About 36 Watts
	Dimensions	16.9 (W) × 1.7 (H) × 11.8 (D)" (430 (W) × 44 (H) × 300 (D) mm) (1U high) (Excluding connectors and the like)
	Weight	9 lbs. (4.1 kg)
	Temperature	Operating : 32°F to 104°F (0°C to +40°C) Storage : -4°F to +176°F (-20°C to +80°C)
	Humidity	Operating/Storage: 20% to 90% (Non Condensing)

\*1 RJ-45 (HDBaseT connector) is only for extending digital video and audio signals over a Cat5e/Cat6 cable. Use it with IDK's HDBaseT Products. Do not use for LAN devices.

\*2 The maximum cable distance varies depending on the connected devices and was measured under following conditions:  
- 1080p@60. When IDK's 24 AWG cable was used and signals of 1080p@60 24 bit/pixel (8 bit/component) was input or output.

The maximum cable distance depends on the connected devices. The distance may not be extended with some device combinations, cabling method, or other manufacturer's cable. Video may be disturbed or may not be output even if signals are within the range mentioned above.

\*3 The maximum transmission distance was obtained when IDK's CAT.5E HDC cable was used. The distance may not be extended with some device combinations, cabling method, or other manufacturer's cable. Video may be disturbed or may not be output even if signals are within the range mentioned above.  
The maximum transmission distance is the shorter distance of connected HDBaseT product or sink device's maximum transmission distance.

\*4 Some sink devices cannot be controlled from the MSD-S through CEC.

\*5 For digital systems, some problems, such as an HDCP authentication error, can often be recovered by physically disconnecting and reconnecting the digital cables. However, the Connection Reset feature will fix these problems automatically without the need to physically plug and unplug the cables. It creates the same condition as if the cable were physically disconnected and reconnected. This feature only works for the MSD-S's output. If other devices are connected between the MSD-S's output and sink device, this feature may be invalid.

## 10.2.4 MSD-S72

Item		Description	
Input	Video	HDMI/DVI 7 inputs DVI connectors: Switch-selectable between digital and analog HDMI/DVI 1.0 TMDS single link, HDCP 1.4 TMDS clock: 25 MHz to 225 MHz, TMDS data rate: 0.75 Gbps to 6.75 Gbps 30 bit Deep Color/CEC (HDMI connector only) x.v.Color/3D/ARC/HEC/HDR are not supported. Built-in cable EQ, EDID emulation Connector: 5 female HDMI Type A (19-pin), 2 female DVI-I (29-pin)	
		Universal Analog 2 inputs Switch-selectable between digital and analog Analog RGB : 0.7 V[p-p]/75 Ω HS/VS TTL level, CS TTL level Analog YPbPr : 1.0 V[p-p](Y)/0.7 V[p-p](Pb/Pr)/75 Ω EDID emulation Connector: 2 female DVI-I (29-pin)	
		Format	HDMI/DVI VGA to QWXGA (Dot clock: 25 MHz to 165 MHz) For WUXGA/QWXGA, only Reduced Blanking is supported. 480i / 480p / 576i / 576p / 720p / 1080i / 1080p
			Universal Analog VGA to QWXGA (Dot clock: 25 MHz to 165 MHz) For WUXGA/QWXGA, only Reduced Blanking is supported. 480i / 480p / 576i / 576p / 720p / 1080i / 1080p
	Audio	Digital 7 inputs Switch-selectable between analog audio Multi-channel LPCM up to 8 channels Sampling frequency: 32 kHz to 192 kHz, Sample size: 16 bit to 24 bit Reference level: -20 dBFS, Max. input level: 0 dBFS Connector: 5 female HDMI Type A (19-pin), 2 female DVI-I (29-pin)	
		Analog 3 inputs Switch-selectable between digital audio Unbalanced Stereo LR Input impedance: 24 kΩ Reference level: -10 dBu, Max. input level: +10 dBu Connector: 3 captive screw (3-pin)	
Output	Video	HDMI/DVI 2 outputs Video can be distributed to HDMI/DVI outputs and HDBaseT outputs simultaneously. HDMI/DVI 1.0 TMDS single link, HDCP 1.4 TMDS clock: 25.175 MHz to 202.5 MHz, TMDS data rate: 0.755 Gbps to 6.075 Gbps 30 bit Deep Color/CEC x.v.Color/3D/ARC/HEC/HDR are not supported. Built-in cable EQ Connector: 2 female HDMI Type A (19-pin)	
		HDBaseT 2 outputs Video can be distributed to HDMI/DVI outputs and HDBaseT outputs simultaneously. HDBaseT HDCP 1.4 30 bit Deep Color/CEC x.v.Color/3D/ARC/HEC/HDR are not supported. RS-232C/LAN Connector: 2 RJ-45 (*1) Cable: CAT.5E HDC, Cat5e UTP/STP, Cat6 UTP/STP (T568A/T568B straight-through)	
		Format VGA / XGA / WXGA (1280x768) / WXGA (1280x800) / Quad-VGA / SXGA / WXGA (1366x768) / WXGA (1366x768) / SXGA+ / WXGA+ / WXGA++ / UXGA / WSXGA+ / VESAHD / WUXGA / QWXGA For VESAHD/WUXGA/QWXGA, only Reduced Blanking is supported. 480p / 576p / 720p / 1080i / 1080p	
	Audio	Digital 2 x 2 outputs Audio can be distributed to HDMI/DVI outputs and HDBaseT outputs simultaneously. Multi-channel LPCM up to 8 channels Sampling frequency: 32 kHz to 192 kHz, Sample size: 16 bit to 24 bit Reference level: -20 dBFS, Max. output level: 0 dBFS Connector: 2 female HDMI Type A (19-pin), 2 RJ-45	
		Analog 2 output Unbalanced Stereo LR Output impedance: 50 Ω Reference level: -10 dBu, Max. output level: +10 dBu Connector: 2 captive screw (3-pin)	

## MSD-S Series User Guide

Item	Description	
Maximum transmission distances	Digital input	HDMI/DVI : 98 ft. (30 m) (*2)
	Digital output	HDMI/DVI : 164 ft. (50 m) (*2) HDBaseT : 328 ft. (100 m), 492 ft. (150 m) (Long reach mode is used) (*3)
Control	RS-232C	1 port/captive screw (3-pin)
	LAN	1 port/RJ-45 10Base-T/100Base-TX (Auto Negotiation), Auto MDI/MDI-X
	Contact closure	3 ports/captive screw (6-pin) Non-voltage contact input up to DC 24 V 1 A
	External control	RS-232C, LAN, HDBaseT, Contact closure, PLink (class1), CEC (Power control of sink device) (*4)
Functions	Video	Motion adaptive interlaced/progressive conversion, Aspect ratio control, Picture adjustment (brightness, contrast, image position, image size, etc.), Seamless Switching, Two video combinations: PinP and side-by-side, Pattern memory (5 settings), Each video output OFF, Bitmap display
	Audio	Input level offset control, Output level control, Lip Sync (Max. 70 ms.), Audio Downmix
	Others	WEB browser control, Automatic input channel switching, Audio breakaway for independent audio and video switching, Crosspoint memory (9 settings), Preset memory (8 settings), Last memory, Anti-Snow, Connection Reset (*5), External control commands (32 commands), Button security lockout, System check, HDBaseT status display, Standby switch
General	Power	100 - 240 VAC ±10%, 50 Hz/60 Hz ±3 Hz
	Power consumption	About 48 Watts
	Dimensions	16.9 (W) × 1.7 (H) × 11.8 (D)" (430 (W) × 44 (H) × 300 (D) mm) (1U high) (Excluding connectors and the like)
	Weight	9 lbs. (4.1 kg)
	Temperature	Operating : 32°F to 104°F (0°C to +40°C) Storage : -4°F to +176°F (-20°C to +80°C)
	Humidity	Operating/Storage: 20% to 90% (Non Condensing)

\*1 RJ-45 (HDBaseT connector) is only for extending digital video and audio signals over a Cat5e/Cat6 cable. Use it with IDK's HDBaseT Products. Do not use for LAN devices.

\*2 The maximum cable distance varies depending on the connected devices and was measured under following conditions:  
- 1080p@60. When IDK's 24 AWG cable was used and signals of 1080p@60 24 bit/pixel (8 bit/component) was input or output.

The maximum cable distance depends on the connected devices. The distance may not be extended with some device combinations, cabling method, or other manufacturer's cable. Video may be disturbed or may not be output even if signals are within the range mentioned above.

\*3 The maximum transmission distance was obtained when IDK's CAT.5E HDC cable was used. The distance may not be extended with some device combinations, cabling method, or other manufacturer's cable. Video may be disturbed or may not be output even if signals are within the range mentioned above.  
The maximum transmission distance is the shorter distance of connected HDBaseT product or sink device's maximum transmission distance.

\*4 Some sink devices cannot be controlled from the MSD-S through CEC.

\*5 For digital systems, some problems, such as an HDCP authentication error, can often be recovered by physically disconnecting and reconnecting the digital cables. However, the Connection Reset feature will fix these problems automatically without the need to physically plug and unplug the cables. It creates the same condition as if the cable were physically disconnected and reconnected. This feature only works for the MSD-S's output. If other devices are connected between the MSD-S's output and sink device, this feature may be invalid.



Problem	Cause/Check item/Solution	Page
Video is not being output.	<ul style="list-style-type: none"> <li>• Error code A: Set <b>"8.2.2 Selecting input channels"</b> to a value other than "OFF".</li> <li>• If no error code is displayed: Set <b>"9.3.7 Test pattern"</b> to any pattern (other than "OFF"). <ul style="list-style-type: none"> <li>- If none of the test patterns can be successfully presented on the sink device, check [6] to [8].</li> <li>- If a test pattern is presented on the sink device, the source device may not be providing a signal.</li> </ul> </li> </ul>	—
Digital input video is not being output.	[1] The time setting for monitoring no-signal input may be too short.	73
	[2] Change the input equalizer setting.	75
Video is not output from DVI input connector.	[3] Check the signal type.	73
Analog input video is not being output.	[4] Change the input signal type.	75
Video is not being output.	[5] If the source device has multiple output connectors, check the video output settings for the affected port of the source device.	—
Video has disappeared, is intermittent, or presents noise.	[6] If using a long cable for input or output, replace it with a 16 ft. (5 m) or shorter cable. Since the MSD-S has automatic cable length equalization, long cables can be successfully used, but the MSD-S's full performance may not be realized if the cable or connected peripheral devices are of inferior quality. If the error is solved by replacing the cable, the signal may have been degraded due to excessive attenuation or crosstalk. IDK offers high-quality cables, cable boosters and extenders. Please contact us as needed.	—
	[7] When high-speed signals (high resolution: such as UXGA, WUXGA, QWXGA, 1080p; DEEP COLOR signal) are presented to the input or provided by the output, video may not be displayed or noise may appear. This is largely dependent on cable quality and the characteristics of connected peripheral devices. If the problem occurs only when a specific input is selected, the problem is being caused by difficulties ahead of that input port. If it occurs for all inputs or when an internal MSD-S test pattern is displayed, the problem is related to the output side of the system. One possible solution is to change to a lower resolution format and/or disable Deep color. You can check the resolution and color depth of the input signal in <b>"9.21.3 Input signal status"</b> and you can also limit resolution and color depth of input signal as defined by the MSD-S's EDID configuration settings.  You can specify the output resolution and check the color depth of the output signal in <b>"9.21.1 Sink device status"</b> . It is also possible to limit the output signal color depth.	54, 65  101, 104

Problem	Cause/Check item/Solution	Page
Input video and test pattern are not output.	[8] If you set the output resolution to other than "AUTO", check if the selected resolution is supported by the sink device. As an example, if you select "1080i", video may not be presented by sink devices that do not support interlaced signals. For TV output resolutions (720p to 1080p), check the vertical synchronous frequency. PC output resolutions (VGA to QWXGA) may not be compatible with LCD TVs.	54
Video is intermittent.	If you set " <b>9.6.6 Automatic detection of video input interruption</b> " to "ON", false detection may occur. Change the setting to "OFF".	76
Video from HDMI output is interrupted or has noise.	If the problem occurs in all input channels or when a test pattern is displayed, replace the output cable with a shorter one or of higher quality.	—
Video from analog input is displayed in black-and-white or green.	Change the input signal type.	75
The left, right, top and bottom sides are cut off.	If the problem occurs only when "CROSS HATCH" (internal test pattern) is output, the sink device is enlarging the video. Adjust the sink device.	60
	If the sink device does not provide image configuration adjustments, set the video size and position parameters for the MSD-S's output port. If the problem occurs even if "CROSS HATCH" is output to all outputs, check [9] to [14].	54
Part of video is cut off or black is displayed at edge(s).	[9] Check the overscan setting.	69
	[10] Settings of the image position or size are not changed? <b>Note:</b> Image position and size can be set for each input or output.	70, 70 56, 57
	[11] If aspect ratios of the input signal and output resolution do not match, video may be cut off automatically or black may be displayed at edge(s) depending on settings. If the video is displayed on the full screen by setting the aspect ratio to "FULL", there is no problem. If the aspect ratios are not the same, you can select a) or b) below: a) Video is cut off. b) Black is displayed at edge(s).	68 69

Problem	Cause/Check item/Solution	Page
Part of video is cut off or black is displayed at edge(s). (Cont'd)	[12] If " <b>9.21.3 Input signal status</b> " is set to "AUTO SETUP ON", input timing is measured when new signal is input. However, if a non-standard video format is applied to the input, the measurement may fail to provide optimal results. In this case and if the video is cut off, but the vertical and horizontal frequencies are correctly presented on the MSD-S's front panel display " <b>9.7.8 Automatic setting of input timing</b> ", the signal's characteristics don't match the built in format parameters. It will be necessary to make manual adjustments. Once the manual adjustments are configured, their values will automatically be stored for that non-standard source on that input port.	80 87
	[13] For analog input, set the automatic measurement of input timing in " <b>9.7.1 Automatic measurement</b> ". If the result of the automatic measurement shows that video is cut off or black is displayed at edges, set the total number of horizontal pixels, scanning start position, and the active area. For digital input, the start position and active area do not have to be set. Only when video edges are cut off 1 to 2 dots, set these items. (For digital input, the total number of horizontal pixels cannot be set).	83 to 84
Black is displayed at top, bottom, right and left on PC video or only part of the PC video is displayed, and the rest can be revealed by scrolling with the mouse.	[14] Does the PC resolution (you can check it in "Properties" of the PC) match the resolution that is output from the PC (you can check it in " <b>9.21.3 Input signal status</b> "). If not, set the EDID and PC resolutions. For laptops, if the "copydesktop" is enabled, the output to an external monitor is limited to the resolution of the laptop's native LCD screen. As a result, black may be displayed at edges. The problem can be solved by enlarging the display, extending the desktop or displaying only to the external monitor.	100, 101
Video is reduced vertically or horizontally.	Does the selected aspect ratio of the output resolution match that of the connected sink device? If not, adjust the aspect ratio of the sink device.	55
	Check the set aspect ratio of the input signal.	68
	Check the monitor setting of the source device (such as 4:3, 16:9, letter box and the like).	—
	For analog inputs, signals that cannot be recognized by the MSD-S may possibly be output with the wrong aspect ratio. Perform the automatic measurement in the "NEXT ASPECT" mode.	80
Video flickers	If an interlace signal is input to a sink device that does not support interlace inputs, the video may flicker. Check the format settings for the MSD-S's output port driving the sink device.	54
PC's dual monitor cannot be set or the setting is canceled.	If the monitoring function for no-signal input is enabled, the dual monitor function of your PC may not work correctly. In this case, disable the monitoring function.	73
It takes a long time to output video after video input is switched.	If you set the HDCP output to "HDCP INPUT ONLY", some sink devices may fail HDCP authentication. In this case, the sink may temporarily stop presenting video and audio when switching between input signals with and without HDCP support. In this case, set the HDCP output setting to "ALWAYS".	63

Problem	Cause/Check item/Solution	Page
Analog video input from a PC displays with light-and-dark vertical stripes.	Set the total number of horizontal pixels. If you change the total number of horizontal pixels, you may sometimes have to set the start position of scanning and the active area.	83
Analog video input from a PC displays with light shadows on a few video lines.	Adjust the input tracking setting.	87
Fluctuation appears on the analog input video.	Adjust the input tracking setting.	87
Automatic measurement of input timing fails.	In order to execute the automatic measurement of the input timing, the input video must have 25% or more brightness and its edges (all sides) need to be in contact with the circumscribed rectangle in the effective display area.	80
Image position of analog input video changes unexpectedly.	If the function that automatically adjusts the image position (upper left of the screen) works while the automatic measurement is executed, the video may move on its own. In this case, disable the automatic measurement of start position function.	85
Part of the bitmap is cut off, or bitmap is not displayed on the full screen.	Set the total number of horizontal dots. If you change the total number of horizontal dots, you may sometimes need to set the start position of scanning and the active area manually.	137 138
● Audio output		
Audio is not being output.	If audio is not being output, first check the error code in " <b>9.21.1 Sink device status</b> ". (The MSD-S has multiple output connectors. Find the error code of the output connector that is not outputting audio.) <ul style="list-style-type: none"> <li>• Error code 1: Set "<b>9.10.3 Audio mute</b>" to "OFF".</li> <li>• Error code 2: Ensure that the source device is connected and powered on.</li> <li>• Error code 3: Signal is not input. Check [15], [16], [18] and [19].</li> <li>• Error code 4: There may be problems in the source device side or HDCP authentication. Check [15].</li> <li>• Error code 5: If the display device or AV amplifier does not support HDCP, only signals without content protection (such as analog sources) will be output; audio is not output when signal with content protection is applied to input. Some HDMI/DVI source devices check if the connected device is HDCP compliant and determines whether to output an HDCP encrypted signal or not. Since the MSD-S is HDCP compliant, audio may not be output if the MSD-S is connected to a sink device or AV amplifier that does not support HDCP. In this case, disable HDCP input for the port supporting the source device. "<b>9.6.3 HDCP input</b>".</li> <li>• Error code 6: There are problems in the source device.</li> </ul>	—

Problem	Cause/Check item/Solution	Page
Audio is not being output. (Cont'd)	<ul style="list-style-type: none"> <li>• Error code 7: LCD monitors may not output compressed audio, such as Dolby Digital, DTS, and so on. If playing content with compressed audio (such as Blu-ray disc), check the audio output setting. The audio signal parameters terminating from the source device can be controlled by changing the EDID settings for input port(s).</li> <li>• Error code 8: Set <b>"9.10.1 Output audio"</b> to "ON".</li> <li>• Error code 9: Set <b>"9.4.7 Output format"</b> to a mode other than "DVI MODE". If the sink device does not support HDMI signals, the MSD-S outputs DVI automatically. Check which signal type is supported by the sink device.</li> <li>• Error code A: Set <b>"8.2.2 Selecting input channels"</b> to "OFF".</li> <li>• If any error code is not displayed: Check [15] to [19]. The source device may not be outputting audio.</li> </ul>	—
Audio is not output from digital input.	[15] Is video being output correctly? If not, check [1], [2], [3], [5] [6] and [7].	—
	[16] Is DVI signal output from the source device? You can check the input signal type in <b>"9.21.3 Input signal status"</b> . DVI signal may be output automatically depending on EDID settings.	100
	[17] Is the input audio format supported by the connected sink device or AV amplifier input? Typically, LCD monitors may not support 88.2 kHz or higher sampling frequency of LPCM and compressed audio (such as Dolby Digital, DTS, and other format). The source device's audio signal characteristics can be managed by the MSD-S's EDID configuration settings.	104
Audio is not output.	[18] Is the selection of digital audio input and analog audio input correct?	99
	[19] If the source device has multiple output connectors, check the audio output settings for the specific port of that device.	—
Audio is output from digital output connectors but not from analog output connectors.	If compressed audio (such as Dolby Digital, DTS, and other formats) is applied to the input, analog audio is not provided at output. You can check the input audio type in <b>"9.21.3 Input signal status"</b> .	99
Audio is output from analog output connectors but not from digital output connectors.	If the output resolution is set to a value other than "AUTO", make sure that the sink device or AV amplifier supports the selected output resolution. If a PC output resolution (VGA to QWXGA) is selected, some sink devices and AV amplifiers cannot output audio.	54
	If the sampling frequency is set to a value other than "AUTO", make sure that the sampling frequency is supported by the sink device or AV amplifier. Some LCD monitors may not output audio if the sampling frequency is high (typically 88.2 kHz or higher).	96

Problem	Cause/Check item/Solution	Page
Compressed audio (such as Dolby Digital, DTS) is not output from the source device.	Compressed audio input is set to OFF (EDID settings) by factory default. If using compressed audio, change the EDID setting.	104 to 107
	In order to output multi-channel compressed audio, configure the MSD-S's EDID profile to define the correct number of speakers.	108
	Check the audio output settings of the source device.	—
Multi-channel audio is not output.	In order to output multi-channel audio, configure the MSD-S's EDID profile to define the correct number of speakers.	108
Audio only from specific scenes is not output from digital input.	Is "DOWNMIX" is set for multi-channel audio output? For multi-channel audio content, channel assignments are dynamic and can change between scenes. Audio may not be output if audio is not included in the selected channel.	97
<b>• Button operation</b>		
Buttons do not operate.	Ensure that buttons are not locked.	37
	When a control command is executed using a front panel button, all buttons are disabled until the command is executed or INVALID TIME passes.	127
	Check the setting of function buttons press dwelling time. This feature prevents accidental operation.	150
	Immediately after powered on, all buttons are disabled until the connection of the sink device is confirmed.	31
	Function buttons do not work by factory default, since no control command is registered.	128 114
Setting changes are not saved or observed to be active in actual operation.	Settings within certain configuration menus may not be saved unless the "MENU/ENTER" button is pressed after making the setting selection.	32
<b>• Communication command control</b>		
Control commands cannot be issued from PC to the MSD-S.	Are the following items set correctly?	
	For RS-232C : Baud rate and data word length	110
	For LAN : IP address and subnet mask	111
	Is COM PORT's FUNCTION set to "RECEIVER" mode?	110
	If this feature is set to "TRANSMITTER" mode, the MSD-S cannot be controlled externally.	113
"@ERR,6" is returned.	When remote commands are issued, additional commands will not be processed until the current commands are executed or until the INVALID TIME period elapses.	127
	Immediately following powered on, the remote command feature is disabled until connection with sink device is confirmed.	—

Problem	Cause/Check item/Solution	Page
<b>• Sending control command function</b>		
Control command is not sent.	Ensure that the registered control command data and the number of bytes are both correct. Devices requiring delimiters may not execute commands correctly if the delimiters are not sent. If the set number of bytes is not correct, the control command may not be sent completely or unnecessary data may follow the control command.	116
	Is the registered control command correctly linked to the desired control command execution condition?	124
	Is COM PORT's FUNCTION set to "TRANSMITTER" mode? In order to send control commands, the communication port must be configured for "TRANSMITTER" mode. If using LAN, set the IP address and other com port settings of the connected device.	110 113
"RETRY OVER ERROR" is displayed and control command is not sent completely.	Is the registered reply command correct?	121
	Ensure that the setting of "TIME OUT" for checking control commands is not too short.	116
Control through CEC cannot be performed.	Does the cable support CEC? In order to use CEC, use an HDMI cable that supports CEC.	—
	Does the sink device support CEC? Is the HDMI link function of the sink device set to be enabled? Enable the HDMI link control of the sink device and the function which powers on the sink device from external devices of the sink device.	—
<b>• Others</b>		
Input signal temporarily disappear when input channel is switched.	When the CEC connection changes, EDID may also change. In this case, the input signal may be interrupted. Check the CEC connection settings.	67
Devices cannot be controlled through CEC.	Are HDMI cables that support CEC being used?	67
	To use CEC, enable the HDMI link control of the connected devices (such as LCD TVs, Blu-ray recorder, and other formats).	67

If additional assistance is required, please perform the following tests and then contact us.

No.	Checking items	Result
1	The problem occurs at all connectors?	Yes or No
2	Connect the devices using genuine cables without connecting the MSD-S. The problem still cannot be solved? Please contact us for assistance.	Yes or No

---

---

User Guide of MSD-S Series

Ver. 1.7.0

Issued on: 2 December 2024

---

---



**Headquarters**

IDK Corporation  
7-9-1 Chuo, Yamato-shi, Kanagawa-pref.  
242-0021 JAPAN  
TEL: +81-46-200-0764 FAX: +81-46-200-0765

Email: [idk\\_eng@idk.co.jp](mailto:idk_eng@idk.co.jp)

URL: [www.idkav.com](http://www.idkav.com)

**USA**

IDK America Inc.  
72 Grays Bridge Road Suite 1-C, Brookfield, CT 06804  
TEL: +1-203-204-2445

Email: [sales@idkav.com](mailto:sales@idkav.com)

URL: [www.idkav.com](http://www.idkav.com)

**Europe**

IDK Europe GmbH  
Lise-Meitner-Str. 6, D-40878 Ratingen  
TEL: +49-2102-578-301-0

Email: [info@idkav.eu](mailto:info@idkav.eu)

URL: [www.idkav.com](http://www.idkav.com)



**Product information  
Support**

Arvanics Corporation  
7-9-1 Chuo, Yamato-shi, Kanagawa-pref.  
242-0021 JAPAN  
TEL: +81-46-259-6920 FAX: +81-46-259-6930

Email: [info@arvanics.com](mailto:info@arvanics.com)

URL: [www.arvanics.com](http://www.arvanics.com)

Information in this document is subject to change without notice.

©2021 IDK Corporation, all rights reserved. All trademarks mentioned are the property of their respective owners.