

HDMI/USB-C Encoder/Decoder

NJR-L21UC-T/NJR-L31UC-R

Command Guide

Ver.2.0.0

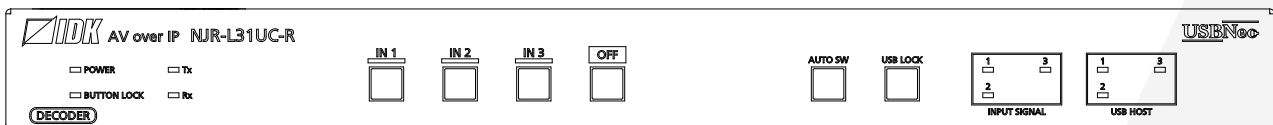
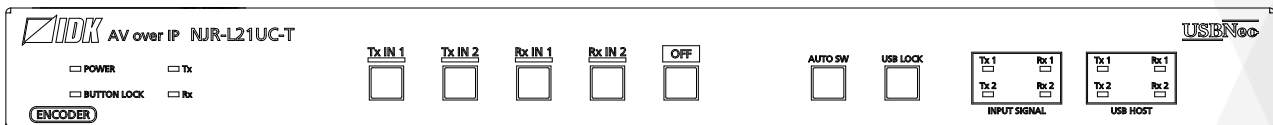

Thank you for choosing our product.

To ensure the best performance of this product, please read this user guide fully and carefully before using it and keep this manual together with the product for future reference as needed.

- All rights reserved.
- Some information contained in this guide such as exact product appearance, communication commands, and so on may differ depending on the product version.
- This guide is subject to change without notice. You can download the latest version from IDK’s website at: www.idkav.com

About technical documentation

■ **Please read the following guides before connecting this equipment to a power source.**

<p>1. Safety Instructions Contains important safety instructions for the product to help ensure your own personal safety and protect the product and working environment from potential damage.</p>	<p>Provided with the product.</p>
<p>2. Setup Guide Contains setup information and precautions for installing the product and connecting cables.</p>	<p>Download from www.idkav.com</p>

■ **Please refer to the following guides as needed.**

<p>3. Operation Guide Describes how to configure and use the equipment.</p>	<p>Download from www.idkav.com</p>
<p>4. User Guide Contains detailed explanation of functions, setting values, and restrictions.</p>	
<p>5. Command Guide Contains information on controlling the equipment using communication commands through RS-232C or LAN communication.</p>	

Trademarks

- HDBaseT™ and the HDBaseT Alliance Logo are trademarks of the HDBaseT Alliance.
- The terms HDMI and HDMI High-Definition Multimedia Interface, and the HDMI Logo are trademarks or registered trademarks of HDMI Licensing Administrator, Inc. in the United States and other countries.
- SDVoE™ and SDVoE logo are trademarks of SDVoE Alliance.
- All other company and product names mentioned in this document are either registered trademarks or trademarks of their respective owners. In this document, the “®” or “™” marks may not be specified.
- ©2025 IDK Corporation, all rights reserved.

FCC STATEMENT

Note: This equipment has been tested and found to comply with the limits for a Class A digital device, pursuant to part 15 of the FCC Rules. These limits are designed to provide reasonable protection against harmful interference when the equipment is operated in a commercial environment. This equipment generates, uses, and can radiate radio frequency energy and, if not installed and used in accordance with the instruction manual, may cause harmful interference to radio communications. Operation of this equipment in a residential area is likely to cause harmful interference, in which case the user will be required to correct the interference at his own expense.

(Class A)

**Supplier's Declaration of Conformity
47 CFR § 2.1077 Compliance Information**

Unique Identifier

Type of Equipment: HDMI/USB-C Encoder/Decoder

Model Name: NJR-L21UC-T, NJR-L31UC-R

Responsible Party – U.S. Contact Information

Company Name: IDK America Inc.

Address: 72 Grays Bridge Road Suite 1-C, Brookfield, CT 06804

Telephone number: +1-203-204-2445

URL: www.idkav.com

FCC Compliance Statement

This device complies with Part 15 of the FCC Rules. Operation is subject to the following two conditions: (1) This device may not cause harmful interference, and (2) this device must accept any interference received, including interference that may cause undesired operation.

(FCC SDoC)

CE MARKING

This equipment complies with the essential requirements of the relevant European health, safety and environmental protection legislation.

WEEE MARKING



Waste Electrical and Electronic Equipment (WEEE), Directive 2002/96/EC
(This directive is only valid in the EU.)

This equipment complies with the WEEE Directive (2002/96/EC) marking requirement.

The left marking indicates that you must not discard this electrical/electronic equipment in domestic household waste.

Contents

About this Guide	5
Command and Response	5
Command format	5
Response example.....	5
RS-232C communication	6
RS-232C transmission mode	6
RS-232C communication specification.....	6
Connecting RS-232C cable	6
Virtual COM port.....	6
LAN communication	7
LAN communication specification	7
LAN connector specification	7
The number of TCP-IP connections	7
LAN to RS-232C conversion	8
Command list	9
Details of commands	11
Error status	11
Input/Output channel selection	12
Output.....	13
Input 15	
Input channel automatic switching	15
Output audio.....	18
EDID 18	
RS-232C setting.....	20
LAN 22	
Configuring NJR-L	25
Status	27
Unsolicited status notification.....	32

About this Guide

This guide contains the procedure for controlling NJR-L using commands via RS-232C or LAN communication.

Command and Response

Setting command : For setting or changing commands

Getting command : For getting the current settings or statuses

Command format

A command consists of [**@**] (**40** in hex), 3 one-byte alphabetical characters (Not case sensitive), and parameters. [,] (a comma, **2C** in hex) is indicated between two characters.

The number of parameters varies depending on commands.

Processing is executed by sending line endings <CR><LF> (return+line feed, **0D** and **0A** in hex) at the end of the command. The line endings are added to each response.

@SPM,2<CR><LF> in hex:

	Header	3 one-byte alphabetical characters			Comma	Parameter	Line endings	
ASCII	@	S	P	M	,	2	CR	LF
Hex	40	53	50	4D	2C	32	0D	0A

Response example

If the command is valid and performed,

Setting: the same command string is returned.

Command example → @SSW,1,1<CR><LF>

Response example ← @SSW,1,1<CR><LF>

Getting: the current settings are returned in ascending order following the sent command.

Command example → @GSW,1<CR><LF>

Response example ← @GSW,1,1,1<CR><LF>

Error response:

If the command is invalid, an error response ("**@ERR (P.10)**") is returned.

Command example → @XXX<CR><LF>

Response example ← @ERR,2<CR><LF>

RS-232C communication

It takes about 7 seconds at maximum to be ready for normal operation after powering up.

RS-232C transmission mode

Set this setting to [ON] to control the NJR-L using RS-232C communication.



Item	RS-232C transmission mode
Value	DIP switch No.1 OFF, ON

[OFF] : Transmits signals to the connected RS-232C connector via a cable for extension.

[ON] : Controls the NJR-L from an external device.

RS-232C communication specification

Compliant standard	RS-232C
Baud rate	4800/9600/14400/19200/38400/57600/115200 (bps)
Data bit length	7/8 (bit)
Parity check	NONE, ODD, EVEN
Stop bit	1/2 (bit)
X parameter	Invalid
Flow control	None
Delimiter	CR LF (Carriage return and line feed, 0D and 0A in hex)
Communication method	Full duplex

Connecting RS-232C cable

Insert and secure the wires from the RS-232C cable into the supplied 3-pin captive screw connector, and then insert the captive screw connector into the mating connector on the NJR-L.

24 AWG to 16 AWG conductor gauge is recommended. The recommended wire strip length is 0.28 in. (7 mm). Short RTS/CTS and DTR/DSR as needed.



Virtual COM port

RS-232C communication is available in the USB connectors of IN1 (UBS-C) or IN2(USB-B). Either IN1 or IN2 can be used as a virtual COM port. Set the channel to be used via the Web browser or @GRP/@SRP.

LAN communication

It takes about 50 seconds at maximum to be ready for normal operation after powering up.

LAN communication specification

Physical layer	10Base-T (IEEE802.3i)/100Base-TX (IEEE802.3u)
Network layer	ARP/IP/ICMP
Transport layer	TCP Port used for command control: 1100 UDP Port used for unsolicited notice: 1 to 65535
Maximum number of connections	8

LAN connector specification

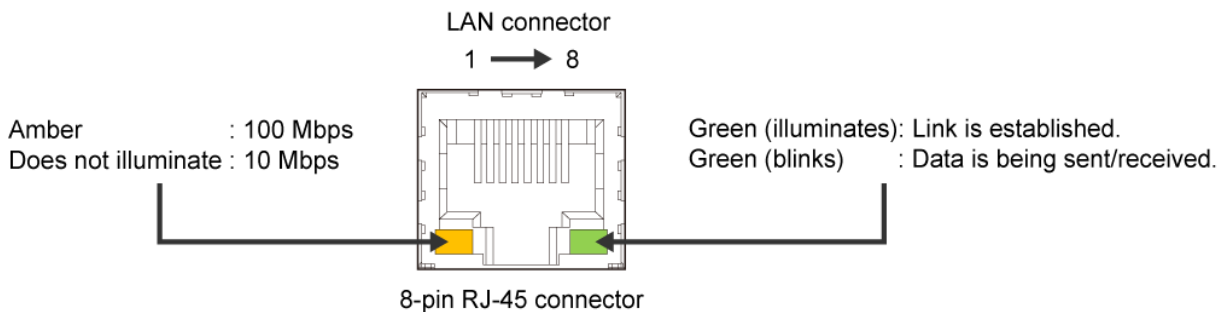

Auto MDI/MDI-X that distinguishes and switches straight/cross cables automatically is supported.

The number of TCP-IP connections

The NJR-L supports up to eight simultaneous TCP-IP connections (Eight logical ports).

To maintain optimal system accessibility, it is advisable to issue **port-open** and **port-close** commands before and after command or query strings are issued. This approach enables eight or more control devices to be effectively interfaced simultaneously and without concern for communication errors.

As a safeguard, the NJR-L incorporates a timeout window for each port. If any port is inactive for more than 30 seconds (by default), it will be closed automatically.

You can change the timeout setting using IP-NINJAR Configurator, NJR-CTB, or “@GLD/@SLD (P.29)”.

LAN to RS-232C conversion

Data received via LAN communication can be transmitted to the connected RS-232C connector over an extension cable.

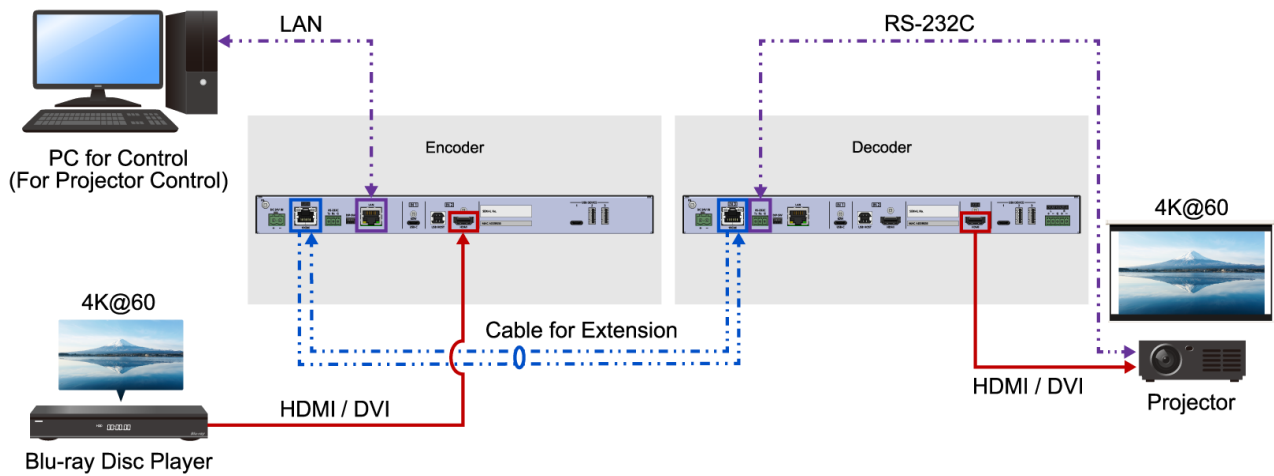

If “@G-T/@S-T LAN RS-232C (P.24)” is set to [CONVERT], the data received via LAN communication is output to the RS-232C connector.

Settings need to be set for each LAN connection.

To enable the LAN RS-232C conversion function, set the DIP switch No.1 “RS-232C transmission mode (P.6)” to [ON] (controlling the NJR-L from an external device).

Command list

■ Error status

@ERR	Error status	11
------	--------------	----

■ Input/Output channel selection

@GCN/@SCN	Video/USB host channel switching	12
-----------	----------------------------------	----

■ Output

@GVO/@SVO	Signal output	13
@GDB/@SDB	Video mute	13
@GEN/@SEN	HDCP authentication	14
@HAU	HDCP re-encryption	14

■ Input

@GHE/@SHE	HDCP	15
-----------	------	----

■ Input channel automatic switching

@GUU/@SUU	Automatic switching	15
@GAU/@SAU	Signal ON priority	16
@GOF/@SOF	Signal OFF priority	17

■ Output audio

@GAM/@SAM	Mute	18
-----------	------	----

■ EDID

@GED/@SED	EDID selection	18
@GVF/@SVF	Resolution	19

■ RS-232C

@GCT/@SCT	Command setting	20
@GRP/@SRP	Input channel selection	21

■ LAN

@GIP/@SIP	Network	22
@GMC	MAC address	23
@GLD/@SLD	Automatic disconnection time (timeout)	23
@G-T/@S-T	LAN RS-232C conversion	24

■ Configuring NJR-L

@GPD/@SPD	USB-C power delivery	25
@GUF/@SUF	USB-C function	25
@GUL/@SUL	USB host lock	26
@RBT	Reboot	26
@CLR	Initialization	26

■ **Status**

@GSS	Input signal/Output signal status	27
@GES	Viewing sink device EDID	30
@GHC	System check	31
@GIV	Device information	31

■ **Unsolicited status notification**

@GDA/@SDA	IP address/UDP port number of destination	33
@GPH/@SPH	Notification interval	34
@PSH	Unsolicited status notification	35
@AIN	Input signal status (For each connector)	36
@AOT	Output signal status (For each channel)	38
@GAA	Alarm status	40

Details of commands

Default values are shaded.

Optional descriptions are indicated in parentheses.

Error status

@ERR	Error status
Response	@ERR,error<CR><LF>
error: Error status 1 = Erroneous format or value 2 = Undefined command or wrong format 3 = The command could not be executed.	
Setting example	
@SED<CR><LF>	Selecting EDID
@ERR,1<CR><LF>	Command format or parameter was invalid.

Input/Output channel selection

@GCN/@SCN		Video/USB host channel switching
Getting	Command	@GCN,device,ch,port,tr <CR><LF>
	Response	@GCN,device,ch,port,tr,video,usb<CR><LF>
Setting	Command	@SCN,device,ch,port,tr,input<CR><LF>
device: 1 = NJR-L21UC-T 2 = NJR-L31UC-R		
ch: Channel 1 (Fixed)		
port: 1 (Fixed)		
tr: Target device 1 = NJR-L21UC-T 2 = NJR-L31UC-R		
video : Video input channel usb : USB host channel 0 = INOFF 1 to 3 = IN1 to IN3		
input: Input channel 0 = INOFF 1 to 3 = IN1 to IN3		
Getting example		
@GCN,1,1,1,1,1<CR><LF> @GCN,1,1,1,1,1,2<CR><LF>		Getting the input channel selection of the NJR-L21UC-T. Video input channel : IN1 USB host channel : IN2
Setting example		
@SCN,1,1,1,1,1,1<CR><LF>		Setting the input channel of the NJR-L21UC-T to IN1.

Output

@GVO/@SVO		Signal output
Getting	Command	@GVO,device,ch,port<CR><LF>
	Response	@GVO,device,ch,port,signal<CR><LF>
Setting	Command	@SVO,device,ch,port,signal<CR><LF>
device: 1 = NJR-L21UC-T 2 = NJR-L31UC-R		
ch: Channel 1 (Fixed)		
port: 1 (Fixed)		
signal: Video signal output 0 = OFF 1 = ON		
Getting example		
@GVO,1,1,1<CR><LF>		Getting the signal output
@GVO,1,1,1,1<CR><LF>		ON
Setting example		
@SVO,1,1,1,0<CR><LF>		Setting the signal output to OFF

@GDB/@SDB		Video mute
Getting	Command	@GDB,device,ch,port<CR><LF>
	Response	@GDB,device,ch,port <CR><LF>
Setting	Command	@SDB,device,ch,port,mute<CR><LF>
device: 1 = NJR-L21UC-T 2 = NJR-L31UC-R		
ch: Channel 1 (Fixed)		
port: 1 (Fixed)		
mute: Video mute 0 = OFF 1 = ON		
Getting example		
@GDB,1,1,1<CR><LF>		Getting the video mute
@GDB,1,1,1,1<CR><LF>		ON
Setting example		
@SDB,1,1,1,1<CR><LF>		Setting the video mute to ON

@GEN/@SEN		HDCP authentication
Getting	Command	@GEN,device,ch,port<CR><LF>
	Response	@GEN,device,ch,port,hdcpcr<CR><LF>
Setting	Command	@SEN,device,ch,port,hdcpcr<CR><LF>
device: 2 (Fixed)		
ch: Channel 1 (Fixed)		
port: 1 (Fixed)		
hdcpcr: HDCP authentication 1 = ALWAYS 2 = HDCP INPUT ONLY 3 = HDCP2.2		
Getting example		
@GEN,2,1,1<CR><LF>		Getting the OUT1 HDCP authentication
@GEN,2,1,1,2<CR><LF>		HDCP INPUT ONLY
Setting example		
@SEN,2,1,1,1<CR><LF>		Setting OUT1 HDCP authentication to ALWAYS
Remarks: For NJR-L31UC-R only		

@HAU		HDCP re-encryption
Setting	Command	@HAU,device,ch,port <CR><LF>
device: 2 (Fixed)		
ch: Channel 1 (Fixed)		
port: 1 (Fixed)		
Setting example		
@HAU,2,1,1<CR><LF>		Executing re-encrypt HDCP
Remarks: For NJR-L31UC-R only		

Input

@GHE/@SHE		HDCP input
Getting	Command	@GHE,device,ch,port<CR><LF>
	Response	@GHE,device,ch,port,hdcp<CR><LF>
Setting	Command	@SHE,device,ch,port,hdcp<CR><LF>
device: 1 = NJR-L21UC-T 2 = NJR-L31UC-R		
ch: Channel 1 (Fixed)		
port: 1 = IN1 2 = IN2		
hdcp: HDCP input 0 = NOT SUPPORT 1 = HDCP 2.2 SUPPORT 2 = HDCP 1.4 SUPPORT		
Getting example		
@GHE,1,1,1<CR><LF>		Getting the IN1 HDCP input
@GHE,1,1,1,0<CR><LF>		NOT SUPPORT
Setting example		
@SHE,1,1,1,1<CR><LF>		Setting the IN1 HDCP input to HDCP 2.2 SUPPORT

Input channel automatic switching

@GUU/@SUU		Automatic switching
Getting	Command	@GUU,device,ch,port<CR><LF>
	Response	@GUU,device,ch,port,autosw<CR><LF>
Setting	Command	@SUU,device,ch,port,autosw<CR><LF>
device: 1 = NJR-L21UC-T 2 = NJR-L31UC-R		
ch: Channel 1 (Fixed)		
port: 1 (Fixed)		
autosw: Automatic switching 0 = Stop 1 = Start		
Getting example		
@GUU,1,1,1<CR><LF>		Getting automatic switching
@GUU,1,1,1,0<CR><LF>		Stop
Setting example		
@SUU,1,1,1,1<CR><LF>		Starting automatic switching

@GAU/@SAU		Signal ON priority
Getting	Command	@GAU,device,ch,port<CR><LF>
	Response	@GAU,device,ch,port,priority_in1,priority_in2,priority_in3<CR><LF>
Setting	Command	@SAU,device,ch,port, priority_in1,priority_in2,priority_in3<CR><LF>
device: 1 = NJR-L21UC-T 2 = NJR-L31UC-R		
ch: Channel 1 (Fixed)		
port: 1 (Fixed)		
priority_in1-3: Signal ON priority (IN1 to IN3) 0 = OFF 1 to 3 = Priority (Highest to Lowest)		
Getting example		
@GAU,1,1,1<CR><LF> @GAU,1,1,1,1,2,3<CR><LF>		Getting the signal ON priority • IN1: 1 • IN2: 2 • IN3: 3
Setting example		
@SAU,1,1,1,3,2,1<CR><LF>		Setting the signal ON priority as follows: • IN1: 3 • IN2: 2 • IN3: 1

@GOF/@SOF		Signal OFF priority
Getting	Command	@GOF,device,ch,port<CR><LF>
	Response	@GOF,device,ch,port,priority_in1,priority_in2,priority_in3,priority_inoff<CR><LF>
Setting	Command	@SOF,device,ch,port,priority_in1,priority_in2,priority_in3,priority_inoff<CR><LF>
device: 1 = NJR-L21UC-T 2 = NJR-L31UC-R		
ch: Channel 1 (Fixed)		
port: 1 (Fixed)		
priority_in1-off: Signal OFF priority IN1 to IN3, INOFF 0 = OFF 1 to 4 = Priority (Highest to Lowest)		
Getting example		
@GOF,1,1,1<CR><LF> @GOF,1,1,1,1,2,3,4<CR><LF>		Getting the signal OFF priority <ul style="list-style-type: none"> ▪ IN1 : 1 ▪ IN2 : 2 ▪ IN3 : 3 ▪ INOFF : 4
Setting example		
@SOF,1,1,1,1,4,3,2,1<CR><LF>		Setting the signal OFF priority <ul style="list-style-type: none"> ▪ IN1 :4 ▪ IN2 :3 ▪ IN3 :2 ▪ INOFF :1

Output audio

@GAM/@SAM		Mute
Getting	Command	@GAM,device,ch,port<CR><LF>
	Response	@GAM,device,ch,port,mute<CR><LF>
Setting	Command	@SAM,device,ch,port,mute<CR><LF>
device: 1 = NJR-L21UC-T 2 = NJR-L31UC-R		
ch: Channel 1 (Fixed)		
port: 1 = SDVoE/HDMI OUT 401 = AUDIO OUT		
mute: 0 = OFF 1 = ON		
Getting example		
@GAM,1,1,0<CR><LF>		Getting the audio mute of SDVoE/HDMI OUT
@GAM,1,1,0,1<CR><LF>		ON
Setting example		
@SAM,1,1,0,0<CR><LF>		Setting the audio mute of SDVoE/HDMI OUT to
		OFF

EDID

@GED/@SED		EDID selection
Getting	Command	@GED,device,ch,port<CR><LF>
	Response	@GED,device,ch,port,edid<CR><LF>
Setting	Command	@SED,device,ch,port,edid<CR><LF>
device: 1 = NJR-L21UC-T 2 = NJR-L31UC-R		
ch: Channel 1 (Fixed)		
port: 1 = IN1 2 = IN2 3 = IN3		
edid: EDID 0 = BULIT-IN EDID 1 = EXTERNAL EDID 401 = COPY DATA		
Getting example		
@GED,1,1,1<CR><LF>		Getting the IN1 EDID selection
@GED,1,1,1,1<CR><LF>		BULIT-IN EDID
Setting example		
@SED,1,1,2,401<CR><LF>		Setting the IN2 EDID selection to COPY DATA

@GVF/@SVF		Resolution																																		
Getting	Command	@GVF,device,ch,port<CR><LF>																																		
	Response	@GVF,device,ch,port,resolution<CR><LF>																																		
Setting	Command	@SVF,device,ch,port,resolution<CR><LF>																																		
device: 1 = NJR-L21UC-T 2 = NJR-L31UC-R																																				
ch: Channel 1 (Fixed)																																				
port: 1 = IN1 2 = IN2 3 = IN3																																				
resolution: <table border="0"> <tr> <td>0 = 800x600 (SVGA)</td> <td>1 = 1024x768 (XGA)</td> </tr> <tr> <td>2 = 1280x720 (VESA720)</td> <td>3 = 720p</td> </tr> <tr> <td>4 = 1280x768 (WXGA)</td> <td>5 = 1280x800 (WXGA)</td> </tr> <tr> <td>6 = 1280x960 (QuadVGA)</td> <td>7 = 1280x1024 (SXGA)</td> </tr> <tr> <td>8 = 1360x768 (WXGA)</td> <td>9 = 1366x768 (WXGA)*</td> </tr> <tr> <td>10 = 1400x1050 (SXGA+)</td> <td>11 = 1440x900 (WXGA+)</td> </tr> <tr> <td>12 = 1600x900 (WXGA++)</td> <td>13 = 1600x1200 (UXGA)</td> </tr> <tr> <td>14 = 1680x1050 (WSXGA+)</td> <td>15 = 1080i*</td> </tr> <tr> <td>16 = 1920x1080 (VESA1080)</td> <td>17 = 1080p</td> </tr> <tr> <td>18 = 1920x1200 (WUXGA)</td> <td>19 = 2048x1152 (QWXGA)</td> </tr> <tr> <td>20 = 2560x1440 (WQHD)</td> <td>21 = 2560x1600 (WQXGA)</td> </tr> <tr> <td>40 = 3840x2160 30Hz</td> <td>41 = 3840x2160 60Hz 4:2:0</td> </tr> <tr> <td>42 = 3840x2160 60Hz 4:4:4</td> <td>43 = 4096x2160 30Hz</td> </tr> <tr> <td>44 = 4096x2160 60Hz 4:2:0</td> <td>45 = 4096x2160 60Hz 4:4:4</td> </tr> <tr> <td>60 = 2560x1080 (UWFHD)</td> <td>61 = 3440x1440 (UWQHD)</td> </tr> <tr> <td>62 = 3840x1600 (UWQHD+)</td> <td>63 = 3840x1080 (DFHD)</td> </tr> <tr> <td>64 = 3240x1080</td> <td></td> </tr> </table>			0 = 800x600 (SVGA)	1 = 1024x768 (XGA)	2 = 1280x720 (VESA720)	3 = 720p	4 = 1280x768 (WXGA)	5 = 1280x800 (WXGA)	6 = 1280x960 (QuadVGA)	7 = 1280x1024 (SXGA)	8 = 1360x768 (WXGA)	9 = 1366x768 (WXGA)*	10 = 1400x1050 (SXGA+)	11 = 1440x900 (WXGA+)	12 = 1600x900 (WXGA++)	13 = 1600x1200 (UXGA)	14 = 1680x1050 (WSXGA+)	15 = 1080i*	16 = 1920x1080 (VESA1080)	17 = 1080p	18 = 1920x1200 (WUXGA)	19 = 2048x1152 (QWXGA)	20 = 2560x1440 (WQHD)	21 = 2560x1600 (WQXGA)	40 = 3840x2160 30Hz	41 = 3840x2160 60Hz 4:2:0	42 = 3840x2160 60Hz 4:4:4	43 = 4096x2160 30Hz	44 = 4096x2160 60Hz 4:2:0	45 = 4096x2160 60Hz 4:4:4	60 = 2560x1080 (UWFHD)	61 = 3440x1440 (UWQHD)	62 = 3840x1600 (UWQHD+)	63 = 3840x1080 (DFHD)	64 = 3240x1080	
0 = 800x600 (SVGA)	1 = 1024x768 (XGA)																																			
2 = 1280x720 (VESA720)	3 = 720p																																			
4 = 1280x768 (WXGA)	5 = 1280x800 (WXGA)																																			
6 = 1280x960 (QuadVGA)	7 = 1280x1024 (SXGA)																																			
8 = 1360x768 (WXGA)	9 = 1366x768 (WXGA)*																																			
10 = 1400x1050 (SXGA+)	11 = 1440x900 (WXGA+)																																			
12 = 1600x900 (WXGA++)	13 = 1600x1200 (UXGA)																																			
14 = 1680x1050 (WSXGA+)	15 = 1080i*																																			
16 = 1920x1080 (VESA1080)	17 = 1080p																																			
18 = 1920x1200 (WUXGA)	19 = 2048x1152 (QWXGA)																																			
20 = 2560x1440 (WQHD)	21 = 2560x1600 (WQXGA)																																			
40 = 3840x2160 30Hz	41 = 3840x2160 60Hz 4:2:0																																			
42 = 3840x2160 60Hz 4:4:4	43 = 4096x2160 30Hz																																			
44 = 4096x2160 60Hz 4:2:0	45 = 4096x2160 60Hz 4:4:4																																			
60 = 2560x1080 (UWFHD)	61 = 3440x1440 (UWQHD)																																			
62 = 3840x1600 (UWQHD+)	63 = 3840x1080 (DFHD)																																			
64 = 3240x1080																																				
*Not for USB-C input connector																																				
Getting example																																				
@GVF,1,1,1<CR><LF>		Getting the IN1 resolution																																		
@GVF,1,1,1,7<CR><LF>		1280x1024																																		
Setting example																																				
@SVF,1,1,1,12<CR><LF>		Setting the IN1 resolution to 1600x900																																		

RS-232C setting

@GCT/@SCT		Command setting
Getting	Command	@GCT,device,ch,port<CR><LF>
	Response	@GCT,device,ch,port,baudrate,databit,stopbit,parity<CR><LF>
Setting	Command	@SCT,device,ch,port,baudrate,databit,stopbit,parity <CR><LF>
device: 1 = NJR-L21UC-T 2 = NJR-L31UC-R		
ch: Channel 1 (Fixed)		
port: 1 = RS-232C* 2 = IN1 (USB-C) *Communication setting for when DIP switch No.1 (“ RS-232C transmission mode (P.6) ”) is set to [ON] (the NJR-L is controlled by a remote device).		
baudrate: Baud rate 0 = 4800 bps 1 = 9600 bps 2 = 14400 bps 3 = 19200 bps 4 = 38400 bps 5 = 57600 bps 6 = 115200 bps		
databit: Data bit length 7 = 7 bit 8 = 8 bit		
stopbit: Stop bit 1 = 1 bit 2 = 2 bit		
parity: Parity check 0 = None 1 = ODD 2 = EVEN		
Getting example		
@GCT,1,1,1<CR><LF> @GCT,1,1,1,3,8,1,0<CR><LF>		Getting the RS-232C communication settings <ul style="list-style-type: none"> ▪ Baud rate : 19200 bps ▪ Data bit length : 8 bit ▪ Stop bit : 1 bit ▪ Parity check : NONE
Setting example		
@SCT,1,1,1,4,8,1,0<CR><LF>		Setting the RS-232C communication as follows: <ul style="list-style-type: none"> ▪ Baud rate : 38400 bps ▪ Data bit length : 8 bit ▪ Stop bit : 1 bit ▪ Parity check : NONE

@GRP/@SRP		Input channel selection
Getting	Command	@GRP,device,ch,port<CR><LF>
	Response	@GRP,device,ch,port,input<CR><LF>
Setting	Command	@SRP,device,ch,port,input <CR><LF>
device 1 = NJR-L21UC-T 2 = NJR-L31UC-R		
ch: Channel 1 (Fixed)		
port: 1 (Fixed)		
input: Input channel 1 = IN1 (USB-C) 2 = IN2 (USB-B)		
Getting example		
@GRP,1,1,1<CR><LF>		Getting the input channel selection
@GRP,1,1,1,2<CR><LF>		IN2 (USB-B)
Setting example		
@SRP,1,1,1,1<CR><LF>		Setting the input channel to IN1 (USB-C)

LAN

@GIP/@SIP		Network
Getting	Command	@GIP,device,ch,port<CR><LF>
	Response	@GIP,device,ch,port,ip_assignment,ipaddress,mask,gateway<CR><LF>
Setting	Command	@SIP,device,ch,port,ip_assignment(,ipaddress,mask,gateway)<CR><LF>
device: 1 = NJR-L21UC-T 2 = NJR-L31UC-R		
ch: Channel 1 (Fixed)		
port: 1 (Fixed)		
ip_assignment: IP assignment 0 = STATIC 1 = DHCP/AutoIP 2 = AutoIP		
ipaddress: IP address 0 to 255 = 8 bits (in decimal) × 4 combinations 192.168.1.199		
mask: Subnet mask 0 to 255 = 8 bits (in decimal) × 4 combinations 255.255.255.0		
gateway: Default gateway 0 to 255 = 8 bits (in decimal) × 4 combinations 0.0.0.0		
Getting example		
@GIP,1,1,1<CR><LF> @GIP,1,1,1,0,192.168.1.199,255.255.255.0,0.0.0.0<CR><LF>		Getting the network settings • IP assignment :STATIC • IP address :192.168.1.199 • Subnet mask :255.255.255.0 • Default gateway : 0.0.0.0
Setting example		
@SIP,1,1,1,1<CR><LF>		Setting the IP assignment to DHCP/AutoIP
Remarks: After the IP assignment is set to [DHCP/AutoIP] or [AutoIP], parameters will be disabled. If the IP assignment is set to [DHCP/AutoIP] or [AutoIP], values that are gotten with [DHCP/AutoIP] or [AutoIP] are applied to IP address, subnet mask, and default gateway for @GIP.		

@GMC		MAC address
Getting	Command	@GMC,device,ch,port<CR><LF>
	Response	@GMC,device,ch,port,unit_1,unit_2,unit_3,unit_4,unit_5,unit_6<CR><LF>
device: 1 = NJR-L21UC-T 2 = NJR-L31UC-R		
ch: Channel 1 (Fixed)		
port: 1 (Fixed)		
unit_1 to unit_6 = Upper bit of the MAC address to Lower bit of the MAC address 00 to FF (in hex)		
Getting example		
@GMC,1,1,1<CR><LF>		Getting the MAC address
@GMC,1,1,1,00,08,E5,77,00,00<CR><LF>		00:08:E5:77:00:00

@GLD/@SLD		Automatic disconnection time (Timeout)
Getting	Command	@GLD,device,ch,port<CR><LF>
	Response	@GLD,device,ch,port,time<CR><LF>
Setting	Command	@SLD,device,ch,port,time<CR><LF>
device: 1 = NJR-L21UC-T 2 = NJR-L31UC-R		
ch: Channel 1 (Fixed)		
port: 1 (Fixed)		
time: Automatic disconnection time 0 = NOT DISCONNECT 1 to 180 = 1 sec. to 180 sec. 30		
Getting example		
@GLD,1,1,1<CR><LF>		Getting the automatic disconnection time
@GLD,1,1,1,30<CR><LF>		30 sec.
Setting example		
@SLD,1,1,1,0<CR><LF>		Setting the automatic disconnection time to NOT DISCONNECT

@G-T/@S-T		LAN RS-232C conversion
Getting	Command	@G-T,device,ch,port<CR><LF>
	Response	@G-T,device,ch,port,mode<CR><LF>
Setting	Command	@S-T,device,ch,port,mode<CR><LF>
device: 1 = NJR-L21UC-T 2 = NJR-L31UC-R		
ch: Channel 1 (Fixed)		
port: 1 (Fixed)		
mode: LAN RS-232C conversion 0 = RECEIVER 1 = CONVERT		
Getting example		
@G-T,1,1,1<CR><LF>		Getting LAN RS-232C conversion
@G-T,1,1,1,0<CR><LF>		RECEIVER
Setting example		
@S-T,1,1,1,1<CR><LF>		Setting LAN RS-232C conversion to CONVERT
Remarks: Only for LAN communication		

Configuring NJR-L

@GPD/@SPD		USB-C Power delivery
Getting	Command	@GPD,device,ch,port<CR><LF>
	Response	@GPD,device,ch,port,pd<CR><LF>
Setting	Command	@SPD,device,ch,port,pd<CR><LF>
device: 1 = NJR-L21UC-T 2 = NJR-L31UC-R		
ch: Channel 1 (Fixed)		
port: 1 (Fixed)		
pd: Power delivery 0 = OFF 1 = 15W 2 = 60W 3 = 65W 4 = 75W		
Getting example		
@GPD,1,1,1 <CR><LF>		Getting the USB-C power delivery
@GPD,1,1,1,2<CR><LF>		60 W
Setting example		
@SPD,1,1,1,0<CR><LF>		Setting the USB-C power delivery to OFF

@GUF/@SUF		USB-C function
Getting	Command	@GUF,device,ch,port<CR><LF>
	Response	@GUF,device,ch,port,func<CR><LF>
Setting	Command	@SUF,device,ch,port,func<CR><LF>
device: 1 = NJR-L21UC-T 2 = NJR-L31UC-R		
ch: Channel 1 (Fixed)		
port: 1 (Fixed)		
func: USB-C function 0 = FULL 1 = DP ALT 2 = DATA 3 = PD ONLY		
Getting example		
@GUF,1,1,1 <CR><LF>		Getting the USB-C function
@GUF,1,1,1,0<CR><LF>		FULL
Setting example		
@SUF,1,1,1,1<CR><LF>		Setting the USB-C function to DP ALT

@GUL/@SUL		USB host lock
Getting	Command	@GUL,device,ch,port<CR><LF>
	Response	@GUL,device,ch,port,lock<CR><LF>
Setting	Command	@SUL,device,ch,port,lock<CR><LF>
device: 1 = NJR-L21UC-T 2 = NJR-L31UC-R		
ch: Channel 1 (Fixed)		
port: 1 (Fixed)		
lock: USB host lock 0 = UNLOCK 1 = LOCK		
Getting example		
@GUL,1,1,1 <CR><LF>		Getting the USB host lock status
@GUL,1,1,1,0<CR><LF>		UNLOCK
Setting example		
@SUL,1,1,1,1<CR><LF>		Locking the USB host

@RBT		Reboot
Setting	Command	@RBT,device,ch,port<CR><LF>
device: 1 = NJR-L21UC-T 2 = NJR-L31UC-R		
ch: Channel 1 (Fixed)		
port: 1 (Fixed)		
Setting example		
@RBT,1,1,1<CR><LF>		Rebooting the NJR-L

@CLR		Initialization
Setting	Command	@CLR,device,ch,port,mode<CR><LF>
device: 1 = NJR-L21UC-T 2 = NJR-L31UC-R		
ch: Channel 1 (Fixed)		
port: 1 (Fixed)		
mode: 0 = ALL INITIALIZE (All settings) 1 = NORMAL INITIALIZE (Setting other than communication settings)		
Setting example		
@CLR,1,1,1,0<CR><LF>		Initializing all settings
Remarks: The NJR-L reboots after initialization.		

Status

@GSS		Input signal/Output signal status										
Getting	Command	@GSS,device,ch,port ,mode<CR><LF>										
	Response	@GSS,device,ch,port,mode,status_1(,status_2,status_3···)<CR><LF>										
device: 1 = NJR-L21UC-T 2 = NJR-L31UC-R												
ch: Channel 1 (Fixed)												
port: 1 = Selected video input channel 101 = OUT												
mode: Target status port = 1 (Selected video input channel) 0 = All of 1 to 4 1 = Input format*1 2 = Input video resolution*2 3 = Input audio format*3 4 = Presence of HDCP input*4 port = 101 (Output connector) 0 = All of 1 to 3 1 = HDCP output*5 2 = Output signal type*6 3 = Error code*7												
status_1-4: I/O signal status												
*1 Input signal type												
<table border="1"> <tr> <td>Hxx</td> <td>HDMI signal is input. Xx stands for color depth (24, 30, or 36).</td> </tr> <tr> <td>D</td> <td>DVI signal is input.</td> </tr> <tr> <td>N</td> <td>No signal is input.</td> </tr> </table>			Hxx	HDMI signal is input. Xx stands for color depth (24, 30, or 36).	D	DVI signal is input.	N	No signal is input.				
Hxx	HDMI signal is input. Xx stands for color depth (24, 30, or 36).											
D	DVI signal is input.											
N	No signal is input.											
*2 Input video resolution												
<table border="1"> <tr> <td>1920x1080p 60.00Hz</td> <td>Signal is input, and Horizontal resolution x Vertical resolution are returned.</td> </tr> <tr> <td>NO SIGNAL</td> <td>No video signal is input.</td> </tr> </table>			1920x1080p 60.00Hz	Signal is input, and Horizontal resolution x Vertical resolution are returned.	NO SIGNAL	No video signal is input.						
1920x1080p 60.00Hz	Signal is input, and Horizontal resolution x Vertical resolution are returned.											
NO SIGNAL	No video signal is input.											
*3 Input audio format												
<table border="1"> <tr> <td>LINEAR PCM 48kHz</td> <td>LPCM signal is input, which returns the sampling frequency.</td> </tr> <tr> <td>LINEAR PCM 48kHz (MULTI CHANNEL)</td> <td>Multi-channel LPCM signal is input, which returns the sampling frequency.</td> </tr> <tr> <td>COMPRESSED AUDIO</td> <td>Bitstream audio (such as Dolby Digital and DTS) is input.</td> </tr> <tr> <td>NO SIGNAL</td> <td>NO audio signal is input.</td> </tr> </table>			LINEAR PCM 48kHz	LPCM signal is input, which returns the sampling frequency.	LINEAR PCM 48kHz (MULTI CHANNEL)	Multi-channel LPCM signal is input, which returns the sampling frequency.	COMPRESSED AUDIO	Bitstream audio (such as Dolby Digital and DTS) is input.	NO SIGNAL	NO audio signal is input.		
LINEAR PCM 48kHz	LPCM signal is input, which returns the sampling frequency.											
LINEAR PCM 48kHz (MULTI CHANNEL)	Multi-channel LPCM signal is input, which returns the sampling frequency.											
COMPRESSED AUDIO	Bitstream audio (such as Dolby Digital and DTS) is input.											
NO SIGNAL	NO audio signal is input.											
*4 HDCP input												
<table border="1"> <tr> <td>HDCP1.4</td> <td>HDCP 1.4 input</td> </tr> <tr> <td>HDCP2.2 Type0</td> <td>HDCP 2.2 Type 0 input</td> </tr> <tr> <td>HDCP2.2 Type1</td> <td>HDCP 2.2 Type 1 input</td> </tr> <tr> <td>HDCP NOT ENCRYPTED</td> <td>No HDCP is input.</td> </tr> <tr> <td>NO SIGNAL</td> <td>No video signal is input.</td> </tr> </table>			HDCP1.4	HDCP 1.4 input	HDCP2.2 Type0	HDCP 2.2 Type 0 input	HDCP2.2 Type1	HDCP 2.2 Type 1 input	HDCP NOT ENCRYPTED	No HDCP is input.	NO SIGNAL	No video signal is input.
HDCP1.4	HDCP 1.4 input											
HDCP2.2 Type0	HDCP 2.2 Type 0 input											
HDCP2.2 Type1	HDCP 2.2 Type 1 input											
HDCP NOT ENCRYPTED	No HDCP is input.											
NO SIGNAL	No video signal is input.											

@GSS	Input signal/Output signal status (Cont'd)	
*5 HDCP output type		
HDCP1.4	HDCP 1.4 output	
HDCP2.2	HDCP 2.2 output	
HDCP2.2 Type0	HDCP 2.2 Type 0 output	
HDCP2.2 Type1	HDCP 2.2 Type 1 output	
HDCP NOT ENCRYPTED	No HDCP is output.	
HDCP ERROR	HDCP authentication failed.	
DURING AUTHENTICATION	HDCP is being encrypted.	
SIGNAL STOPPED	Video synchronous signal stops.	
UNCONNECTED	No sink device is connected.	
*6 Output signal type		
Hxx	HDMI signal is output. Xx stands for color depth (24, 30, or 36).	
D	DVI signal is output.	
C	HDCP is being encrypted and no video is output.	
X	Video synchronous signal stops.	
N	No sink device is connected.	

@GSS		Input signal/Output signal status (Cont'd)	
*7 An error code of the video output is returned first, and then an error code of the digital audio output is returned.			
Error code	Video output status	Audio output status	
0	No error		
1	"@GDB/@SDB Video mute (P.13)" is set to [1] (ON).	"@GAM/@SAM Mute (P.18)" is set to [1] (ON).	
2	Source device is not connected. (No DDC 5 V signal is input.)		
3	No video signal is input.	No audio signal is input.*8	
4	Video or audio output of the source device is muted.		
5	Signal with HDCP is input but sink device is HDCP incompliant. (This error code may also be returned during HDCP authentication.)	—	
6	Source device does not output the returned information (packets) for output of video or audio.		
7	Signal that is not supported by NJR-L (Dot clock is out of range) is input.	Since bitstream audio (such as Dolby Digital and DTS) is input, audio cannot be output (Bitstream audio can be output only to sink devices supporting these audio).	
8	—		
9	—		
A	Input channel selection is set to OFF.		
*8 Since input status of analog input audio cannot be detected, audio may not be output even if [0] is returned.			
Getting example1			
<pre>@GSS,1,1,1,0<CR><LF> @GSS,1,1,1,0,H30,1920x1080p 60Hz, LINEAR PCM 48kHz,HDCP1.4<CR><LF></pre>		Getting all IN statuses <ul style="list-style-type: none"> ▪ Input signal type : 30-BIT COLOR HDMI signal ▪ Video input signal : 1920x1080p 60 Hz ▪ Audio input signal : LINEAR PCM 48k Hz ▪ HDCP : HDCP 1.4 	
Getting example2			
<pre>@GSS,1,1,101,0<CR><LF> @GSS,1,1,101,0,HDCP2.2,H24,00<CR><LF></pre>		Getting OUT1 all statuses <ul style="list-style-type: none"> ▪ HDCP : HDCP 2.2 ▪ Output signal type : 24-BIT COLOR HDMI signal ▪ Error code : Output correctly 	

@GES		Viewing sink device EDID
Getting	Command	@GES,device,ch,port,mode<CR><LF>
	Response	@GES,device,ch,port,mode,status_1(,status_2,status_3,status_4)<CR><LF>
device: 1 = NJR-L21UC-T 2 = NJR-L31UC-R		
ch: Channel 1 (Fixed)		
port: 1 = OUT		
mode: Target status 0 = All of 1 to 4 1 = Sink device name 2 = Recommended resolution and dot clock 3 = HDMI, video signal format, and color depth support status ^{*1} 4 = Audio sampling frequency, bit length, the number of channels, and support status of audio signal format ^{*2}		
status_1-4: EDID status SIGNAL STOPPED : Video output stops. UNCONNECTED : Sink device is not connected. EDID READ ERROR : Reading EDID fails.		
^{*1} For sink device that does not support HDMI : [DVI] is returned. For sink device that supports HDMI : [HDMI] is returned, and then supported video signal format (RGB, YCbCr 4:2:2, YCbCr 4:4:4, and YCbCr 4:2:0 separated with /) and supported color depths (24, 30, and 36, separated with /) are returned in that order.		
^{*2} For sink device that does not support audio : [AUDIO NOT SUPPORT] is returned. For sink device that supports audio : [LINEAR PCM] is returned, and then supported sampling frequencies (32, 44.1, 48, 88.2, 96, 176.4, and 192, separated with /), bit length (16, 20, and 24, separated with /), the number of channels (One of 1 to 8), and [COMPRESSED AUDIO SUPPORT] (If bitstream audio is supported) are returned in that order.		
Getting example		
@GES,1,1,1,0<CR><LF> @GES,1,1,1,0,NJR-L31UC-R,1920x1080 148.50MHz,DVI,AUDIO NOT SUPPORT<CR><LF>		Getting the EDID of the sink device connected to OUT <ul style="list-style-type: none"> • Sink device name : NJR-L31UC-R • Recommended resolution : 1920x1080 • Dot clock : 148.50 MHz • HDMI : Not supported • Audio : Not supported

@GHC		System check
Getting	Command	@GHC,device,ch,port<CR><LF>
	Response	@GHC,device,ch,port,voltage,temp<CR><LF>
device: 1 = NJR-L21UC-T 2 = NJR-L31UC-R		
ch: Channel 1 (Fixed)		
port: 1 (Fixed)		
voltage: Internal voltage status 0 = Normal 1 = Abnormal		
temp: Internal temperature status 0 = Normal 1 = Abnormal		
Getting example		
@GHC<CR><LF>		Getting the system check result <ul style="list-style-type: none"> ▪ Internal voltage status : Abnormal ▪ Internal temperature status : Normal
@GHC,1,0<CR><LF>		

@GIV		Device information
Getting	Command	@GIV,device,ch,port<CR><LF>
	Response	@GIV,device,ch,port,id,ver<CR><LF>
device: 1 = NJR-L21UC-T 2 = NJR-L31UC-R		
ch: Channel 1 (Fixed)		
port: 1 (Fixed)		
id: Model number		
ver: Firmware version		
Getting example		
@GIV,1,1,1<CR><LF>		Getting the product information <ul style="list-style-type: none"> ▪ Model number : NJR-L21UC-T ▪ Firmware version : 01.00.00
@GIV,1,1,1,NJR-L21UC-T,01.00.00<CR><LF>		

Unsolicited status notification

Changes in I/O and internal statuses are notified to external devices over LAN communication (UDP).

To enable the unsolicited notification, set the notification interval (“@SPH Notification interval (P.34)”) to a value other than [0] (OFF).

If no change is detected during the interval, status is sent immediately after detecting a change.

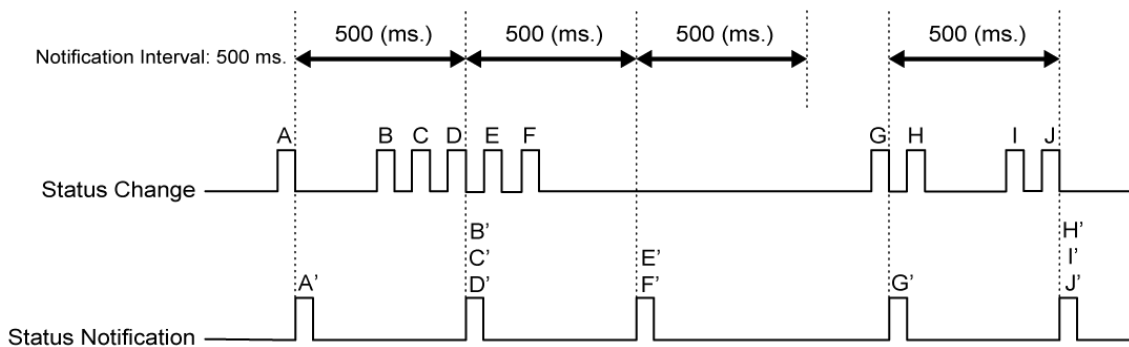

■ Example

1. Set the destination using “@GDA/@SDA IP address/UDP port number of destination (P.33)”.
2. Set the notification interval using “@SPH Notification interval (P.34)”.
3. If any status changes, “@PSHUnsolicited status notification (P.35)” is sent to the set the IP address destination over UDP protocol.
4. Get the changes in input signal, output signal, and alarm status using “@AIN Input signal status (For each connector) (P.36)”, “@AOT Output signal status (For each channel) (P.38)”, and “@GAA Alarm status (P.40)”.

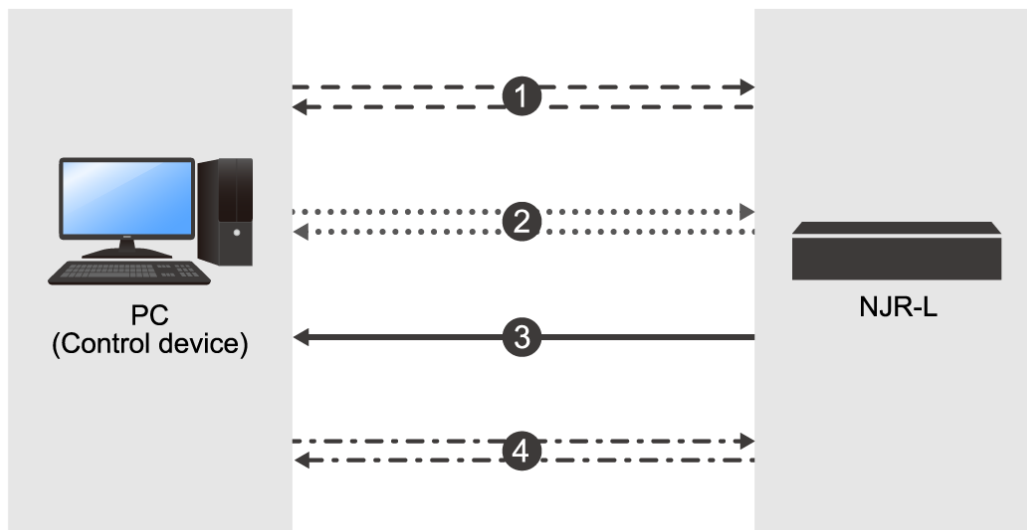

@GDA/@SDA		IP address/UDP port number of destination
Getting	Command	@GDA,device,ch,port,reserve<CR><LF>
	Response	@GDA,device,ch,port,reserve,unit_1,unit_2,unit_3,unit_4,port<CR><LF>
Setting	Command	@SDA,device,ch,port,reserve,unit_1,unit_2,unit_3,unit_4,port<CR><LF>
device: 1 = NJR-L21UC-T 2 = NJR-L31UC-R		
ch: Channel 1 (Fixed)		
port: 1 (Fixed)		
reserve: 1 (Fixed)		
unit_1 to unit_4 = Upper bit of the IP address to Lower bit of the IP address 0 to 255 192.168.1.200		
port: UDP port number 1 to 65535 1147		
Getting example		
@GDA,1,1,1,1<CR><LF> @GDA,1,1,1,1,192,168,1,200,1147<CR><LF>		Getting the IP address/UDP port number of destination <ul style="list-style-type: none"> ▪ IP address : 192.168.1.200 ▪ UDP port number: 1147
Setting example		
@SDA,1,1,1,1,192,168,1,201,1148<CR><LF>		Setting the IP address/UDP port number of destination to 192.168.1.201 and 1148, respectively.
Remarks: If status notification function is enabled (“@GPH/@SPH Notification interval (P.34)” is set to a value other than [0] (OFF)), this command cannot be set.		

@GPH/@SPH		Notification interval																																																																																				
Getting	Command	@GPH,device,ch,port<CR><LF>																																																																																				
	Response	@GPH,device,ch,port,time,save<CR><LF>																																																																																				
Setting	Command	@SPH,device,ch,port,time(,save)<CR><LF>																																																																																				
device: 1 = NJR-L21UC-T 2 = NJR-L31UC-R																																																																																						
ch: Channel 1 (Fixed)																																																																																						
port: 1 (Fixed)																																																																																						
time: Notification time 0 = OFF 1 to 50 = 100 ms to 5000 ms																																																																																						
<table border="1"> <thead> <tr> <th>time</th> <th>ON/OFF</th> <th>Time</th> <th></th> <th>time</th> <th>ON/OFF</th> <th>Time</th> </tr> </thead> <tbody> <tr> <td>0</td> <td>OFF</td> <td>—</td> <td></td> <td>40</td> <td>ON</td> <td>4000 ms</td> </tr> <tr> <td>1</td> <td>ON</td> <td>100 ms</td> <td></td> <td>41</td> <td>ON</td> <td>4100 ms</td> </tr> <tr> <td>2</td> <td>ON</td> <td>200 ms</td> <td></td> <td>42</td> <td>ON</td> <td>4200 ms</td> </tr> <tr> <td>3</td> <td>ON</td> <td>300 ms</td> <td></td> <td>43</td> <td>ON</td> <td>4300 ms</td> </tr> <tr> <td>4</td> <td>ON</td> <td>400 ms</td> <td></td> <td>44</td> <td>ON</td> <td>4400 ms</td> </tr> <tr> <td>5</td> <td>ON</td> <td>500 ms</td> <td>to</td> <td>45</td> <td>ON</td> <td>4500 ms</td> </tr> <tr> <td>6</td> <td>ON</td> <td>600 ms</td> <td></td> <td>46</td> <td>ON</td> <td>4600 ms</td> </tr> <tr> <td>7</td> <td>ON</td> <td>700 ms</td> <td></td> <td>47</td> <td>ON</td> <td>4700 ms</td> </tr> <tr> <td>8</td> <td>ON</td> <td>800 ms</td> <td></td> <td>48</td> <td>ON</td> <td>4800 ms</td> </tr> <tr> <td>9</td> <td>ON</td> <td>900 ms</td> <td></td> <td>49</td> <td>ON</td> <td>4900 ms</td> </tr> <tr> <td>10</td> <td>ON</td> <td>1000 ms</td> <td></td> <td>50</td> <td>ON</td> <td>5000 ms</td> </tr> </tbody> </table>			time	ON/OFF	Time		time	ON/OFF	Time	0	OFF	—		40	ON	4000 ms	1	ON	100 ms		41	ON	4100 ms	2	ON	200 ms		42	ON	4200 ms	3	ON	300 ms		43	ON	4300 ms	4	ON	400 ms		44	ON	4400 ms	5	ON	500 ms	to	45	ON	4500 ms	6	ON	600 ms		46	ON	4600 ms	7	ON	700 ms		47	ON	4700 ms	8	ON	800 ms		48	ON	4800 ms	9	ON	900 ms		49	ON	4900 ms	10	ON	1000 ms		50	ON	5000 ms
time	ON/OFF	Time		time	ON/OFF	Time																																																																																
0	OFF	—		40	ON	4000 ms																																																																																
1	ON	100 ms		41	ON	4100 ms																																																																																
2	ON	200 ms		42	ON	4200 ms																																																																																
3	ON	300 ms		43	ON	4300 ms																																																																																
4	ON	400 ms		44	ON	4400 ms																																																																																
5	ON	500 ms	to	45	ON	4500 ms																																																																																
6	ON	600 ms		46	ON	4600 ms																																																																																
7	ON	700 ms		47	ON	4700 ms																																																																																
8	ON	800 ms		48	ON	4800 ms																																																																																
9	ON	900 ms		49	ON	4900 ms																																																																																
10	ON	1000 ms		50	ON	5000 ms																																																																																
save: Saving setting 0 = Not saving (The notification time will be set to [0] automatically at the next start-up.) 1 = Saving the setting If this parameter is not specified, the setting is not saved.																																																																																						
Getting example																																																																																						
@GPH,1,1,1<CR><LF>		Getting notification time																																																																																				
@GPH,1,1,1,5,1<CR><LF>		<ul style="list-style-type: none"> • Notification time : 500 ms • Saving the setting : Saving the interval setting 																																																																																				
Setting example																																																																																						
@SPH,1,1,1,50,1<CR><LF>		Setting the interval to 5000 ms. and saving the setting																																																																																				

@PSH		Unsolicited status notification						
Getting	Notify	@PSH,in,out,alarm<CR><LF>						
in: Input status 0 = Not changed 1 to FF= Changed								
bit	7	6	5	4	3	2	1	0
in						IN3	IN2	IN1
[1] appears for detected channel, the value is displayed in hex. 1 : Changes in IN 3 : Changes in IN1 and IN2								
out: Output status 0 = Not changed 1 to FF = Changed								
bit	7	6	5	4	3	2	1	0
out								OUT
[1] appears for detected channel, the value is displayed in hex. 1 : Changes in OUT								
alarm: Alarm status 0 = Not changed 1 = Changed								
Getting example								
@PSH,1,0,0<CR><LF>					Getting the status change <ul style="list-style-type: none"> • Input status : IN1 • Output status : Not changed • Alarm status : Not changed 			
Remarks: Only if status notification function is enabled ("@GPH/@SPH Notification interval (P.34)" is set to a value other than [0] (OFF)), the command can be sent.								

@AIN		Input signal status (For each connector)
Getting	Command	@AIN,in<CR><LF>
	Response	@AIN,status_1,status_2,status_3,status_4,status_5,status_6,status_7,status_8, status_9,status_10,status_11,status_12,status_13,status_14,status_15,status_16, status_17,status_18,status_19<CR><LF>
in: Target connector 1 to 3 = IN1 to IN3		
status_1: Input connector 1 to 3 = IN1 to IN3		
status_2: Model number		
status_3: Firmware version		
status_4: The number of valid data = 15 (Fixed)		
status_5: 1 (Fixed)		
status_6: Horizontal resolution of input video 0 = No signal is input 1920 = 1920 pixels		
status_7: Vertical resolution of input video 0 = No signal is input 1080 = 1080 lines		
status_8: Vertical sync frequency of input video 0 = No signal is input 59.94 = 59.94 Hz		
status_9: Progressive or interlace scan 0 = No signal is input 1 = Progressive 2 = Interlace		
status_10: HDMI/DVI mode of input video 0 = No signal is input 1 = DVI 2 = HDMI		
status_11: Video signal format of input video 0 = No signal is input 1 = RGB 2 = YCbCr 4:2:2 3 = YCbCr 4:4:4 4 = YCbCr 4:2:0 255 = Unknown		
status_12: Color range of input video 0 = No signal is input. 1 = Limited range 2 = Full range		
status_13: Color depth of input video 0 = No signal is input 1 = 24bit/pixel (8bit/component) 2 = 30bit/pixel (10bit/component) 3 = 36bit/pixel (12bit/component)		
status_14: DDC 5 V input status 0 = No signal is input. 1 = Signal is input		
status_15: Presence of HDCP 0 = No signal is input 1 = Without HDCP 2 = HDCP 1.4 3 = HDCP 2.2 Type 0 4 = HDCP 2.2 Type 1		
status_16: Format of input audio 0 = No signal is input. 1 = LPCM 2 = Bitstream audio		
status_17: Sampling frequency of input audio 0 = No signal is input 1 = 22.05 kHz 2 = 24 kHz 3 = 32 kHz 4 = 44.1 kHz 5 = 48 kHz 6 = 88.2 kHz 7 = 96 kHz 8 = 176.4 kHz 9 = 192 kHz 10 = 768 kHz 11 = 64 kHz 12 = 128 kHz 255 = Unknown		
status_18: Bit length of input audio 0 = No signal is input 1 = 16 bit 2 = 17 bit 3 = 18 bit 4 = 19 bit 5 = 20 bit 6 = 21 bit 7 = 22 bit 8 = 23 bit 9 = 24 bit 255 = Unknown		
status_19: HBR mode of input audio 0 = No signal is input. More other than HBR (LPCM, other Bitstream audio) 2 = HBR mode		

@AIN	Input signal status (For each channel) (Cont'd)
Getting example	
<pre>@AIN,1<CR><LF> @AIN,1,NJR-L21UC-T,01.00.00, 15,1,1920,1080,59.94,1,2,1,2,1,1,2, 1,5,9,1<CR><LF></pre>	<pre>Getting IN1 input signal status • Input connector : IN1 • Model number : NJR-L21UC-T • Firmware version : 01.00.00 • The number of valid data : 15 • Reserve : 1 (Fixed) • Horizontal resolution of input video : 1920 pixels • Vertical resolution of input video : 1080 lines • Vertical sync frequency of input video : 59.94 Hz • Progressive or interlace scan : Progressive • HDMI/DVI mode of input video : HDMI • Video signal format of input video : RGB • Color range of input video : Full range • Color depth of input video : 24 bit/pixel (8 bit/component) • DDC 5 V input status : Signal is input • Presence of HDCP : HDCP 1.4 • Format of input audio : LPCM • Sampling frequency of input audio : 48 kHz • Bit length of input audio : 24 bit • HBR mode of input audio : Mode other than HBR</pre>

@AOT		Output signal status (For each channel)
Getting	Command	@AOT,out<CR><LF>
	Response	@AOT,status_1,status_2,status_3,status_4,status_5,status_6,status_7,status_8, status_9,status_10,status_11,status_12,status_13,status_14,status_15,status_16, status_17,status_18,status_19,status_20,status_21,status_22,status_23,status_24, status_25<CR><LF>
out: Target connector 1 = OUT		
status_1: Output connector 1 = OUT		
status_2: Model number		
status_3: Firmware version		
status_4: The number of valid data = 21 (Fixed)		
status_5: 1 (Fixed)		
status_6: Selected input channel 0 = OFF 1 to 3 = IN1 to IN3		
status_7: Horizontal resolution of output video 0 = No signal is output 1920 = 1920 pixels		
status_8: Vertical resolution of output video 0 = No signal is output 1080 = 1080 lines		
status_9: Vertical sync frequency of output video 0 = No signal is output 59.94 = 59.94 Hz		
status_10: Progressive or interlace scan 0 = No signal is output 1 = Progressive 2 = Interlace		
status_11: HDMI/DVI mode of output video 0 = No signal is output 1 = DVI 2 = HDMI		
status_12: Video signal format of output video 0 = No signal is output 1 = RGB 2 = YCbCr 4:2:2 3 = YCbCr 4:4:4 4 = YCbCr 4:2:0		
status_13: Color range of output video 0 = No signal is output 1 = Limited range 2 = Full range		
status_14: Color depth of output video 0 = No signal is output 1 = 24bit/pixel (8bit/component) 2 = 30bit/pixel (10bit/component) 3 = 36bit/pixel (12bit/component)		
status_15: Hot plug detection 0 = No hot plug is detected. 1 = Hot plug is detected.		
status_16: HDCP encryption 0 = No HDCP encryption 1 = HDCP is being encrypted. 2 = HDCP is being encrypted. 3 = HDCP is being encrypted. 4 = HDCP encryption ends normally. 5 = HDCP encryption ends abnormally.		
status_17: HDCP output 0 = No HDCP output 1 = HDCP 1.4 2 = HDCP 2.2 Type 0 3 = HDCP 2.2 Type 1		
status_18: Output audio format 0 = No signal is output 1 = LPCM 2 = Bitstream audio		
status_19: Reading EDID 0 = Sink device is not connected. 1 = Failed 2 = Completed 255 = N/A		
status_20: HDMI/DVI mode (Sink) 0 = Sink device is not connected. 1 = DVI 2 = HDMI (LPCM supported) 3 = HDMI (Bitstream audio supported) 255 = N/A		

@AOT	Output signal status (For each channel) (Cont'd)							
status_21: Video signal format (Sink)								
bit	7	6	5	4	3	2	1	0
Color	N/A	-	-	-	YCbCr 4:2:0	YCbCr 4:4:4	YCbCr 4:2:2	RGB
<ul style="list-style-type: none"> • "1" appears for supported video signal format, the value is displayed in decimal. • [0] : Sink device is not connected. • [128] : N/A 								
status_22: Color depth (Sink)								
0 = Sink device is not connected. 1 = HDCP is not supported. 2 = HDCP 1.4 supported 3 = HDCP 2.2 supported 255 = N/A								
status_23: HDCP (Sink)								
0 = Sink device is not connected. 1 = HDCP is not supported. 2 = HDCP 1.4 supported 3 = HDCP 2.2 supported 255 = N/A								
status_24: SCDC (Sink)								
0 = Sink device is not connected. 1 = SCDC is not supported. 2 = SCDC supported 255 = N/A								
status_25: HDR (Sink)								
0 = Sink device is not connected. 1 = HDR is not supported. 2 = HDR supported 255 = N/A								
Getting example								
<pre>@AOT,1<CR><LF> @AOT,1,NJR-L21UC-T, 01.00.00,21,1,1,1920, 1080,59.94,1,2,1,2,1,1, 4,1,1,2,2,7,1,2,2,2 <CR><LF></pre>	Getting the OUT output signal statuses <ul style="list-style-type: none"> • Output connector : OUT • Model number : NJR-L21UC-T • Firmware version : 01.00.00 • The number of valid data : 21 • Reserve : 1 (FIXED) • Selected input channel : IN1 • Horizontal resolution of output video : 1920 pixels • Vertical resolution of output video : 1080 lines • Vertical sync frequency of output video : 59.94 Hz • Progressive or interlace scan : Progressive • HDMI/DVI mode of output video : HDMI • Video signal format of output video : RGB • Color range of output video : Full range • Color depth of output video : 24 bit/pixel (8 bit/component) • Hot plug detection : Hot plug is detected. • HDCP encryption : HDCP encryptions ends normally. • HDCP output : HDCP 1.4 • Output audio format : LPCM • Reading EDID : Completed • HDMI/DVI mode (Sink) : HDMI (LPCM supported) • Video signal format (Sink) : RGB, YCbCr 4:4:4, and YCbCr 4:2:2 supported • Color depth (Sink) : 24 bit/pixel (8 bit/component) • HDCP (Sink) : HDCP 1.4 supported • SCDC (Sink) : SCDC supported • HDR (Sink) : HDR supported 							

@GAA		Alarm status
Getting	Command	@GAA<CR><LF>
	Response	@GAA,status_1,status_2,status_3,status_4,status_5<CR><LF>
status_1: Model number		
status_2: Firmware version		
status_3: The number of valid data = 2 (Fixed)		
status_4: Power voltage status 0 = Normal 1 = Abnormal		
status_5: Temperature status 0 = Normal 1 = Abnormal		
Getting example		
@GAA<CR><LF> @GAA,NJR-L21UC-T,01.00.00,2,0,0<CR><LF>		Getting alarm status ▪ Model number : NJR-L21UC-T ▪ Firmware version : 01.00.00 ▪ The number of valid data : 2 ▪ Power voltage status : Normal ▪ Temperature status : Abnormal

HDMI/USB-C Encoder/Decoder

NJR-L21UC-T/L31UC-R

Command Guide



www.idkav.com

Headquarters

IDK Corporation
7-9-1 Chuo, Yamato, Kanagawa, 242-0021, JAPAN
TEL: +81-46-200-0764 FAX: +81-46-200-0765
Email: idk_eng@idk.co.jp

USA

IDK America Inc.
72 Grays Bridge Road Suite 1-C, Brookfield,
CT 06804, United States
TEL: +1-203-204-2445
Email: sales@idkav.com

Europe

IDK Europe GmbH
Lise-Meitner-Str. 6, D-40878 Ratingen, Germany
TEL: +49-2102-578-301-0
Email: info@idkav.eu

Vietnam

IDK Corporation Vietnam	IDK Corporation Vietnam
Hanoi Representative Office	Ho Chi Minh Representative Office
TEL: +84-247-108-8866	TEL: +84-28-7108-8954
Email: info_en@idk.co.jp	Email: info_en@idk.co.jp