

Programmable Button Controller

SWC-2000

<User Guide>

Ver.1.8.0

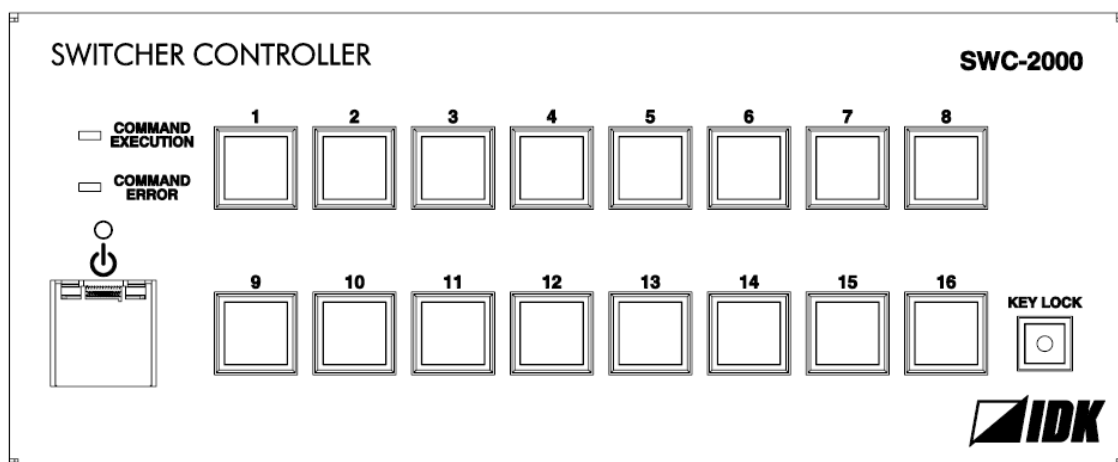

- Thank you for choosing our product.
- To ensure the best performance of this product, please read this user guide fully and carefully before using it and keep this manual together with the product for future reference as needed.

Trademarks

- Microsoft, Windows, Internet Explorer are either registered trademarks or trademarks of the Microsoft Corporation in the United States and other countries.
- PJLink is a trademark in Japan, the United States, and other countries/regions.
- Javascript® is a trademark or registered trademark of Oracle Corporation, its subsidiaries, and affiliated companies in the United States and other countries.
- Oracle and Java are trademarks of Oracle Corporation its subsidiaries, and affiliated companies in the United States and other countries.
- All other company and product names mentioned in this manual are either registered trademarks or trademarks of their respective owners. In this manual, the “®” or “™” marks may not be specified.

Before reading this manual

- All rights reserved.
- Some information contained in this User guide such as exact product appearance, diagrams, menu operations, and so on may differ depending on the product version.
- This User guide is subject to change without notice. You can download the latest version from IDK's website at: www.idkav.com

The reference manual consists of the following two volumes:

- User guide (this document):
Provides explanations and procedures for operations, installation, connections among devices, I/O adjustment and settings.
- Command guide: Please download the command guide from the website above.
Provides explanations and procedures for external control using RS-232C and LAN communications.

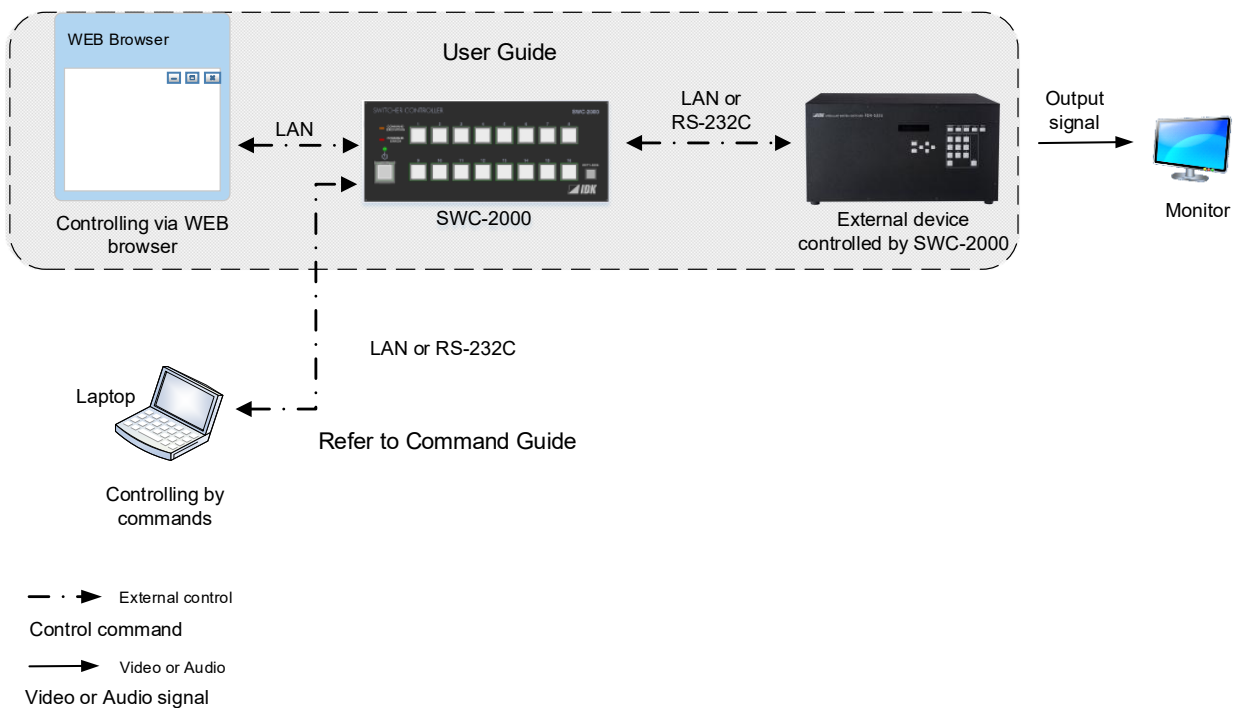

FCC STATEMENT

Note: This equipment has been tested and found to comply with the limits for a Class A digital device, pursuant to part 15 of the FCC Rules. These limits are designed to provide reasonable protection against harmful interference when the equipment is operated in a commercial environment. This equipment generates, uses, and can radiate radio frequency energy and, if not installed and used in accordance with the instruction manual, may cause harmful interference to radio communications. Operation of this equipment in a residential area is likely to cause harmful interference, in which case the user will be required to correct the interference at his own expense.

(Class A)

**Supplier's Declaration of Conformity
47 CFR § 2.1077 Compliance Information**

Unique Identifier

Type of Equipment: SWITCHER CONTROLLER

Model Name: SWC-2000

Responsible Party – U.S. Contact Information

Company Name: IDK America Inc.

Address: 72 Grays Bridge Road Suite 1-C, Brookfield, CT 06804

Telephone number: +1-203-204-2445

URL: www.idkav.com

FCC Compliance Statement

This device complies with Part 15 of the FCC Rules. Operation is subject to the following two conditions: (1) This device may not cause harmful interference, and (2) this device must accept any interference received, including interference that may cause undesired operation.

(FCC SDoC)

CE MARKING

This equipment complies with the essential requirements of the relevant European health, safety and environmental protection legislation.

WEEE MARKING



Waste Electrical and Electronic Equipment (WEEE), Directive 2002/96/EC
(This directive is only valid in the EU.)



This equipment complies with the WEEE Directive (2002/96/EC) marking requirement.







The left marking indicates that you must not discard this electrical/electronic equipment in domestic household waste.

Safety Instructions

Read all safety and operating instructions before using this product. Follow instructions and heed warnings/cautions.

Instructions and warnings/cautions for all products are provided. Some of them may not be applicable to your product.

	<h2>Warning</h2>	Indicates the presence of a hazard that may result in death or serious personal injury if the warning is ignored or the product is handled incorrectly.
	<h2>Caution</h2>	Indicates the presence of a hazard that may cause minor personal injury or property damage if the caution is ignored or the product is handled incorrectly.

Symbol	Description	Example
 Caution	This symbol is intended to alert the user. (Warning and caution)	 Hot surfaces Caution
 Prohibited	This symbol is intended to prohibit the user from specified actions.	 Do not disassemble
 Instruction	This symbol is intended to instruct the user.	 Unplug

Warning

For lifting heavy products:

 Instruction	<ul style="list-style-type: none"> ● Lifting must be done by two or more personnel. <p>To avoid injury: When lifting the product, bend your knees, keep your back straight and get close to it with two or more persons.</p>
--	--





For installing and connecting products:

 Prohibited	<ul style="list-style-type: none"> ● Do not place the product in unstable place. <p>Install the product in a horizontal and stable place, as this may fall or tip over and cause injury.</p> <ul style="list-style-type: none"> ● Secure the product if installing in the locations with vibration. <p>Vibration may move or tip over the product unexpectedly, resulting in injury.</p>
---	--

Warning

 Instruction	<ul style="list-style-type: none"> ● Installation work must be performed by professionals. The product is intended to be installed by skilled technicians. For installation, please contact a system integrator or IDK. Improper installation may lead to the risk of fire, electric shock, injury, or property damage. ● Insert the power plug into an outlet that is unobstructed. Unobstructed access to the plug enables unplugging the product in case of any extraordinary failure, abnormal situation or for easy disconnection during extended periods of non-use. ● Insert the power plug into an appropriate outlet completely. If the plug is partially inserted, arcing may cause the connection to overheat, increasing the risk of electric shock or fire. Do not use a damaged plug or connect to a loose outlet. ● Unplug the product from an AC power source during installation or service. When connecting peripheral devices to this product, unplug all involved devices from outlets. Ground potential differences may cause fire or other difficulties. ● The product must be electrically earthed/grounded. To reduce the risk of electric shock, ensure the product is connected to a mains socket outlet with a protective earthing connection. ● For powering/powered functions, compatible cables must be used. Otherwise, it may cause problems or a fire.
---	---

For operating products:

 Prohibited	<ul style="list-style-type: none"> ● Keep out any foreign objects. To avoid fire or electric shock, do not permit foreign objects, such as metal and paper, to enter the product from vent holes or other apertures. ● For power cables/plugs, AC adapters, and cables for powering/powered functions, <ul style="list-style-type: none"> • Do not scratch, heat, or modify, including splicing or lengthening them. • Do not pull, place heavy objects on them, or pinch them. • Do not bend, twist, tie or clamp them together forcefully. <p>Misuse of the power cable and plug may cause fire or electric shock. If power cables/plugs become damaged, contact your IDK representative.</p>
 Do not disassemble	<ul style="list-style-type: none"> ● Do not repair, modify or disassemble. Since the product includes circuitry that uses potentially lethal, high voltage levels, disassembly by unauthorized personnel may lead to the risk of fire or electric shock. For internal inspection or repair, contact your IDK representative.
 Do not touch	<ul style="list-style-type: none"> ● Do not touch the product and connected cables during electric storms. Contact may cause electric shock.
 Instruction	<ul style="list-style-type: none"> ● Clean the power plug regularly. If the plug is covered in dust, it may increase the risk of fire.



If the following problem occurs:

 Unplug	<ul style="list-style-type: none"> ● Unplug immediately if the product smokes, makes unusual noise, or produces a burning odor. ● Unplug immediately if the product is damaged by falling or having been dropped. ● Unplug immediately if water or other objects are directed inside. <p>If you continue to use the product under these conditions, it may increase the risk of electric shock or fire. For maintenance and repair, contact your IDK representative.</p>
--	--



Caution

For installing and connecting products:

 <p>Prohibited</p>	<ul style="list-style-type: none"> ● Do not place the product in a location where it will be subjected to high temperatures. If the product is subjected to direct sunlight or high temperatures while under operation, it may affect the product's performance and reliability and may increase the risk of fire. ● Do not store or operate the product in dusty, oil smoke filled, or humid place. Placing the product in such environment may increase the risk of fire or electric shock. ● Do not block the vent holes. If ventilation slots are blocked, it may cause the product to overheat, affecting performance and reliability and may increase the risk of fire. ● Do not place or stack heavy items on the product. Failure to observe this precaution may result in damage to the product itself as well as other property and may lead to the risk of personal injury. ● Do not exceed ratings of outlet and wiring devices. Exceeding the rating of an outlet may increase the risk of fire and electric shock.
 <p>No wet hands</p>	<ul style="list-style-type: none"> ● Do not handle power plug with wet hands. Failure to observe this precaution may increase the risk of electric shock.
 <p>Instruction</p>	<ul style="list-style-type: none"> ● Use and store the product within the specified temperature/humidity range. If the product is used outside the specified range of temperature and humidity continuously, it may increase the risk of fire or electric shock. ● Do not place the product at elevations of 1.24 mi. (2,000 m) or higher above sea level. Failure to do so may shorten the life of the internal parts and result in malfunctions. ● When mounting the product into the rack, provide sufficient cooling space. Mount the product in a rack meeting EIA standards, and maintain spaces above and below for air circulation. For your safety as required, attach an L-shaped bracket in addition to the panel mount bracket kit to improve mechanical stability. ● Never insert screws without the rubber feet into the threaded holes on the bottom of the product. Never insert screws alone into the threaded holes on the bottom of the product. Doing so may lead to damage when the screws contact electric circuitry or components inside the product. Reinstall the originally supplied rubber feet using the originally supplied screws only.

For operating products:





 <p>Hot surfaces Caution</p>	<p>For products with the hot surfaces caution label only:</p> <ul style="list-style-type: none"> ● Do not touch the product's hot surface. <p>If the product is installed without enough space, it may cause malfunction of other products. If you touch product's hot surface, it may cause burns.</p>
 <p>Prohibited</p>	<ul style="list-style-type: none"> ● Use only the supplied power cable and AC adapter. ● Do not use the supplied power cable and AC adapter with other products. <p>If non-compliant adapter or power cables are used, it may increase the risk of fire or electric shock.</p>
 <p>Unplug</p>	<ul style="list-style-type: none"> ● If the product won't be used for an extended period of time, unplug it. <p>Failure to observe this precaution may increase the risk of fire.</p> <ul style="list-style-type: none"> ● Unplug the product before cleaning. <p>To prevent electric shock.</p>
 <p>Instruction</p>	<ul style="list-style-type: none"> ● Do not prevent heat release. <p>If cooling fan stops, power off the product and contact IDK. Failure to do so may raise internal temperature and increase the risk of malfunction, fire, or electric shock.</p> <ul style="list-style-type: none"> ● Keep vents clear of dust. <p>If the vent holes near the cooling fan or near the fan are covered with dust, internal temperatures increase and may increase the risk of malfunction. Clean the vent holes and near the fan as needed. If dust accumulates inside of the product, it may increase the risk of fire or electric shock. Periodic internal cleaning, especially before humid rainy season, is recommended. For internal cleaning, contact your IDK representative.</p>

Table of Contents

1	Included Items	12
2	Rack mount kit	13
2.1	Rack mount kit for one SWC-2000	14
2.1.1	Attaching mounting bracket for one SWC-2000.....	15
2.2	Rack mount kit for two SWC-2000s.....	16
2.2.1	Attaching mounting bracket for two SWC-2000s	17
3	About SWC-2000	18
4	Features	19
5	Front and Rear panels	20
6	Connecting to External device	21
6.1	Preparations.....	21
6.2	Precautions	21
6.3	Typical SWC-2000 applications.....	22
7	Basic operations	23
7.1	Starting SWC-2000	23
7.2	Powering ON/OFF	23
7.3	Rebooting.....	23
7.4	Power-on (supplied from AC adapter) status	23
7.5	Initializing	24
7.6	Control status LEDs	24
7.7	Executing control commands.....	25
7.8	Key lock	26
8	How to use SWC-2000	27
8.1	Application example.....	27
8.1.1	Preparation for LAN connection	27
8.1.2	Setting SWC-2000	28
8.2	Controlling external device from SWC-2000.....	34
8.2.1	Control from control command buttons	34
8.2.2	Control from WEB browser	34
9	WEB menu	35
9.1	About WEB menu	35
9.2	MAIN menu	36
9.2.1	Control status boxes	37
9.2.2	Standby button	37
9.2.3	Control command buttons	37
9.2.4	AUTO RELOAD TIMER	38
9.2.5	RELOAD button	38
9.3	NAME EDIT menu	39
9.3.1	WEB menu links	40
9.3.2	BUTTON NAME EDIT	40
9.3.3	RELOAD button	40
9.3.4	SEND button	40
9.4	DATA MONITOR menu	41
9.4.1	WEB menu links	42
9.4.2	DATA MONITOR.....	42
9.4.3	HEX / ASCII button	42
9.4.4	STOP / RUN button.....	42

9.4.5	CLEAR button	42
9.5	COMMAND EDIT menu (Control command list)	43
9.5.1	WEB menu links	44
9.5.2	EXTERNAL CONTROL COMMAND LIST	44
9.5.3	COMMAND COPY / DELETE	44
9.5.4	RELOAD button	44
9.6	COMMAND EDIT menu (Advanced setting of control command)	45
9.6.1	WEB menu links	46
9.6.2	Setting control command	46
9.6.3	LINK button	50
9.6.4	TEMPLATE button	51
9.6.5	RELOAD button	58
9.6.6	BACK button.....	58
9.6.7	SEND button	58
9.7	REPLY COMMAND menu (Reply command list)	59
9.7.1	WEB menu links	60
9.7.2	REPLY COMMAND LIST	60
9.7.3	REPLY COMMAND COPY/DELETE	60
9.7.4	Reload button	60
9.8	REPLY COMMAND menu (Advanced setting of reply command)	61
9.8.1	WEB menu links	62
9.8.2	Setting reply command	62
9.8.3	TEMPLATE button	65
9.8.4	RELOAD button	69
9.8.5	BACK button.....	69
9.8.6	SEND button	69
9.9	COMMAND LINK menu (Selecting button).....	70
9.9.1	WEB menu links	71
9.9.2	STANDBY BUTTON	71
9.9.3	COMAND LINK COPY/DELETE	71
9.9.4	INVALID TIME.....	72
9.9.5	RELOAD button	72
9.10	COMMAND LINK menu	73
9.10.1	WEB menu links	74
9.10.2	TOGGLE and COMMAND (Linking control command).....	74
9.10.3	RELOAD button	75
9.10.4	BACK button.....	75
9.10.5	SEND button	75
9.11	COMMAND EXECUTION menu	76
9.11.1	WEB menu links	77
9.11.2	EXTERNAL CONTROL COMMAND LIST	77
9.11.3	COMMAND EXECUTION/COMMAND ERROR indicator	77
9.12	LED menu	78
9.12.1	WEB menu links	79
9.12.2	Blinking pattern.....	79
9.12.3	Lighting condition	79
9.12.4	RELOAD button	81
9.12.5	SEND button	81
9.12.6	LAST BUTTON MEMORY (Start-up lighting by group)	81
9.13	LAN / COM menu.....	82

9.13.1	WEB menu links	83
9.13.2	LAN SETTING	83
9.13.3	Operation mode of LAN communication	84
9.13.4	COM SETTING	85
9.13.5	RELOAD button	85
9.13.6	SEND button	85
9.14	BACKUP / RESTORE menu.....	86
9.14.1	WEB menu links	87
9.14.2	BACKUP.....	87
9.14.3	RESTORE	87
9.15	OTHERS	88
9.15.1	WEB menu links	89
9.15.2	POWER ON SETTING STANDBY BUTTON.....	89
9.15.3	KEY LOCK BUTTON	89
9.15.4	AUTO LOCK.....	89
9.15.5	BUZZER	89
9.15.6	VERSION	90
9.15.7	RELOAD button	90
9.15.8	SEND button	90
10	Product specification.....	91
11	Troubleshooting	92

1 Included Items

Ensure that all items below are included in the package.

If any items are missing or damaged, please contact IDK.

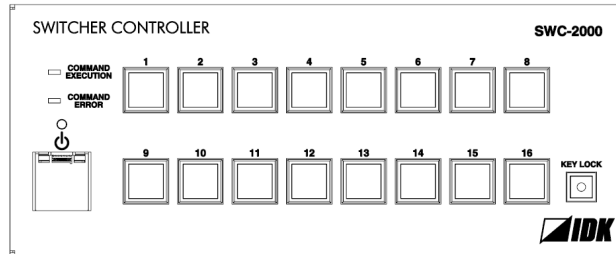

One (1) main unit (SWC-2000)

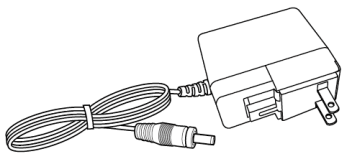

One (1) AC adapter

[Fig. 1.1] Included items

2 Rack mount kit

We offer rack mount kits for SWC-2000 as optional extra. By using this kit, you can mount one or two SWC-2000s to an EIA rack.

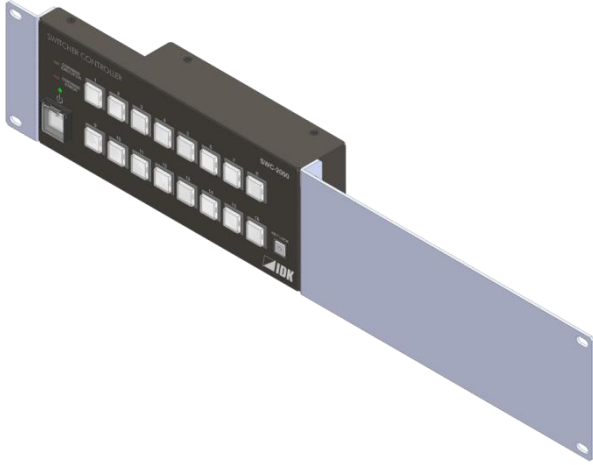

[Fig. 2.1] RM-SWC2001

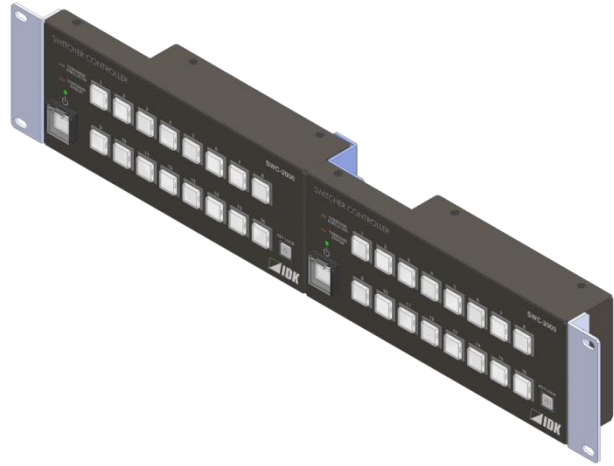

[Fig. 2.2] RM-SWC2002

*The actual color of kits is black.

[Table 2.1] Part number of rack mount kit

RM-SWC2001	For one SWC-2000
RM-SWC2002	For two SWC-2000s

2.1 Rack mount kit for one SWC-2000

Check if all the following items are included.

[Table 2.2] RM-SWC2001

Part number	Included items
RM-SWC2001	<ul style="list-style-type: none"> • 701A05 mounting bracket (1) • 701A06 mounting bracket for one SWC-2000 (1) • Screw: Nickel-plated iron M3x6 screws (4)

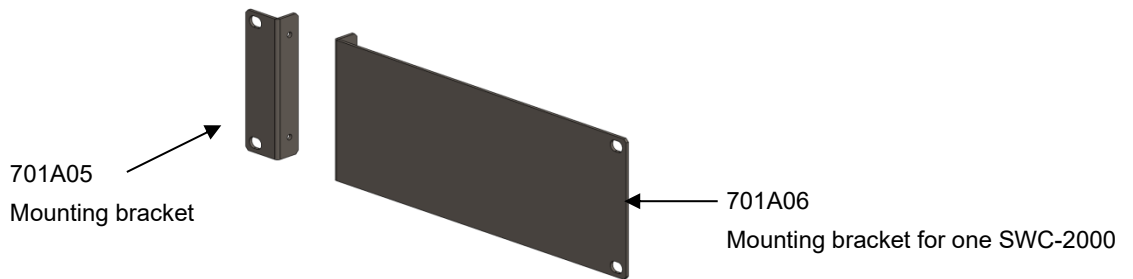

[Fig. 2.3] RM-SWC2001

2.1.1 Attaching mounting bracket for one SWC-2000

1. Remove the bracket below from the SWC-2000's bottom.

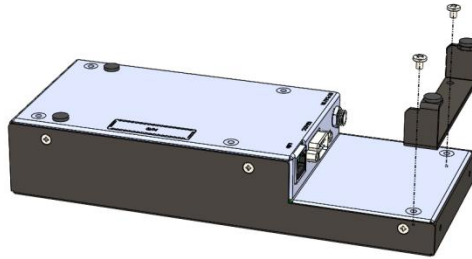

[Fig. 2.4] Removing bracket

2. Attach the mounting brackets (701A05 and 701A06) with screws to the SWC-2000's bottom.
The tightening torque is 0.59 N·m (6.1 kgf·cm approx.).
701A05 and 701A06 can be left-right reverse.

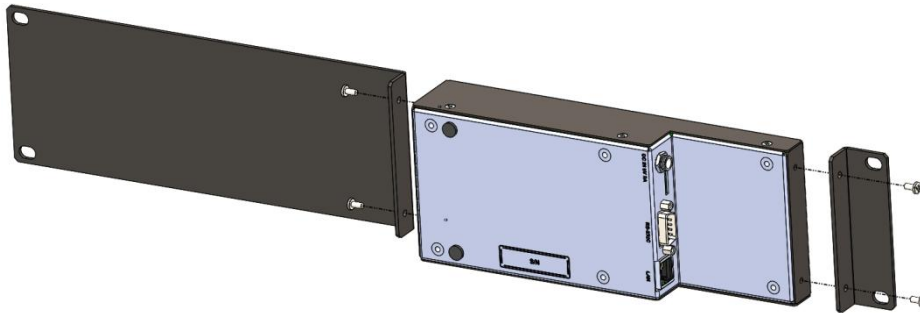

[Fig. 2.5] Attaching brackets

2.2 Rack mount kit for two SWC-2000s

Check if all the following items are included.

[Table 2.3] RM-SWC2002

Part number	Included items
RM-SWC2002	<ul style="list-style-type: none"> • 701A04 rack mounting bracket (1) • 701A05 mounting bracket for double SWC-2000 (2) • Screw: Nickel-plated iron M3x6 screws (8)

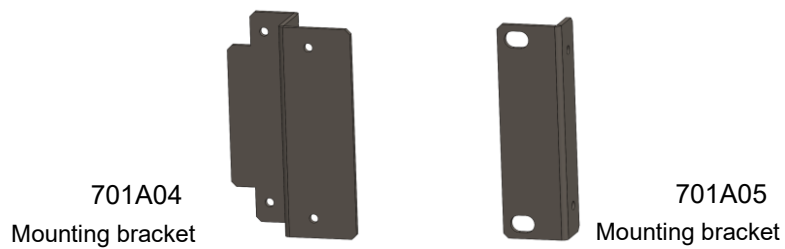

[Fig. 2.6] For RM-SWC2002

2.2.1 Attaching mounting bracket for two SWC-2000s

1. Remove the bracket below from SWC-2000's bottom.

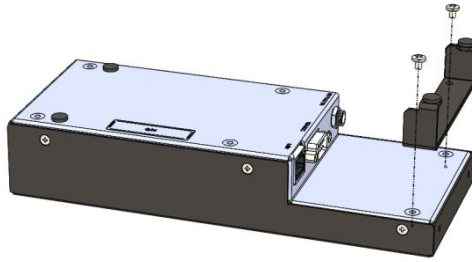

[Fig. 2.7] Removing bracket

2. Attach the mounting bracket (701A04) to the two SWC-2000s' bottoms with screws to connect them. Attach the mounting brackets (701A05) to the two SWC-2000's sides as shown below. The tightening torque is 0.59 N·m (6.1 kgf·cm approx.).

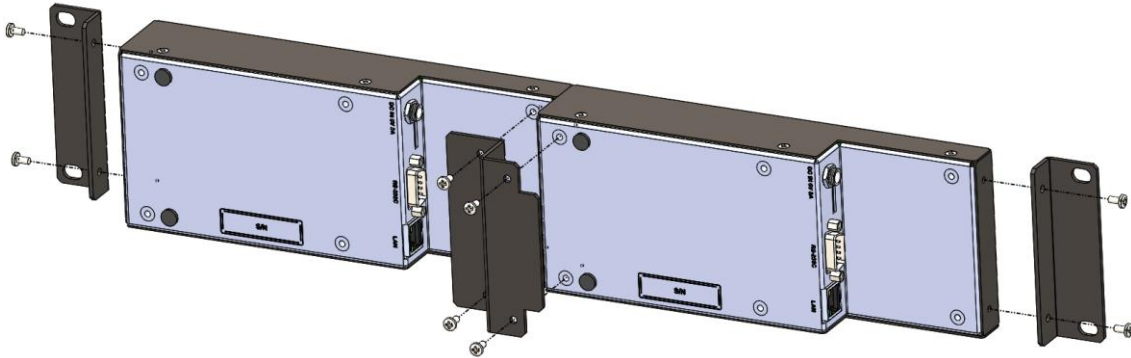

[Fig. 2.8] Attaching brackets

3 About SWC-2000

The SWC-2000 is a remote controller that controls Matrix switchers, multiple switchers, and projectors. The SWC-2000 allows you to power on/off projectors and switch video of matrix switchers remotely. You can set and operate the SWC-2000 remotely over a WEB browser using a PC.

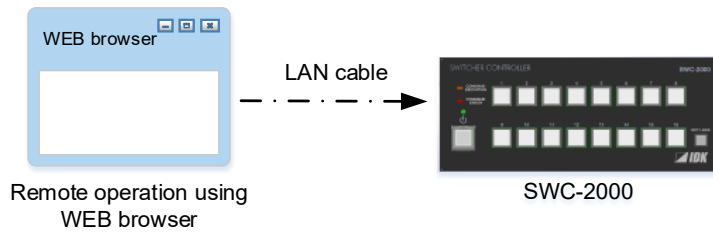

[Fig. 3.1] Remote operation using WEB browser

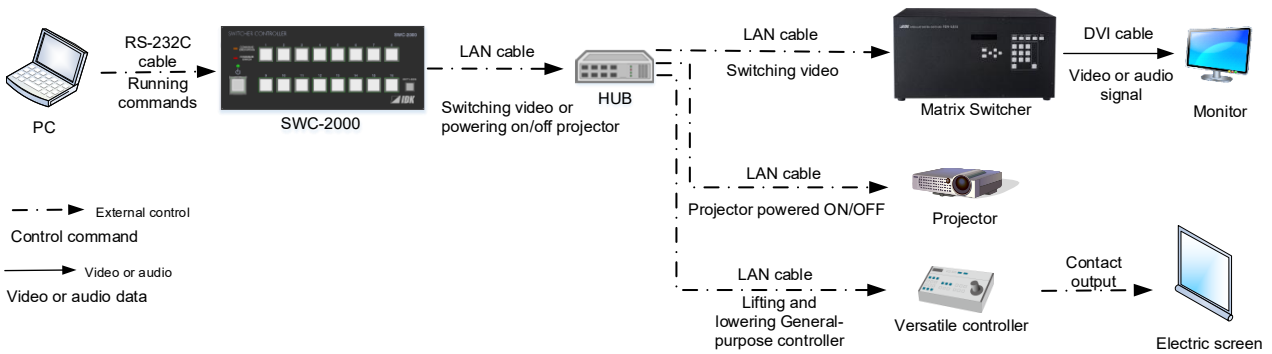

[Fig. 3.2] System configuration

Tip:

JavaScript is used for SWC-2000's WEB browser. If setting the SWC-2000 using a WEB browser, make sure to enable JavaScript of the WEB browser by referring to the HELP of each WEB browser.

4 Features

- Control system management
 - Powers on/off projectors, switches video of matrix switchers, and so on.

- Remote control using a WEB browser
 - Switches the SWX-2000's power on/off and executes control commands.

- Control output
 - Controls external devices via RS-232C and LAN
 - Outputs control command
 - (Controls matrix switchers, multiple switchers, and projectors)
 - Supports PJLink

- Other features
 - Powers off using the Standby button
 - Key lock
 - Backs up and restores all settings
 - Rack and tabletop mountable

【See: 2 Rack mount kit】

【See: 7.2 Powering ON/OFF】

【See: 7.8 Key lock】

【See: 9.14 BACKUP / RESTORE menu】

5 Front and Rear panels

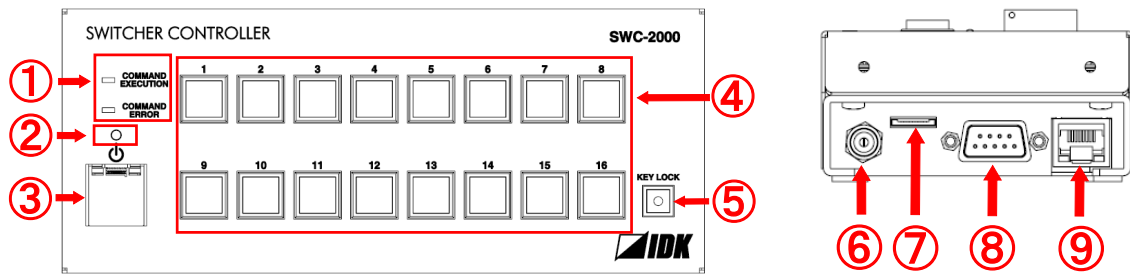

[Fig. 5.1] Panel drawings

[Table 5.1] Part names and descriptions

Number	Part name	Description
①	Control status LED	<ul style="list-style-type: none"> COMMAND EXECUTION Blinks in orange: Control commands are being executed. Does not light : No commands are executed. COMMAND ERROR Blinks in orange: An error occurs while control commands are sent or received. Does not light : No error occurs. <p style="text-align: right;">【See: 7.6 Control status LED】</p>
②	Power status LED	<p>Lights in green : Powered on. Lights in orange : Powered off.</p>
③	Standby button	<p>Powers on/off the SWC-2000. Lights in green : Powered on. Does not light : Powered off.</p> <p style="text-align: right;">【See: 7.2 Powering ON/OFF】</p>
④	Control command button (1 to 16)	<p>Executes control commands 1 to 16.</p> <p style="text-align: right;">【See: 9.10 COMMAND LINK menu】</p>
⑤	KEY LOCK button	<p>Locks/releases Standby button and control command buttons. Lights in green : Being locked. Does not light : Not locked.</p> <p style="text-align: right;">【See: 7.8 Key lock】</p>
⑥	Power connector	For provided AC adapter with screw-type lock.
⑦	Maintenance connector	For maintenance. Do not use.
⑧	RS-232C port	For controlling external devices using commands.
⑨	LAN port	For controlling external devices using commands or WEB browser.

6 Connecting to External device

6.1 Preparations

Prepare a LAN cable or RS-232C cable before connecting to external devices.

6.2 Precautions

Follow the instructions below when installing the SWC-2000.

■ Installation

- Before connecting a cable to the SWC-2000 or an external device that is connected to the SWC-2000, touch a ground metal to remove electricity from your body.
- Do not place the SWC-2000 on top of another one.
- Prepare ventilating equipment to keep the ambient temperature at 40 degrees C/104 degrees F or less. If inadequately vented, the life of parts may be shortened and operations may be affected.

■ Attaching and removing AC plug

The shapes of AC plugs with screw-type lock differ from country to country. Use the appropriate AC plug. Contact us if you have any questions.

Removing AC plug:

Slide the AC plug (②) from the AC adapter while holding down the portion mentioned below (①).

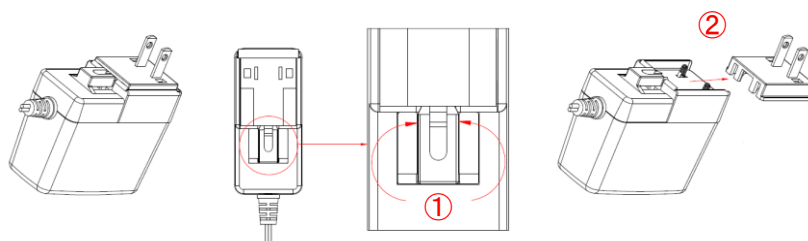

[Fig. 6.1] Removing AC plug

Attaching AC plug:

Gently slide the AC plug into the AC adapter (③) until it clicks (④).

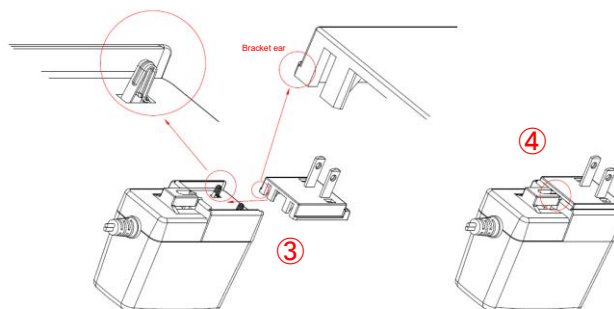

[Fig. 6.2] Attaching AC plug

6.3 Typical SWC-2000 applications

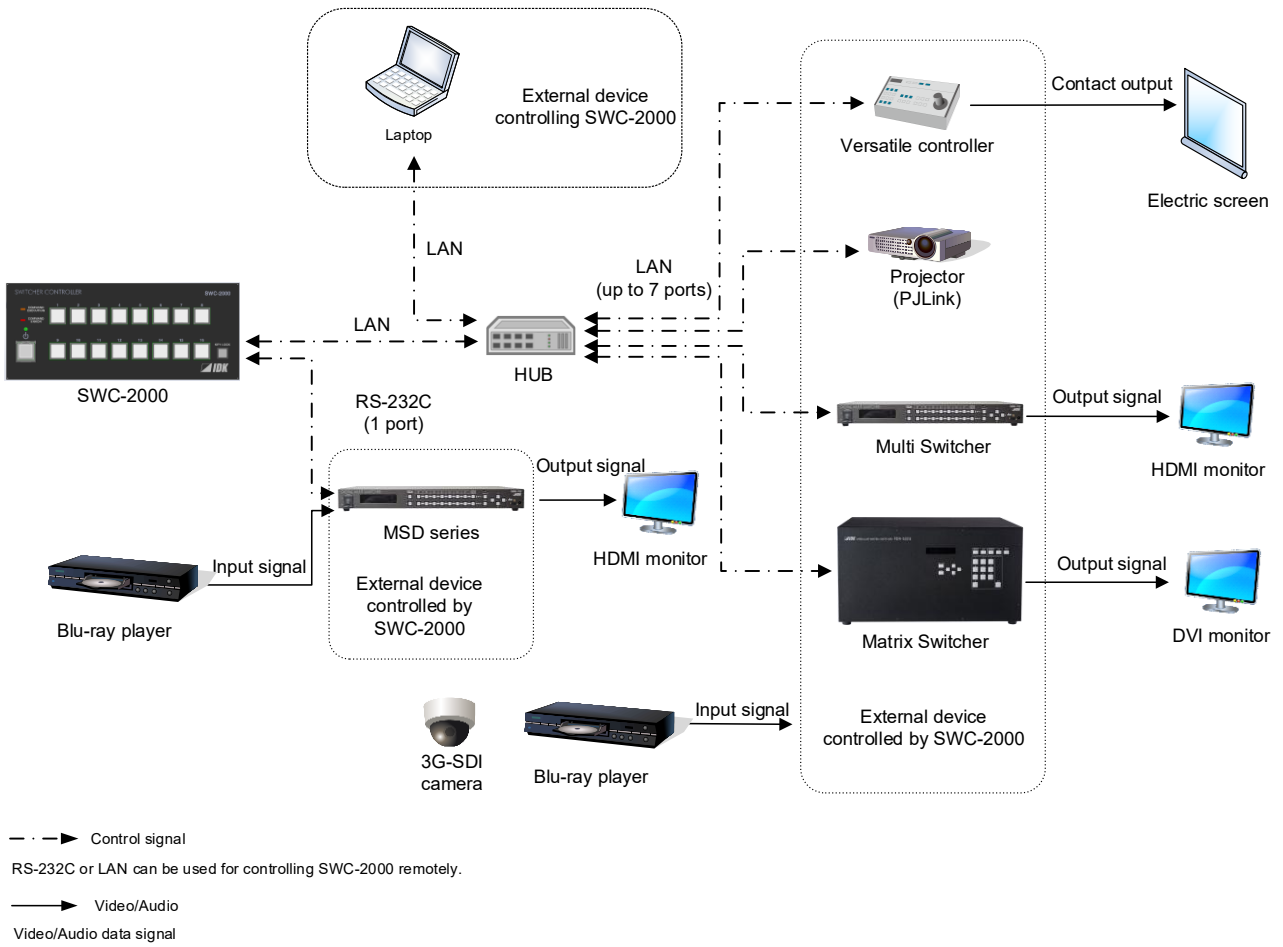

[Fig. 6.3] System application example

7 Basic operations

7.1 Starting SWC-2000

Two seconds after power is supplied from the AC adapter, the hardware will be initialized and the SWC-2000 can be operated.

7.2 Powering ON/OFF

Press the Standby button to power on/off the SWC-2000.

[Table 7.1] Settable functions when SWC-2000 is powered ON/OFF

Power	Functions can be used	Functions cannot be used
ON	All functions	None
OFF	Standby button, Control command execution while power-off, remote operation (WEB browser, control command)	Control command buttons 1 to 16, KEYLOCK button

【See: 9.10.2 TOGGLE and COMMAND (Linking control command)】

7.3 Rebooting

Control commands assigned to power-on and power-off operations are not executed when the SWC-2000 is rebooted.

1. Press the “KEYLOCK” button to lock control command buttons.
2. Press the Standby button, Control command “8” button, and Control command “9” button at the same time for three seconds.
3. The SWC-2000 reboots.

【See: 7.8 Key lock】

7.4 Power-on (supplied from AC adapter) status

You can set the status for when power is supplied from the AC adapter using a WEB browser by referring to “9.15.2 POWER ON SETTING STANDBY BUTTON”.

【See: 9.15.2 POWER ON SETTING STANDBY BUTTON】

7.5 Initializing

You can initialize settings to factory default:

1. Press the following three buttons at the same time and supply power from the AC adapter.
"KEYLOCK" button, Control command "6" button, and Control command "13" button
2. Press these buttons until you hear beep sound (three seconds or longer).
3. The SWC-2000 reboots and starts with factory default settings.

Note:

Once settings are initialized, control command and other settings are also deleted. Set them again as needed.

7.6 Control status LEDs

You can check current control status with the control status LEDs.

COMMAND EXECUTION

LED blinks in orange: Control commands are being executed.

LED does not light: No control commands are executed.

COMMAND ERROR

LED blinks in orange: Timeout between the SWC-2000 and controlled device occurs or an error of IDK or PJLink product is replied.

See the table below for details

LED does not light: No error occurs.

[Table 7.2] COMMAND ERROR LED

REPLY COMMAND LINK	REPLY DISPLAY	COMMAND ERROR LED blinks
Disabled	Disabled	Only when an error occurs in IDK or PJLink product.
Disabled	Enabled	When an error occurs in IDK or PJLink product When timeout occurs
Enabled	Disabled	Only when timeout occurs

See each section for settings of REPLY COMMAND LINK and REPLY DISPLAY.

【See: 9.6.2 Setting control command】

【See:9.6.3 LINK button】

7.7 Executing control commands

Control commands can be executed when a control command button or the Standby button is pressed.

For control command buttons: Normally, only PLANE A's control commands are executed, but commands of PLANE A and PLANE B can be executed alternately by enabling the toggle operation.

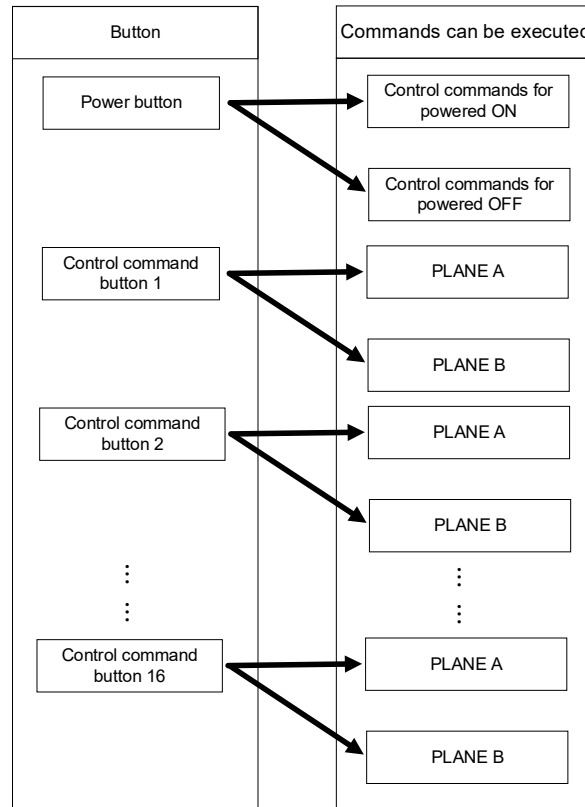

Each control command button has PLANE A and PLANE B.

[Fig. 7.1] Executing control commands

You can set control commands using commands or WEB pages.

【See: Command Guide】

【See: 9.10 COMMAND LINK menu】

7.8 Key lock

You can lock and unlock buttons to prevent operational mistakes.
The LED of the KEY LOCK button lights when a button is locked.

[Table 7.3] Key lock

Function	Buttons to be locked	Buttons not to be locked
1. Locking for only control command buttons	Control command buttons 1 to 16	Standby button, Remote operations (WEB browser, control commands)
2. Locking for all buttons	All buttons*	Remote operations (WEB browser, control commands)

*Only the KEY LOCK button is available for unlocking buttons.

【See:9.15.4 AUTO LOCK】

- Locking for only control command buttons:
 For locking: Press the KEY LOCK button.
 For unlocking: Press the KEY LOCK button while control command buttons are locked.

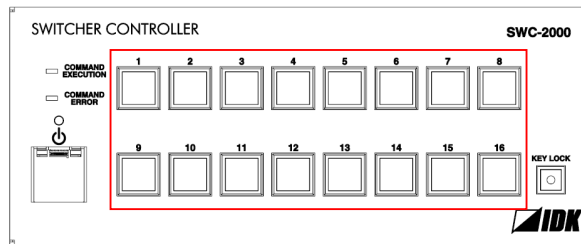

[Fig. 7.2] Buttons to be locked (Control command button)

- Locking for all buttons:
 For locking: Press the KEY LOCK button for about two seconds.
 For unlocking: Press the KEY LOCK button for about two seconds while buttons are locked.

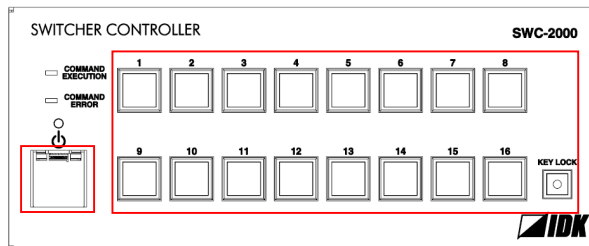

[Fig. 7.3] Buttons to be locked

8 How to use SWC-2000

Set the SWC-2000 using commands or WEB browser by referring to the Command Guide or WEB menu, respectively.

Note:

The SWC-2000 does not support automatic acquisition of IP address using DHCP (Dynamic Host Configuration Protocol). If you use the SWC-2000 in a network with DHCP, keep a static IP address. If controlling peripheral devices connected over LAN from the SWC-2000, keep several static IP addresses.

【See: Command Guide】

【See: 9 WEB menu】

8.1 Application example

Example:

Before using the SWC-2000, you set it using a WEB browser as follows.

- Remote switching channel: Video and audio that are input from matrix switcher's IN1 are output from all outputs by pressing Control command button1.

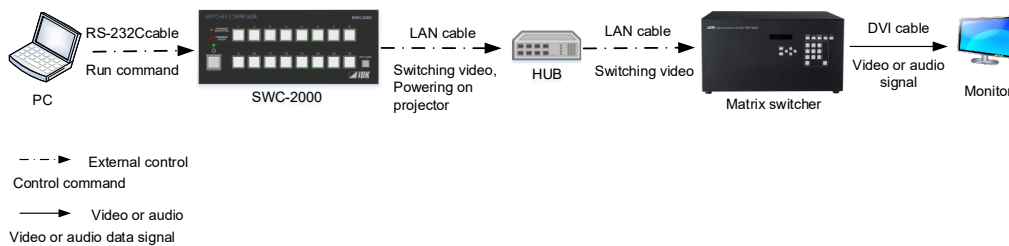

[Fig. 8.1] Application

[Table 8.1] Setting for matrix switcher

IP address	Port number
192.168.1.100	1100

8.1.1 Preparation for LAN connection

First prepare LAN connection and then set “8.1.2 Setting SWC-2000”.

1. Connect a PC to the SWC-2000 via a LAN cable
2. Set the PC's static IP address. (e.g. “192.168.1.10”)
3. Edit the SWC-2000's IP address. **Default: “192.168.1.199”**.

8.1.2 Setting SWC-2000

1. Start the WEB browser program (e.g. Microsoft Internet Explorer)
2. Enter “http://(SWC-2000’s IP address)/lancom.html” in the browser’s Address field. When LAN communication is established, the communication setting page is displayed.
3. Default IP address is “192.168.1.199”

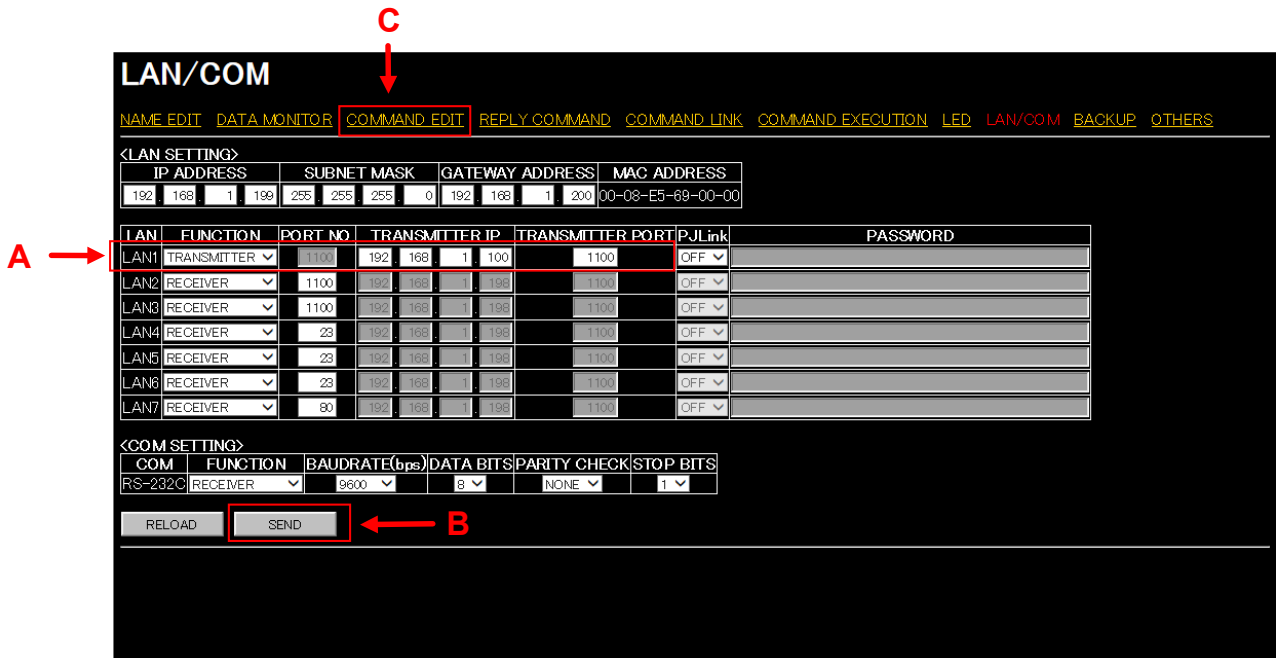

[Fig. 8.2] Communication setting page

4. Enter the following values for matrix switcher, as an example, into the LAN1 row (A).

[Table 8.2] LAN1 setting example

Item	Value	Description
FUNCTION	TRANSMITTER	Transmitter mode
TRANSMITTER IP	192.168.1.100	Matrix switcher's IP address
TRANSMITTER PORT	1100	Matrix switcher's port number

5. Click the “SEND” button (B) to change the setting. When settings are changed, connections with a WEB browser may be disconnected. In that case, enter “http://(SWC-2000’s IP address)/lancom.html” into the address bar again to confirm the settings are applied correctly.
6. Click “COMMAND EDIT” (C) to display the following command list menu.

【See: 9.13 LAN / COM menu】

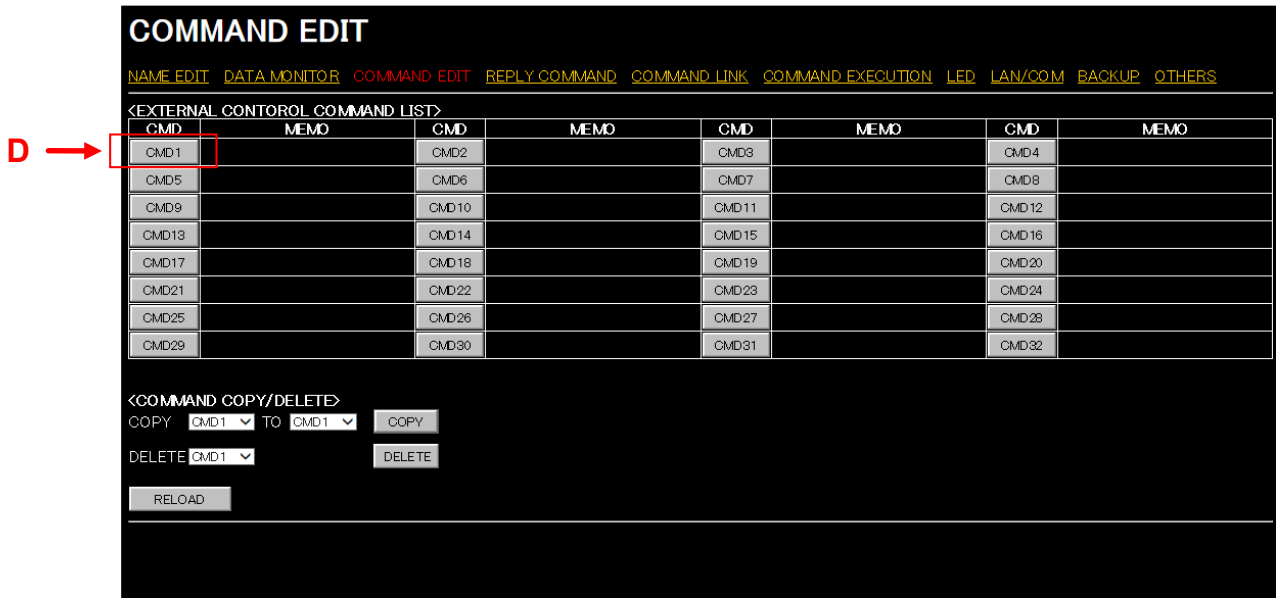

[Fig. 8.3] Control command list

- Click the “CMD1” button (D) to edit control command 1 in the following advanced setting page for control command.

【See: 9.5 COMMAND EDIT menu (Control command list)】

【See: 9.6 COMMAND EDIT menu (Advanced setting of control command)】

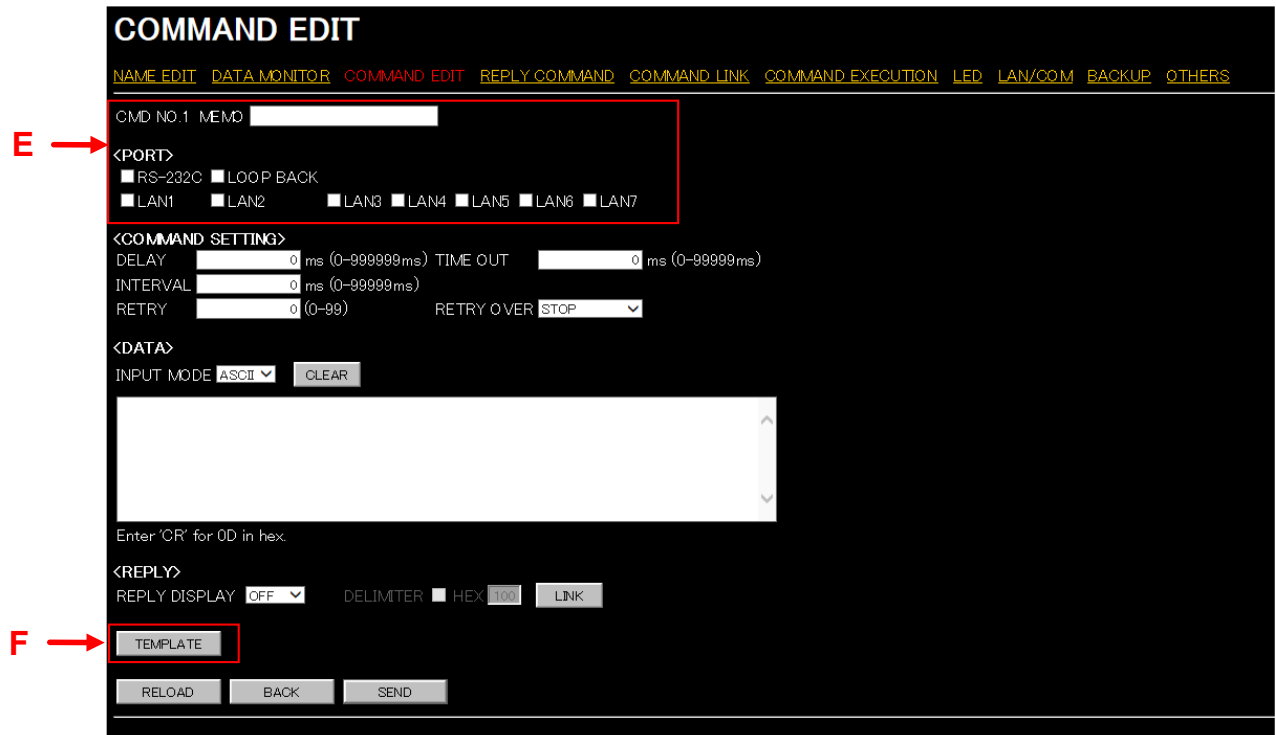

[Fig. 8.4] Advanced setting page for control command

8. Enter the following values in the (E) area.

[Table 8.3] Setting values for control command

Item	Value	Description
MEMO	CH1	Desired one-byte alphabet and numbers (up to 14 characters)
<PORT>	Tick "LAN1".	Using settings of LAN1 when sending control command.

9. Click the "TEMPLATE" button to display the following template page.

【See: 9.5 COMMAND EDIT menu (Control command list)】

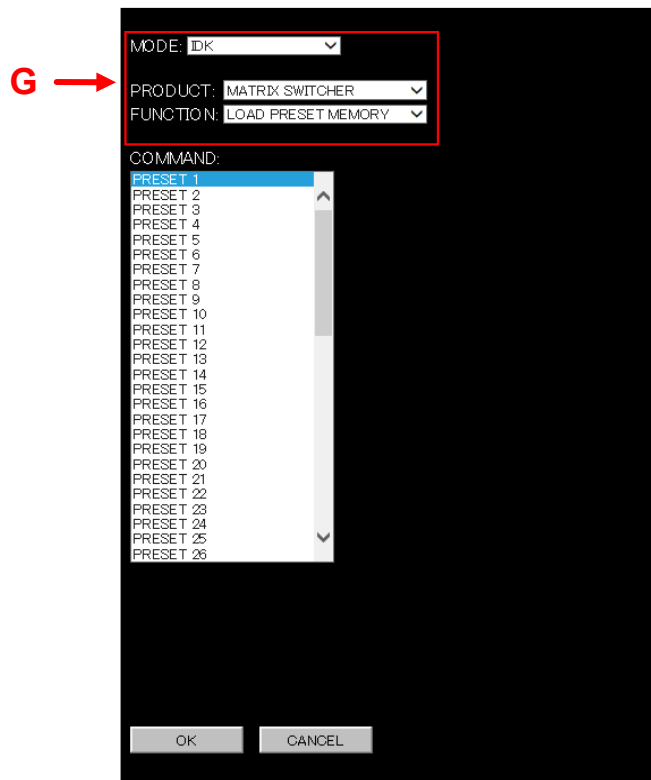

[Fig. 8.5] Template

10. Set the template as below in (G) to switch video and audio of the matrix switcher.

[Table 8.4] Setting values for template

Item	Value	Description
MODE	IDK	Control command display mode for IDK products
PRODUCT	MATRIX SWITCHER	Matrix switcher mode.
FUNCTION	CHANNEL SELECT (V+A)	Control command setting mode for switching video and audio of matrix switcher

11. After template is set, the following page (H) is displayed. Input channel numbers and output channel numbers are displayed in the left and right sides, respectively. Register the switching control command: outputs video and audio that are input from matrix switcher's IN1 to all outputs. After selecting "IN1" and "ALL" for input channel number and output channel number, respectively, click the "OK" button (I).

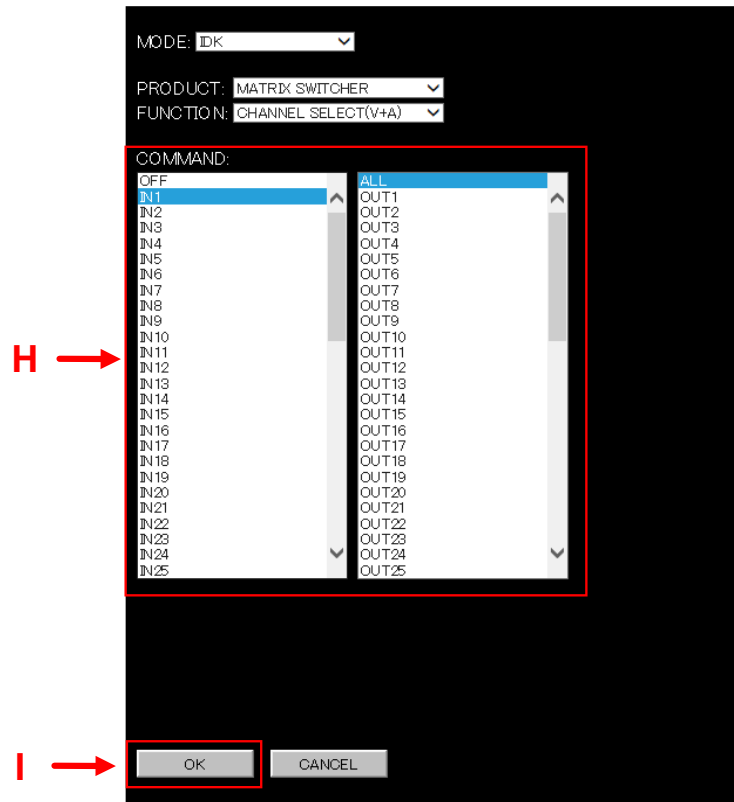

[Fig. 8.6] Switching video and audio

- The template page disappears and the control command that is selected in the template is entered in the "<DATA>" box (J). Make sure that the control command is entered. Click the "SEND" button (K) to apply the setting to the SWC-2000.
- Click "COMMAND LINK" (L).



[Fig. 8.7] After control command is set

- The following WEB menu for control command link is displayed.
Click the desired control condition number (M).
Example: Linking the control command to Control command button 1 → Click “1”.

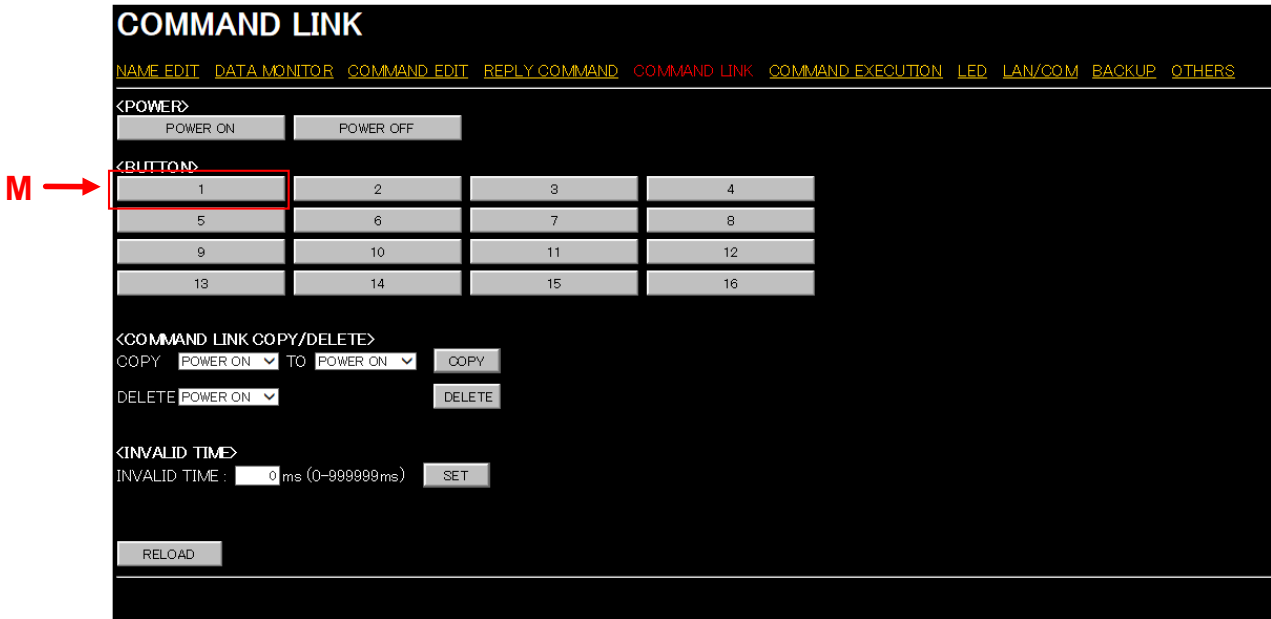

[Fig. 8.8] Control command link

【See: 9.9 COMMAND LINK menu (Selecting button)】

- The control command link (advanced setting) page is displayed.
Select “CMD1:CH1” (N).

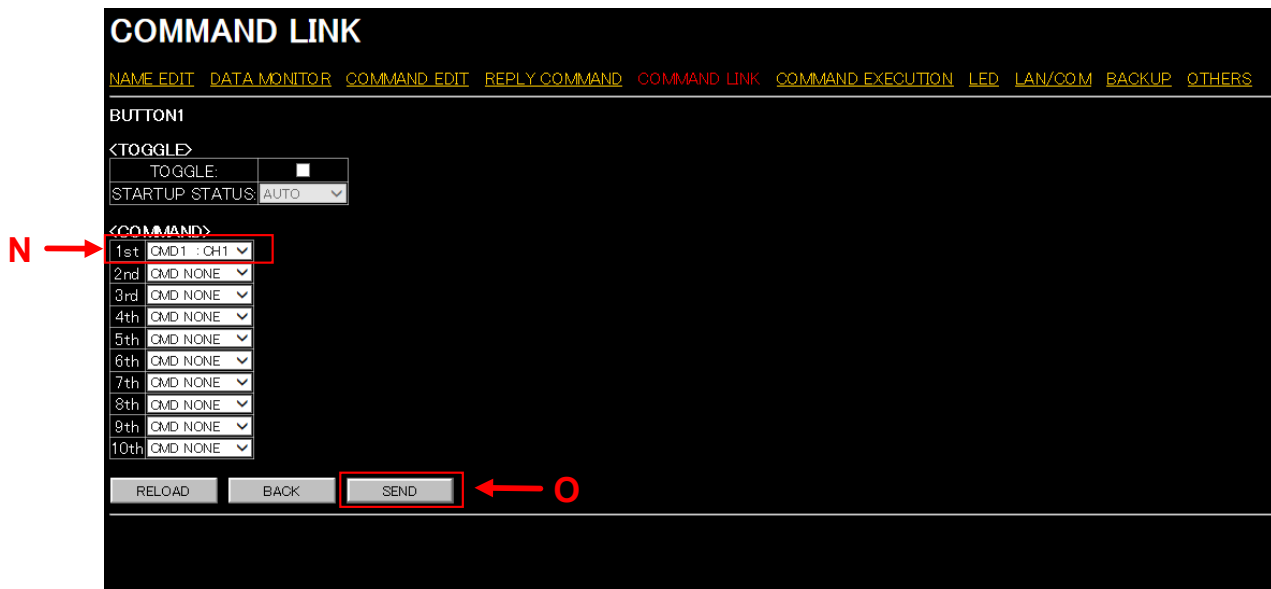

[Fig. 8.9] Control command link (advanced setting)

- Click the “SEND” button (O) to link the control command.

【See: 9.10 COMMAND LINK menu】

Now setting a control command to the SWC-2000 is complete.

8.2 Controlling external device from SWC-2000

Three following methods are available to control external devices using control commands registered in the SWC-2000.

- Using control command buttons
- Using WEB browser
- Using control commands (Refer to “SWC-2000 Command Guide”.)

8.2.1 Control from control command buttons

The control commands are sent to external devices by pressing the desired control command button that is linked to the control command.

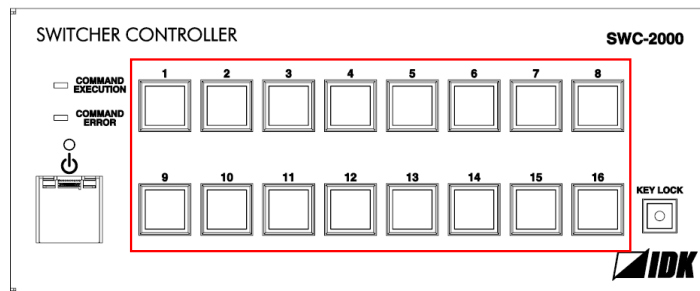

[Fig. 8.10] Control command buttons

8.2.2 Control from WEB browser

Procedure for controlling from WEB browser:

1. Start the WEB browser program (e.g. Microsoft Internet Explorer).
2. Enter “http://(SWC-2000’s IP address)” into the address bar. When LAN communication is established, the MAIN menu is displayed.
3. Click the desired command button of the WEB browser to send the control command to external devices.

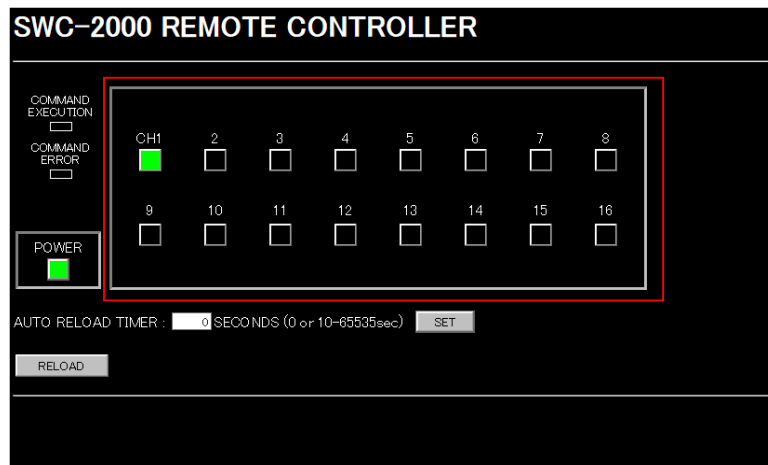

[Fig. 8.11] Control from WEB browser

[See: 9.2 MAIN menu]

9 WEB menu

9.1 About WEB menu

The WEB menu is divided into two settings, for operation and for setting, and their procedures differ from each other.

After setting the SWC-2000, it can be operated remotely only using menu for operation.

Menu for operation

Enter "http://(SWC-2000's IP address)" into the address bar.

Menu for setting

Enter "http://(SWC-2000's IP address)/ *****.html" into the address bar.

*****: Depends on WEB menus.

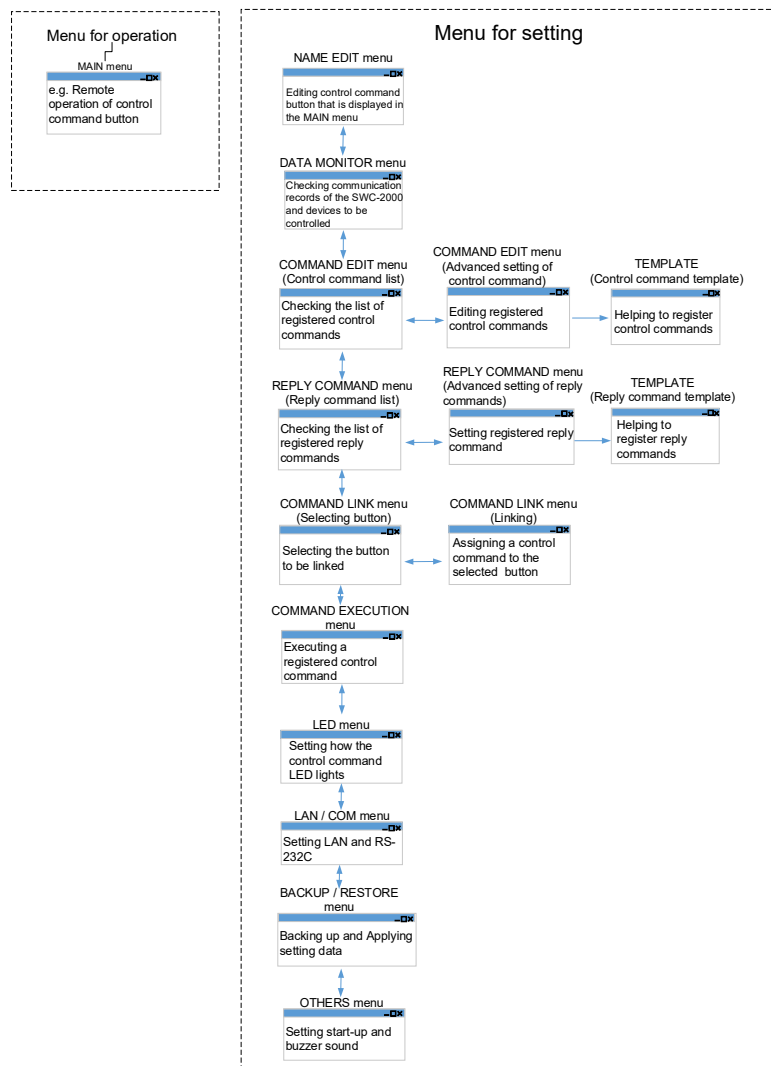

[Fig. 9.1] WEB menu

9.2 MAIN menu

You can display the MAIN menu by entering “http://(SWC-2000’s IP address)” into the address bar. This menu is for operating the Standby button (②) and control command buttons (③). Power and control commands can be executed from a WEB browser.

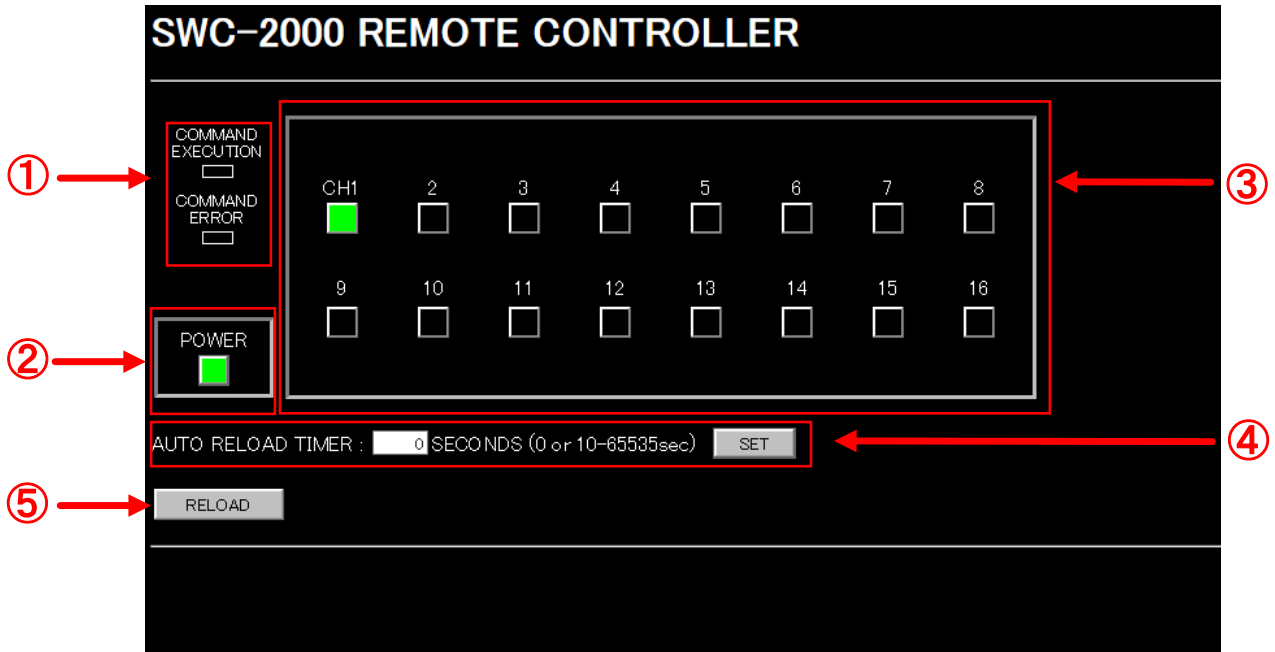

[Fig. 9.2] MAIN menu

- ① Control status
- ② Control status boxes
- ③ Control command button
- ④ AUTO RELOAD TIMER
- ⑤ RELOAD button

9.2.1 Control status boxes

Show the current control status.

- COMMAND EXECUTION lights in orange while the SWC-2000 executes a control command for external device.
- COMMAND ERROR lights in orange if timeout between the SWC-2000 and controlled device occurs or if an error of IDK or PJLink product is replied.

【See: 7.6 Control status LED】

9.2.2 Standby button

Powers on and off the SWC-2000.

- Green: Operation mode
- Black : Standby mode

9.2.3 Control command buttons

Operate the control command buttons.

Numbers displayed on top of control command button can be changed from “**9.3 NAME EDIT menu**”.

Button colors:

- Green : An executable control command is linked.
- Orange : An executable control command is linked. (PLANE B) *
- Black : No executable control command is linked.

* Only when “TOGGLE” of each control command is selected.

【See: 9.3 NAME EDIT menu】

【See: 9.10.2 TOGGLE and COMMAND (Linking control command)】

9.2.4 AUTO RELOAD TIMER

Updates the WEB menu automatically and displays it on the WEB browser.

Enter the desired number of seconds (10 to 65535) into the “AUTO RELOAD TIMER” field.

- 0: Does not update [Default]
- 10 to 65535 seconds

Click the SET button to apply the setting.

9.2.5 RELOAD button

Reloads the displayed WEB menu and displays it on the WEB browser.

Click the “RELOAD” button.

9.3 NAME EDIT menu

You can display the NAME EDIT menu by entering “http://(SWC-2000’s IP address)/nameedit.html” into the address bar.

This menu is for editing the name of control command button.



[Fig. 9.3] NAME EDIT menu

- ① WEB menu link
- ② BUTTON NAME EDIT
- ③ RELOAD button
- ④ SEND button

9.3.1 WEB menu links

Jump to the selected Web menu.
Click the desired link.

9.3.2 BUTTON NAME EDIT

Edits names of control command buttons displayed on the MAIN menu.
Type the desired name (Up to 10 one-byte alphabet and numbers) directly into boxes 1 to 16 to change the name and click the "SEND" button.

【See: 9.2 MAIN menu】

9.3.3 RELOAD button

Reloads the displayed WEB menu and displays it on the WEB browser.
Click the "RELOAD" button.

9.3.4 SEND button

Registers the name of control command button.
Click the "SEND" button.

9.4 DATA MONITOR menu

You can display the DATA MONITOR menu by entering “http://(SWC-2000’s IP address)/ datamonitor.html” into the address bar.

This menu is for displaying communication history of sent and received control commands.

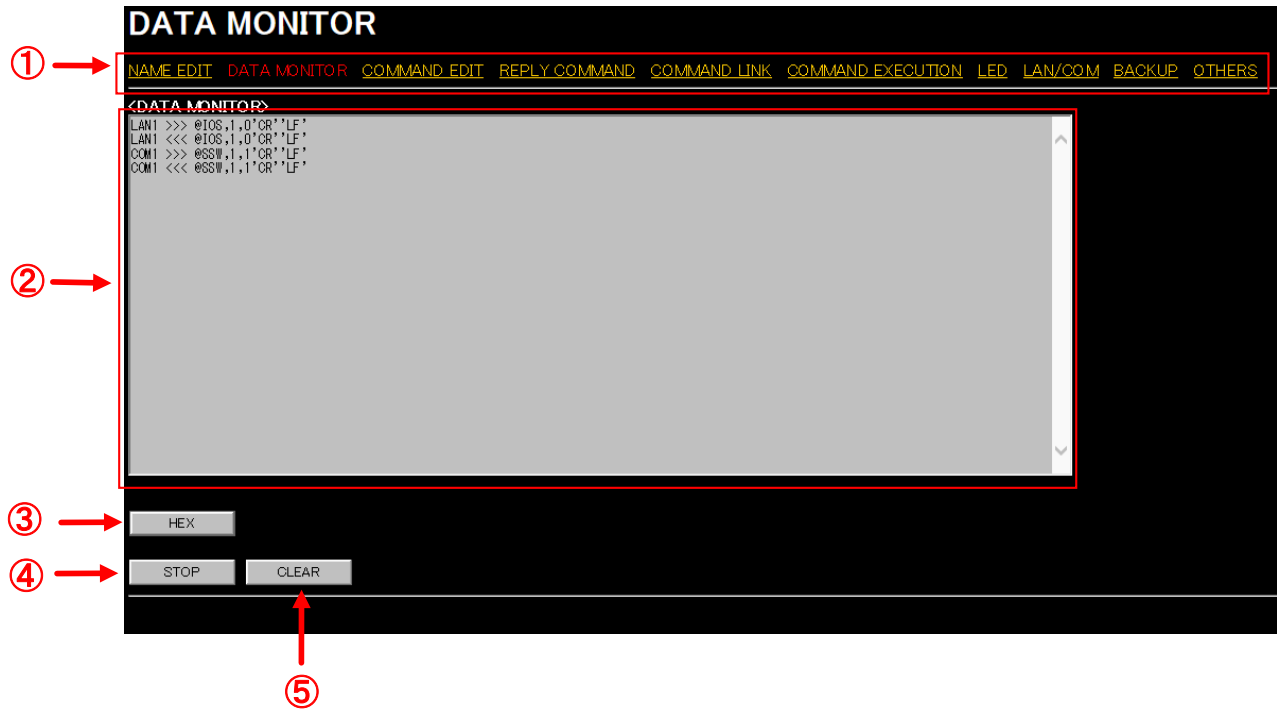

[Fig. 9.4] DATA MONITOR menu

- ① WEB menu
- ② DATA MONITOR
- ③ HEX / ASCII button
- ④ STOP / RUN button
- ⑤ CLEAR button

9.4.1 WEB menu links

Jump to the selected Web menu.
Click the desired link.

9.4.2 DATA MONITOR

Shows the communication histories of sent control commands and received reply commands for LAN1 to LAN7 and RS-232C.

9.4.3 HEX / ASCII button

Switches HEX/ASCII.
Click the HEX button or ASCII button.



[Fig. 9.5] Displays in HEX or ASCII

9.4.4 STOP / RUN button

Stops or starts automatic updating of DATA MONITOR menu.

STOP: Stops the automatic updating temporarily.

RUN : Restarts the automatic updating.



[Fig. 9.6] For automatic updating

9.4.5 CLEAR button

Deletes communication histories of sent control commands and received reply commands.
Click the "CLEAR" button.

9.5 COMMAND EDIT menu (Control command list)

You can display the COMMAND EDIT menu by entering “http://(SWC-2000’s IP address)/commandedit.html” into the address bar.

Click the command number button you want to edit to jump to the COMMAND EDIT menu.

COMMAND EDIT

NAME EDIT DATA MONITOR COMMAND EDIT REPLY COMMAND COMMAND LINK COMMAND EXECUTION LED LAN/COM BACKUP OTHERS

<EXTERNAL CONTROL COMMAND LIST>

CMD	MEMO	CMD	MEMO	CMD	MEMO	CMD	MEMO
CMD1	CH1	CMD2		CMD3		CMD4	
CMD5		CMD6		CMD7		CMD8	
CMD9		CMD10		CMD11		CMD12	
CMD13		CMD14		CMD15		CMD16	
CMD17		CMD18		CMD19		CMD20	
CMD21		CMD22		CMD23		CMD24	
CMD25		CMD26		CMD27		CMD28	
CMD29		CMD30		CMD31		CMD32	

<COMMAND COPY/DELETE>

COPY CMD1 TO CMD1 COPY

DELETE CMD1 DELETE

RELOAD

[Fig. 9.7] COMMAND EDIT menu (Control command list)

- ① WEB menu links
- ② EXTERNAL CONTROL COMMAND LIST
- ③ COMMAND COPY / DELETE
- ④ RELOAD button

9.5.1 WEB menu links

Jump to the selected Web menu.
Click the desired link.

9.5.2 EXTERNAL CONTROL COMMAND LIST

Edits control commands 1 to 32.

Click the desired CMD button to open the advanced setting page.

Notes entered in “9.6 COMMAND EDIT menu (Advanced setting of control command)” are displayed in the “MEMO” field.

【See: 9.6 COMMAND EDIT menu (Advanced setting of control command)】

9.5.3 COMMAND COPY / DELETE

Copies and deletes registered control commands.

For copying : Select the desired CMD numbers and click the “COPY” button.

For deleting : Select the desired CMD number and click the “DELETE” button.

Example: COPY

A control command registered in CMD1 will be copied to CMD10 when the “COPY” button is clicked.



[Fig. 9.8] Copy

Example: DELETE

A control command registered in CMD1 will be deleted when the “DELETE” button is clicked.



[Fig. 9.9] Delete

9.5.4 RELOAD button

Reloads the displayed WEB menu and displays it on the WEB browser.

Click the “RELOAD” button.

9.6 COMMAND EDIT menu (Advanced setting of control command)

You can display the COMMAND EDIT menu by clicking the desired CMD button.



[Fig. 9.10] COMMAND EDIT menu (Advanced setting of control command)

- ① WEB menu
- ② Setting control command
- ③ LINK button
- ④ TEMPLATE button
- ⑤ RELOAD button
- ⑥ BACK button
- ⑦ SEND button

9.6.1 WEB menu links

Jump to the selected Web menu.
Click the desired link.







9.6.2 Setting control command

You can set control commands by setting the following items.

[Table 9.1] Setting control command

Item		Description	Setting value
MEMO		Register up to 14 characters as a note. The registered note is displayed on the control command list.	20 to 7D in ASCII codes except for 2C (,)
<PORT> (Communication port)		Select communication port that sends control commands The port can be set separately, and communication commands can be sent to multiple communication ports at the same time. <ul style="list-style-type: none"> • RS1: RS-232C CH1^{*1} • LOOP BACK: Internal loop back • LAN1 to LAN7: LAN connection 1 to 7^{*2} 	<div style="background-color: black; color: white; padding: 2px; display: inline-block;"><input type="checkbox"/> RS-232C</div> Not ticked: Does not send [Default] <div style="background-color: black; color: white; padding: 2px; display: inline-block; margin-top: 5px;"><input checked="" type="checkbox"/> RS-232C</div> Ticked: Sends
<COMMAND SETTING>	DELAY	Set the waiting time of the control command. Use this item for devices such as projectors that requires time to cool down after powering off.	"0" ms to "999999" ms [Default]: 0 ms
	TIME OUT ^{*3*4}	Set the timeout time for reply command to a sent command. If you do not use the function, set this item to "0".	"0" ms to "99999" ms [Default]: "0" ms
	INTERVAL for retry ^{*3*4}	Set the retry interval to resend the command.	"0" ms to "99999" ms [Default]: "0" ms
	RETRY (the number of retries) ^{*3*4}	Set the number of retries to resend the same command again if no valid response is replied.	"0" to "99" times [Default]: "0"
	RETRY OVER (when a retry error occurs) ^{*3}	Set whether the next command is to be executed or not if no valid response is replied, even after completing retry for the set number of retries.	STOP: Stops control command [Default] EXEC: Continues control commands

[Table 9.2] Setting control command (Cont'd)

Item		Description	Setting value
<DATA>	INPUT MODE (Input mode of sent command data)	Set the input mode of sent command data. Select "ASCII" if "DATA" of "COMMAND" consists of only 0A, 0D, and 20 to 7D of ASCII codes. Select "HEX" if "DATA" of "COMMAND" includes other codes.	ASCII [Default] HEX
	SIZE	Set the number of bytes to be sent starting with the first byte. Selectable only if "INPUT MODE" is set to "HEX".	"0" to "30" "0" [Default]
	DATA (Sent command data)	Set the command from the first byte according to the number of bytes set in "COM SIZE" (up to 30 bytes).	0A, 0D, 20 to 7D in ASCII, 00 to FF in hex [Default]: 20 (space)
<REPLY>	REPLY DISPLAY (Checking received data) ^{*5}	Select "ASCII" or "HEX" to check the timeout for when an error occurs in IDK products and PLink.	OFF: Does not check [Default] ASCII: Checks in ASCII HEX: Checks in hex
	DELIMITER (Checking delimiter) ^{*5}	Check the "DELIMITER" box and specify the desired value to check the delimiter which is sent at the very last of the received data. If you uncheck the box, all received data within the time that is set for "TIME OUT" will be effective. If you check the box, received data including delimiter will be effective.	 "DELIMITER" will not be checked. [Default] All received data is valid.  "DELIMITER" will be checked. ("00" to "FF" in hex)
	REPLY COMMAND LINK ^{*3*6}	Set a possible reply command to the sent command. Click the "LINK" button to open the <REPLY COMMAND LINK> page.	  Not checked. [Default]   Checked

*1 If "RS-232C" is set to "ON", RS-232C needs to be set to "TRANSMITTER" in "9.13 LAN / COM menu".

*2 If you set commands to be output from LAN1 to LAN7, set "LAN/COM" to "TRANSMITTER".

*3 If "REPLY COMMAND LINK" is set to "Not checked", this item does not need to be set.

*4 If only "LOOP BACK" is sent, this item does not need to be set.

*5 If "REPLY DISPLAY" is set to "OFF", this item does not need to be set.

*6 If "REPLY DISPLAY" is set to "ASCII" or "HEX", this item cannot be set.

■ Loop back function

The SWC-2000 sends a communication command back to the SWC-2000 itself using the loop back function. It replies “OK” if processed normally while replying “NG” if parameter or command is incorrect. To check the reply command, set reply command 31 and 32 to “CHECK”.

Example: “INPUT MODE” is set to “ASCII”.



[Fig. 9.11] Input box of control command (in ASCII)

For special characters in ASCII, use the characters in the following table.

[Table 9.3] Special characters

HEX	ASCII	HEX	ASCII
00	'NUL'	11	'DC1'
01	'SOH'	12	'DC2'
02	'STX'	13	'DC3'
03	'ETX'	14	'DC4'
04	'EOT'	15	'NAK'
05	'ENQ'	16	'SYN'
06	'ACK'	17	'ETB'
07	'BEL'	18	'18'
08	'BS'	19	'EM'
09	'HT'	1A	'SUB'
0A	'LF'	1B	'ESC'
0B	'VT'	1C	'FS'
0C	'0C'	1D	'GS'
0D	'CR'	1E	'RS'
0E	'S0'	1F	'US'
0F	'SI'	7F	'DEL'
10	'DLE'		

Example: "INPUT MODE" is set to "HEX".

INPUT MODE		HEX	CLEAR												
SIZE	8														
1	2	3	4	5	6	7	8	9	10	11	12	13	14	15	
40	52	50	4D	2C	31	0D	0A	20	20	20	20	20	20	20	
16	17	18	19	20	21	22	23	24	25	26	27	28	29	30	
20	20	20	20	20	20	20	20	20	20	20	20	20	20	20	

[Fig. 9.12] Input box of control command (in HEX)

9.6.3 LINK button

Links reply commands.

Click the “LINK” button to open the page for setting reply commands and select the desired command.

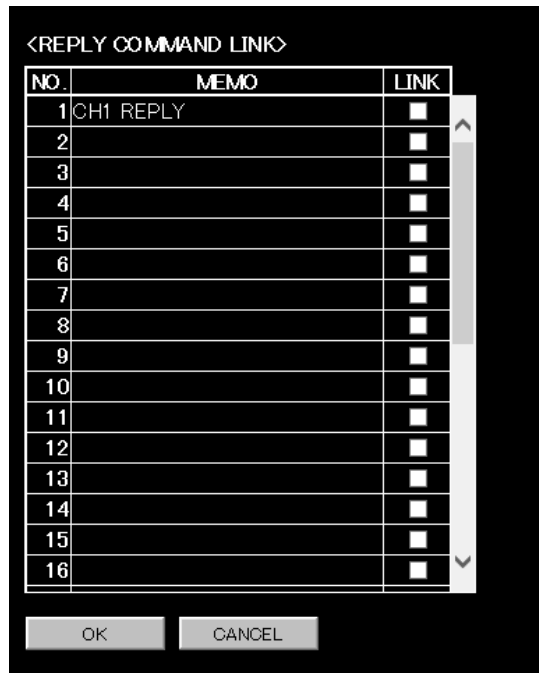

[Fig. 9.13] REPLY COMMAND LINK

Check the LINK box and click the “OK” button to determine if the reply command is returned when the control command is sent.

If a reply command is received you can cancel the control command, send another control command, or the like.

【See: 9.7 REPLY COMMAND menu (Reply command list)】

9.6.4 TEMPLATE button

Registers control commands only by switching “MODE”.

You can open the template by clicking the “TEMPLATE” button.

IDK’s control commands and PJLink commands are originally registered. You can register other commands directly.

【See: 10 Product specification】

【See: 9.6.2 Setting control command】

You can display buttons for inputting ASCII codes by selecting “ASCII” from the “MODE” in order to prevent incorrect input. (These buttons are displayed only if you set “INPUT MODE” to “HEX”.)

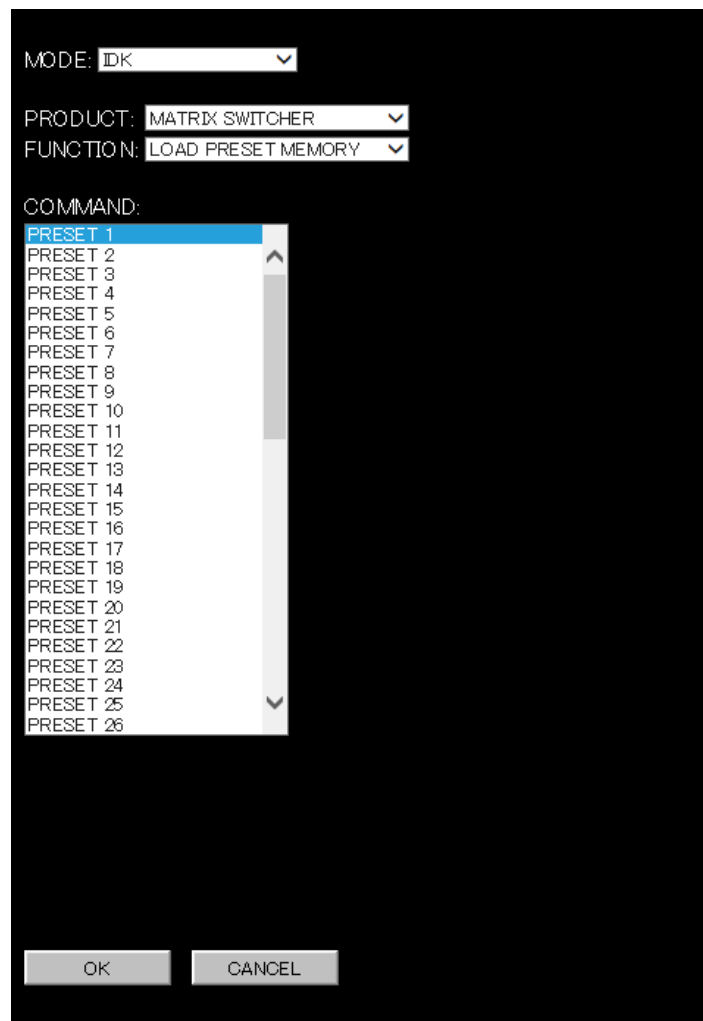

[Fig. 9.14] Input support for control commands

Control commands registered in the input support page supports commands for matrix switchers, multiple switchers, PJLink, and other products. The mode is switched depending on each product automatically.

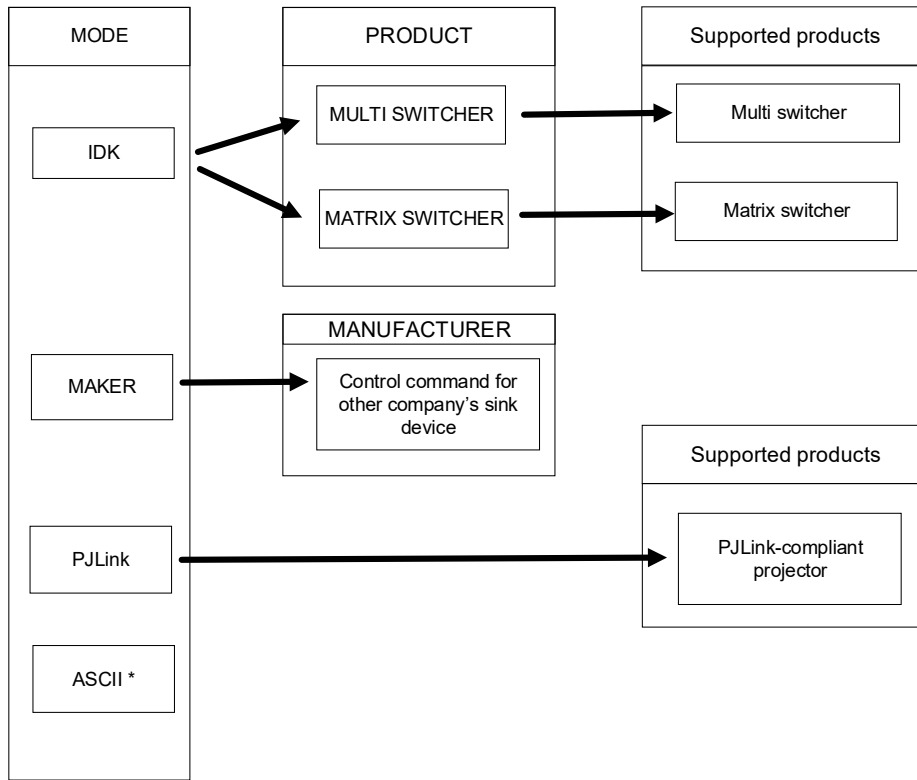

[Fig. 9.15] Supported products

[Table 9.4] MODE

MODE	Description
IDK	Displays control command's templates for matrix switchers and multiple switchers.
MAKER	Displays control command templates for other companies' sink device.
PJLink	Displays PJLink command's template.
ASCII *	Displays buttons for inputting ASCII codes.

* Displayed only if you set "INPUT MODE" to "HEX".

If you set “MODE” to “IDK”, the “PRODUCT” list is displayed.

1. Select the desired “PRODUCT” to display supported control commands on the “COMMAND” list.

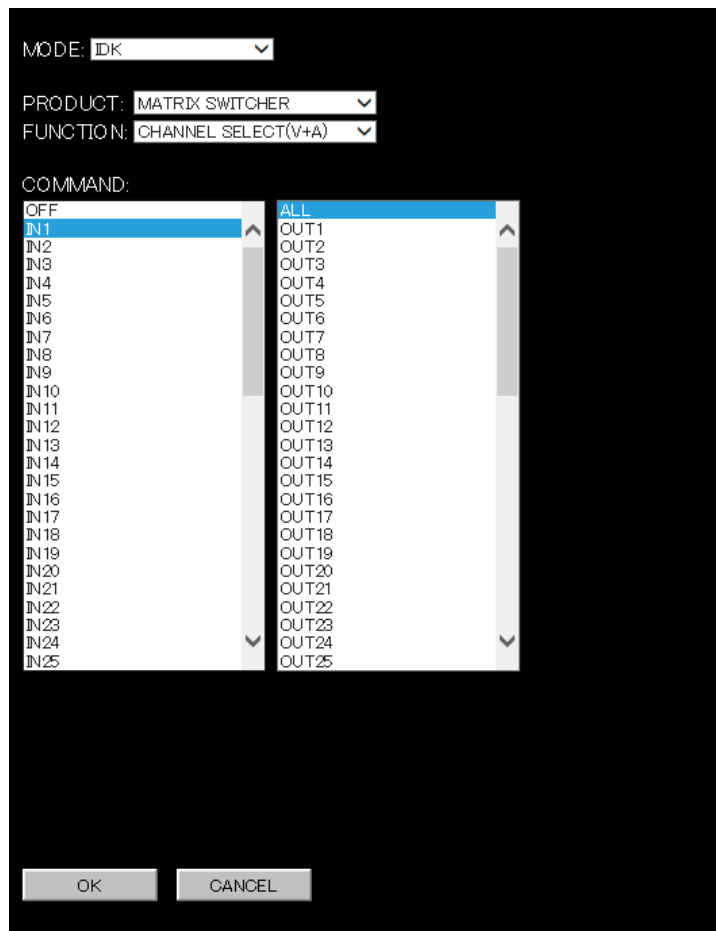

[Fig. 9.16] CHANNEL SELECT (V+A) template

2. Select the desired control command and click the “OK” button to apply it to “9.6 COMMAND EDIT menu (Advanced setting of control command)”.
3. The control command is entered on the field below mentioned in red.
4. Since you can set the “DATA” items from this template, you need to edit “PORT” and “MEMO” as needed.

5. When you finish setting, click the "SEND" button.



[Fig. 9.17] Control command has been input using input support

■ Setting PJLink

The SWC-2000 supports PJLink, which is a standard protocol to control projectors.

For “PORT”, select the LAN port which is used for PJLink protocol so that you can select PJLink command when entering “DATA”.

[Table 9.5] PJLink command (class1) list

No.	Command										Description
1	%	1	P	O	W	R	(SP)	0	(CR)		Power off (Standby)
2	%	1	P	O	W	R	(SP)	1	(CR)		Power on (Lamp on)
3	%	1	P	O	W	R	(SP)	?	(CR)		Get power status
4	%	1	I	N	P	T	(SP)	1	*1	(CR)	Switch input to RGB
5	%	1	I	N	P	T	(SP)	2	*1	(CR)	Switch input to VIDEO
6	%	1	I	N	P	T	(SP)	3	*1	(CR)	Switch input to DIGITAL
7	%	1	I	N	P	T	(SP)	4	*1	(CR)	Switch input to STORAGE
8	%	1	I	N	P	T	(SP)	5	*1	(CR)	Switch input to NETWORK
9	%	1	I	N	P	T	(SP)	?	CR		Get input selection settings
10	%	1	A	V	M	T	(SP)	1	0	(CR)	Switch off video mute
11	%	1	A	V	M	T	(SP)	1	1	(CR)	Switch on video mute
12	%	1	A	V	M	T	(SP)	2	0	(CR)	Switch off audio mute
13	%	1	A	V	M	T	(SP)	2	1	(CR)	Switch on audio mute
14	%	1	A	V	M	T	(SP)	3	0	(CR)	Video+audio mute off
15	%	1	A	V	M	T	(SP)	3	1	(CR)	Video+audio mute on
16	%	1	A	V	M	T	(SP)	?	(CR)		Get mute settings
17	%	1	E	R	S	T	(SP)	?	(CR)		Get error status
18	%	1	L	A	M	P	(SP)	?	(CR)		Get time and status of lamp
19	%	1	I	N	S	T	(SP)	?	(CR)		Get list of switching input
20	%	1	N	A	M	E	(SP)	?	(CR)		Get projector name
21	%	1	I	N	F	1	(SP)	?	(CR)		Get manufacture name
22	%	1	I	N	F	2	(SP)	?	(CR)		Get product name
23	%	1	I	N	F	O	(SP)	?	(CR)		Get other information (optional of manufacturer)

(SP): space; (CR): delimiter

*1: You can specify the input number from 1 to 9, but types and the number of selectable input connectors differ depending on the projector. “1” is displayed by default.

Reply command structure for PJLink commands:

The first 6 bites: the sent command data without change; the 7th bite: “=”; after the 8th bite: processing result PJLink specifications regulate that projectors are required to reply the reply commands within 2 seconds after receiving the PJLink command. However, some projectors have different specifications. Check the manual of your projector and apply the response time indicated in the manual if there is one listed.

[Table 9.6] Reply commands to PJLink command (class1)

No.	Command											Description	
1	%	1	x	x	x	x	=	O	K	(CR)		Terminated normally	
2	%	1	x	x	x	x	=	E	R	R	1	(CR)	Mistake in command itself (Undefined command)
3	%	1	x	x	x	x	=	E	R	R	2	(CR)	Invalid parameter
4	%	1	x	x	x	x	=	E	R	R	3	(CR)	Currently not acceptable
5	%	1	x	x	x	x	=	E	R	R	4	(CR)	Malfunction of projector

[Table 9.7] Reply commands to status query command

No.	Command											Description			
Reply command to power status commands															
1	%	1	P	O	W	R	=	0	(CR)			Stand by			
2	%	1	P	O	W	R	=	1	(CR)			Power ON			
3	%	1	P	O	W	R	=	2	(CR)			Cooling			
4	%	1	P	O	W	R	=	3	(CR)			Warming up			
Reply command to input status commands															
1	%	1	I	N	P	T	=	1	*2	(CR)		RGB selected			
2	%	1	I	N	P	T	=	2	*2	(CR)		VIDEO selected			
3	%	1	I	N	P	T	=	3	*2	(CR)		DIGITAL selected			
4	%	1	I	N	P	T	=	4	*2	(CR)		STORAGE selected			
5	%	1	I	N	P	T	=	5	*2	(CR)		NETWORK selected			
Get mute settings															
1	%	1	A	V	M	T	=	3	0	(CR)		Video+audio Mute OFF			
2	%	1	A	V	M	T	=	1	1	(CR)		Video Mute ON			
3	%	1	A	V	M	T	=	2	1	(CR)		Audio Mute ON			
4	%	1	A	V	M	T	=	3	1	(CR)		Video+audio mute ON			
Get error status															
1	%	1	E	R	S	T	=	*3	*4	*5	*6	*7	*8	(CR)	
Get time and status of lamp															
1	%	1	L	A	M	P	=	*9	(SP)	*10	(CR)				
Get list of input switching															
1	%	1	I	N	S	T	=	*11	(CR)						
Get projector name															
1	%	1	N	A	M	E	=	*12	(CR)						
Get manufacturer name															
1	%	1	I	N	F	1	=	*13	(CR)						
Get product name															
1	%	1	I	N	F	2	=	*13	(CR)						
Get other information (optional)															
1	%	1	I	N	F	O	=	*13	(CR)						

*2: Input number, which is any of “1” to “9”, but types and the numbers of selectable input connectors differ depending on connected projectors.

*3: Fan error

*4: Lamp error

- *5: Temperature error
- *6: Cover open error
- *7: Filter error
 - 0: No error/No error detection function, 1: Warning, 2:Error
- *8: Other errors
- *9: Accumulated time of lamp, which is any of 0 to 99999.
(For projectors that do not count the accumulated time, the value is 0 at all times.)
- *10: Whether the lamp illuminates or not (0 or 1). 0: Not illuminate, 1: Illuminates
For devices containing multiple lamps, the accumulated time and status separated with a (SP) are sent.
- *11: Source number, which is input switchable. Any of 11 to 59 (Meaning is the same as that of "%INPT" command). For devices containing several inputs, several statuses separated with a (SP) are sent.
- *12: Up to 64 characters, 20 to FF in hex.
- *13: Up to 32 characters, 20 to 7F in hex.

9.6.5 RELOAD button

Reloads the displayed WEB menu and displays it on the WEB browser.
Click the "RELOAD" button.

9.6.6 BACK button

Returns to the COMMAND EDIT menu (control command list).
Click the "BACK" button.

9.6.7 SEND button

Applies settings of COMMAND EDIT menu to the SWC-2000.
Click the "SEND" button.

9.7 REPLY COMMAND menu (Reply command list)

You can display the REPLY COMMAND menu (Reply command list) by entering “http://(SWC-2000’s IP address)/replycommand.html” into the address bar.

Up to 32 reply commands can be registered

Click the command number button you want to edit to jump to the COMMAND EDIT menu. Select the reply command number you want to edit.

REPLY COMMAND

NAME EDIT DATA MONITOR COMMAND EDIT **REPLY COMMAND** COMMAND LINK COMMAND EXECUTION LED LAN/COM BACKUP OTHERS

<REPLY COMMAND LIST>

CMD	MEMO	CMD	MEMO	CMD	MEMO	CMD	MEMO
CMD1	CH1 REPLY	CMD2		CMD3		CMD4	
CMD5		CMD6		CMD7		CMD8	
CMD9		CMD10		CMD11		CMD12	
CMD13		CMD14		CMD15		CMD16	
CMD17		CMD18		CMD19		CMD20	
CMD21		CMD22		CMD23		CMD24	
CMD25		CMD26		CMD27		CMD28	
CMD29		CMD30		CMD31	OK	CMD32	NG

<REPLY COMMAND COPY/DELETE>

COPY: CMD1 ▼ TO: CMD1 ▼ COPY

DELETE: CMD1 ▼ DELETE

RELOAD

[Fig. 9.18] Reply command edit page

- ① WEB menu link
- ② REPLY COMMAND LIST
- ③ REPLY COMMAND COPY/DELETE
- ④ Reload button

9.7.1 WEB menu links

Jump to the clicked WEB menu.
Click the desired link.

9.7.2 REPLY COMMAND LIST

Displays MEMOs (notes) that includes reply command CMD and reply command name of reply commands 1 to 32. You can set MEMOs in “9.8 REPLY COMMAND menu (Advanced setting of reply command)”.
Click the desired CMD button to display the detailed setting page.

Prerequisite N/A

Settable range “CMD” button: CMD 1 to CMD 32

9.7.3 REPLY COMMAND COPY/DELETE

Copies and deletes registered reply commands.

For copying : Select the desired CMD numbers and click the “COPY” button.

For deleting : Select the desired CMD number and click the “DELETE” button.

Example: COPY

A reply command registered in CMD1 will be copied to CMD10 when the “COPY” button is clicked.



[Fig. 9.19] Copy setting

Example: DELETE

A reply command registered in CMD1 will be deleted when the “DELETE” button is clicked.



[Fig. 9.20] Delete setting

9.7.4 Reload button

Reloads the displayed WEB menu and displays it on the WEB browser.

Click the “RELOAD” button.

9.8 REPLY COMMAND menu (Advanced setting of reply command)

You can display the following page by clicking the “CMD” button on REPLY COMMAND menu (Reply command list)

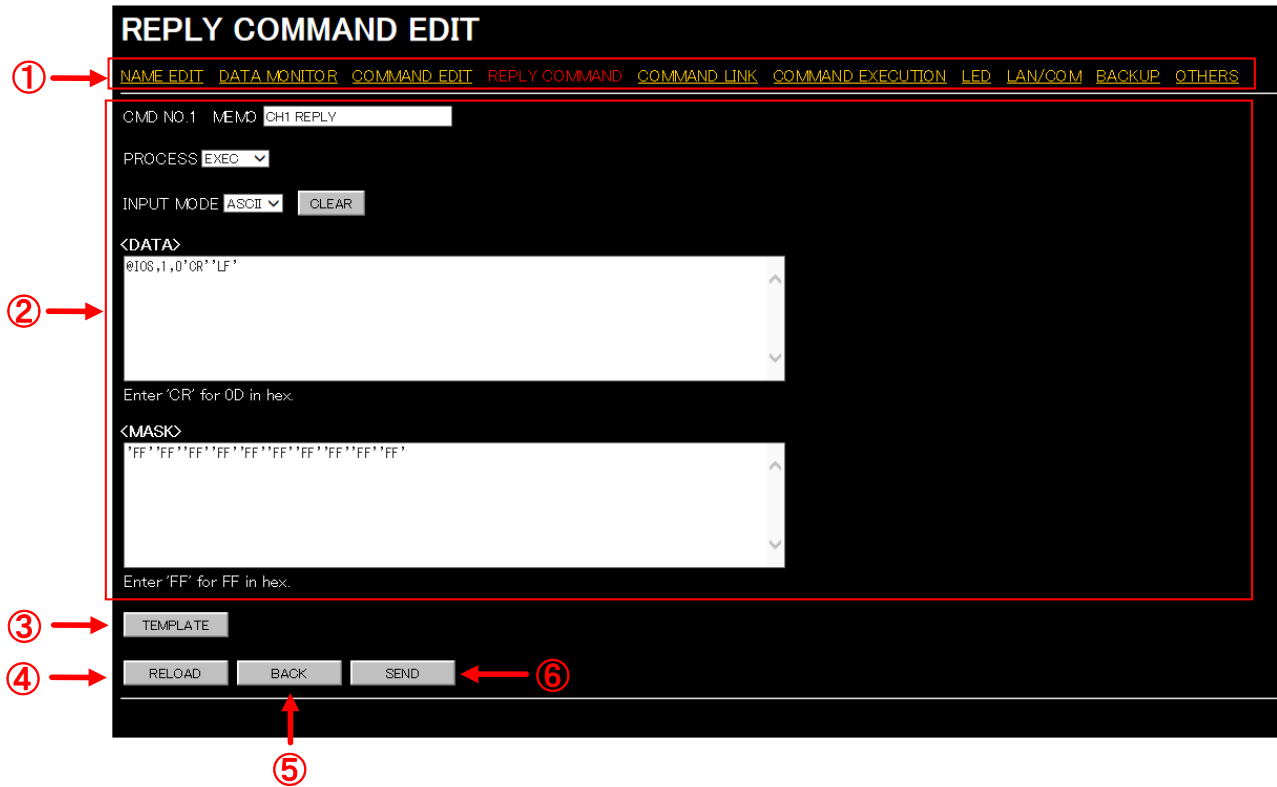

[Fig. 9.21] REPLY COMMAND menu (Advanced setting of reply command)

- ① WEB menu link
- ② Setting reply command
- ③ TEMPLATE button
- ④ RELOAD button
- ⑤ BACK button
- ⑥ SEND button

9.8.1 WEB menu links

Jump to the clicked WEB menu.

Click the desired link.

9.8.2 Setting reply command

You can set reply commands by setting the following items.

[Table 9.8] Setting items of reply command

Item	Description	Setting value
MEMO	Register up to 14 characters as a note. The registered note is displayed on the reply command list.	20 to 7D in ASCII codes except for 2C (.) "20" [Default] 20
PROCESS	Select "STOP" (to stop the next operation), "EXEC" (to execute it), or "RETRY" (to send the command again) for when received data and reply command data match.	STOP EXEC [Default] RETRY: Resend commands
INPUT MODE (Input mode of reply command data)	Set the input mode of reply command data. Select "ASCII" if "DATA" of "COMMAND" consists of only 0A, 0D, and 20 to 7D of ASCII codes. Select "HEX" if "DATA" of "COMMAND" includes other codes.	ASCII [Default] HEX
SIZE	Set the number of bytes to be received starting with the first byte. Selectable only if "INPUT MODE" is set to "HEX".	"0" to "30" "0" [Default]
DATA (Reply command data)	Set the command from the first byte according to the number of bytes set in "SIZE" (up to 30 bytes, case sensitive).	0A, 0D, 20 to 7D in ASCII, 00 to FF in hex [Default]: 20 (space)
MASK	The binary AND operation is executed for the received data and MASK data. The result data is compared with the reply command data. (Use this item to determine the state using the received data bit. Settable if "COMMAND INPUT MODE" is set to "HEX"; if "ASCII" is selected, "FF" is set automatically.)	00 to FF (Hex) [Default]: All: "FF"

Those default values do not apply to reply commands 31 and 32

Click the "CLEAR" button to restore the default value of SIZE, DATA and MASK.

■ Loop back function

If the SWC-2000 sends a communication command back to the SWC-2000 itself using the loop back function, it replies “OK” if processed normally while it replies “NG” if parameter or command is incorrect. (This differs from reply commands to communication commands received externally; not loop back.) Since “OK” and “NG” are registered to reply commands 31 and 32 by factory default, respectively, do not edit or delete those commands if you use the loop back function and check reply commands.

[Table 9.9] Default of reply command

Number	SIZE	PROCESS	DATA	MASK	MEMO
1	0 byte	EXEC	All: 00	All: FF	All: 20 (space)
2	0 byte	EXEC	All: 00	All: FF	All: 20 (space)
:	:	:	:	:	:
30	0 byte	EXEC	All: 00	All: FF	All: 20 (space)
31	2 bytes	EXEC	OK	All: FF	OK
32	2 bytes	STOP	NG	All: FF	NG

【See: 9.6.2 Setting control command】

■ **Mask data**

The binary AND operation is executed for the received data and MASK data. The result data is compared with the reply command data. You can set the AND operation if you want to check the status by bits of the received data.

[If ASCII codes (text) are replied from an external device]

Since the received data and “Reply command data” are compared without any changes, set “MASK” to “FF”. (If you set “COMMAND INPUT MODE” of reply command to “ASCII”, it is automatically set to “FF”.)

For example, if “0” of ASCII codes (“30” in hex) is replied:

	Binary		Binary	Hexadecimal
(Received data)	00110000	& (MASK)	11111111	=30
(Reply command data)	00110000			=30 matched

[If status is determined using bits of the received data]

Set only bits that determine the Mask data to “1” and set other bits to “0”.

For example, if determining status using the second bit from the left:

	Binary		Binary	Hexadecimal
(Received data)	11111111	& (MASK)	01000000	=40
(Reply command data)	01000000			=40 matched

	Binary		Binary	Hexadecimal
(Received data)	10111111	& (MASK)	01000000	=00
(Reply command data)	01000000			=40 not matched

9.8.3 TEMPLATE button

Registers reply commands only by selecting the desired command from list.

You can open the template for reply command by clicking the “TEMPLATE” button.

IDK’s reply commands and PJLink commands are originally registered. You can register other commands directly.

You can display buttons for inputting ASCII codes by selecting “ASCII” from the “MODE” in order to prevent incorrect input. (These buttons are displayed only if you set “INPUT MODE” to “HEX”.)

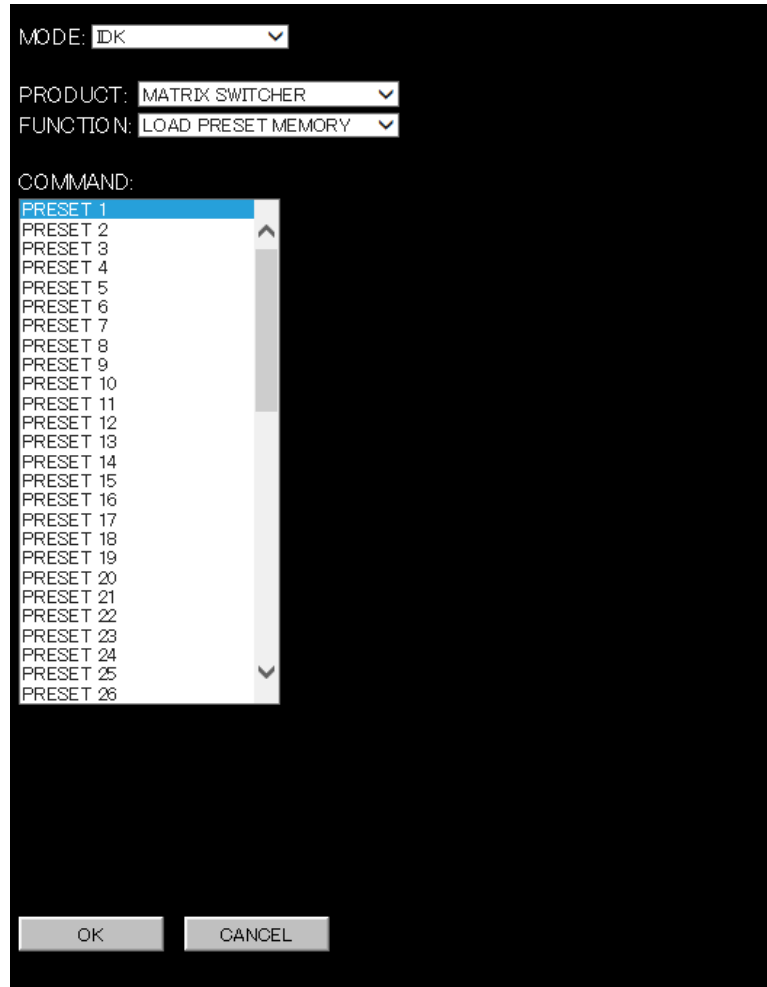

[Fig. 9.22] Input support for reply command

The mode is switched automatically in accordance with the product.

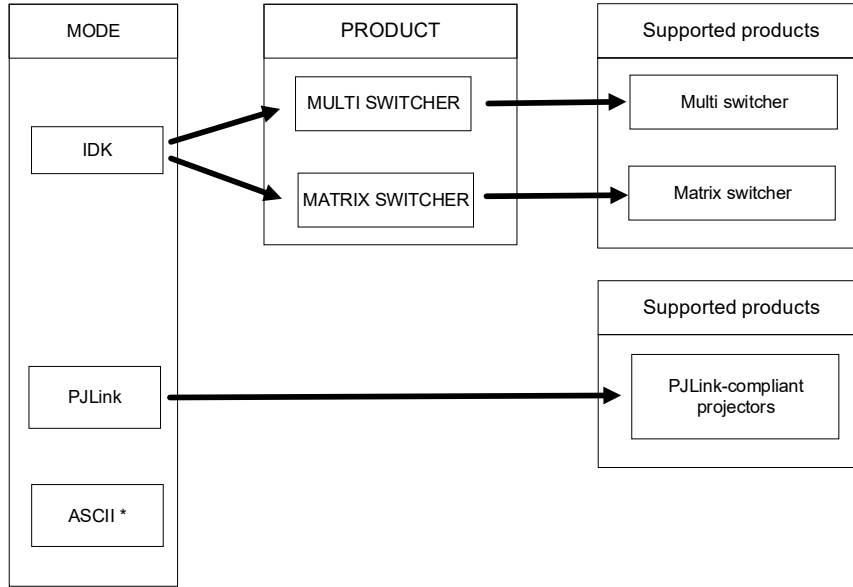

[Fig. 9.23] Supported products

[Table 9.10] MODE

MODE	Description
IDK	Displays reply command's templates for matrix switchers and multiple switchers.
PJLink	Displays PJLink command's template.
ASCII*	Displays buttons for inputting ASCII codes. For all products

* Displayed only if you set "INPUT MODE" to "HEX".

If you set "INPUT MODE" to "ASCII", the following input box is displayed.



[Fig. 9.24] Control command input box for ASCII

Use the following values if you set "INPUTMODE" to "ASCII" and enter special characters.

[Table 9.11] Values for special characters

HEX	ASCII	HEX	ASCII
"00"	'NUL'	"11"	'DC1'
"01"	'SOH'	"12"	'DC2'
"02"	'STX'	"13"	'DC3'
"03"	'ETX'	"14"	'DC4'
"04"	'EOT'	"15"	'NAK'
"05"	'ENQ'	"16"	'SYN'
"06"	'ACK'	"17"	'ETB'
"07"	'BEL'	"18"	'18'
"08"	'BS'	"19"	'EM'
"09"	'HT'	"1A"	'SUB'
"0A"	'LF'	"1B"	'ESC'
"0B"	'VT'	"1C"	'FS'
"0C"	'0C'	"1D"	'GS'
"0D"	'CR'	"1E"	'RS'
"0E"	'S0'	"1F"	'US'
"0F"	'SI'	"7F"	'DEL'
"10"	'DLE'		

If you set "INPUT MODE" to "HEX", the following input boxes for reply command data and mask data are displayed.

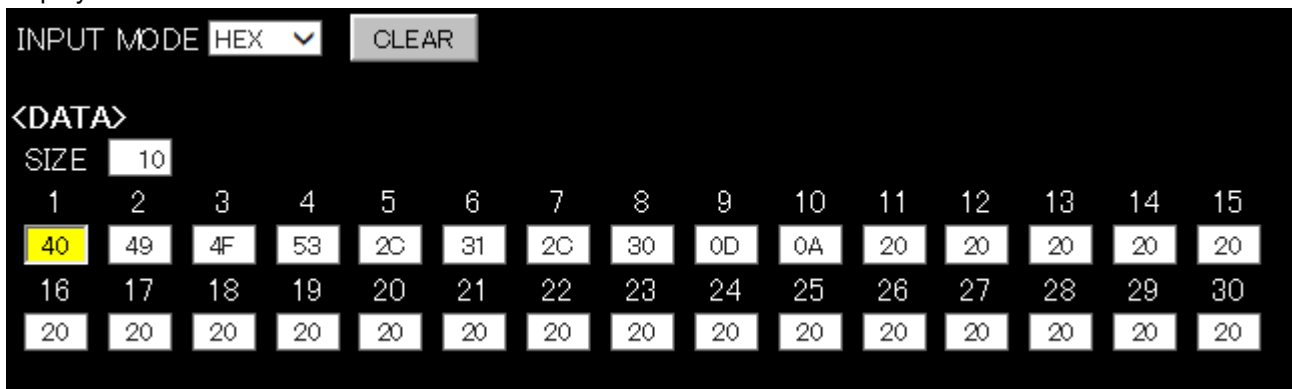

[Fig. 9.25] Reply command input boxes for HEX

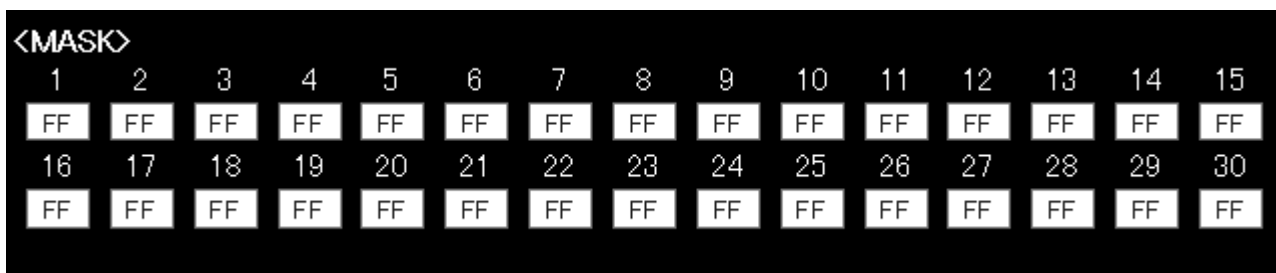

[Fig. 9.26] Mask data input boxes for HEX

If you set “MODE” to “IDK”, the “PRODUCT” list is displayed.

1. Select the desired “PRODUCT” to display reply commands for each product on the “COMMAND” list.

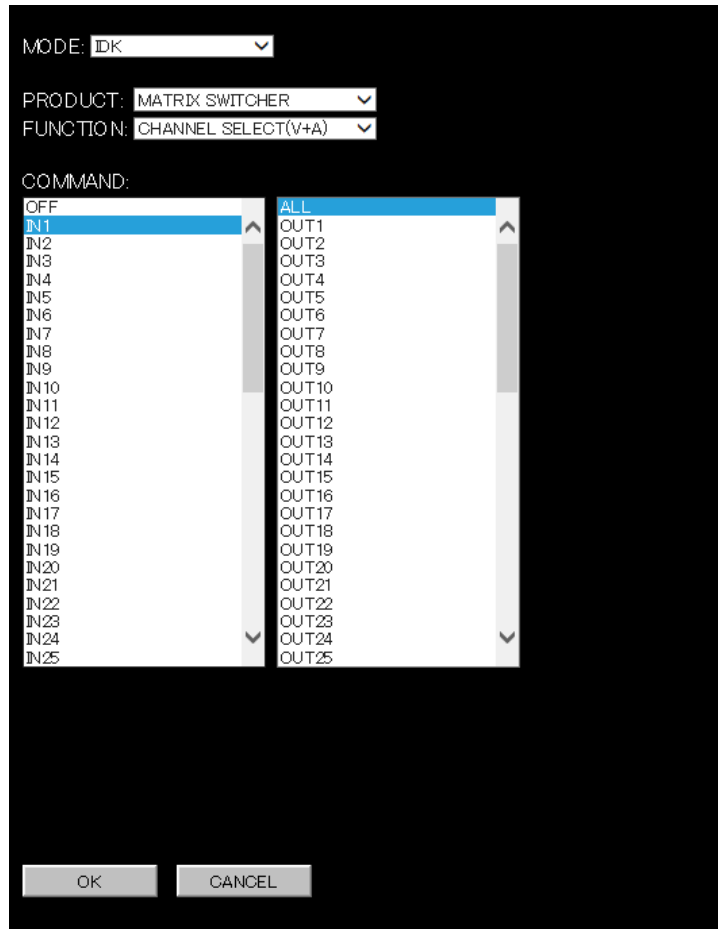

[Fig. 9.27] CHANNEL SELECT (V+A) template

2. Select the desired control command and click the “OK” button to apply it to “9.7 REPLY COMMAND menu (Reply command list)”.
3. The control command is entered on the field below mentioned in red.
4. Since you can set the “DATA” and “MASK” items from this template, you need to edit “MEMO” and “PROCESS” as needed.

5. When you finish setting, click the “SEND” button.

[Fig. 9.28] Reply command has been input using input support

9.8.4 RELOAD button

Reloads the displayed WEB menu and displays it on the WEB browser.
Click the “RELOAD” button.

9.8.5 BACK button

Returns to the REPLYCOMMAND menu (Reply command list).
Click the “BACK” button.

9.8.6 SEND button

Applies settings of REPLYCOMMAND menu (Advanced setting of reply command) to the SWC-2000.
Click the “SEND” button.

9.9 COMMAND LINK menu (Selecting button)

You can display the COMMAND LINK menu by entering “http://(SWC-2000’s IP address)/ commandlink.html” into the address bar.

This menu is for selecting the button to which registered control command is linked.



[Fig. 9.29] COMMAND LINK

- ① WEB menu
- ② STANDBY BUTTON
- ③ INVALID TIME
- ④ RELOAD

9.9.1 WEB menu links

Jump to the clicked WEB menu.
Click the desired link.

9.9.2 STANDBY BUTTON

Edits linking between Standby buttons and control command buttons.

[Table 9.12] Link edit button

POWER		BUTTON
POWER ON	POWER OFF	Control command buttons1 to 16

【See: 7.7 Executing control command】

9.9.3 COMAND LINK COPY/DELETE

Copies and deletes linking.

For copying : Select the desired CMD numbers and click the “COPY” button.

For deleting : Select the desired CMD number and click the “DELETE” button.

Example: COPY

Control commands linked to POWER ON will be copied to Control command button1 when the “COPY” button is clicked.



[Fig. 9.30] Copy

Example: DELETE

Control commands linked to POWER ON will be deleted when the “DELETE” button is clicked.



[Fig. 9.31] Delete

9.9.4 INVALID TIME

Sets the waiting time from starting control command execution to receiving the next command. Use this menu to prevent repeated execution caused by pressing the control command execution key twice.

Enter the desired number of milliseconds (0 to 999999) into the "INVALID TIME" field.

- 0ms to 999999ms

- [Default]: 0 ms



[Fig. 9.32] INVALID TIME

The longer time either of control command execution time or the time set in this menu will be applied as the invalid operation time. Only operations from ports that execute control commands will be invalid; operations from other ports can be performed. For example, if you execute a control command from the front panel, you cannot perform all operations from the front panel until the control command execution time or time set in this menu passes.

9.9.5 RELOAD button

Reloads the displayed WEB menu and displays it on the WEB browser.

Click the "RELOAD" button.

9.10 COMMAND LINK menu

Links control commands to each execution condition.



[Fig. 9.33] COMMAND LINK menu (Linking)

- ① WEB menu
- ② TOGGLE and COMMAND (Linking control command)
- ③ RELOAD
- ④ BACK button
- ⑤ SEND button

9.10.1 WEB menu links

Jump to the clicked WEB menu.
Click the desired link.

9.10.2 TOGGLE and COMMAND (Linking control command)

Links up to 10 commands to an execution condition of control command.

If multiple commands are linked, commands are executed in order of registration. If the same command is linked for several times, it is repeatedly executed.

When you finish setting, click the "SET" button.

Setting values:

- OFF [Default]
- Control command1 to 32

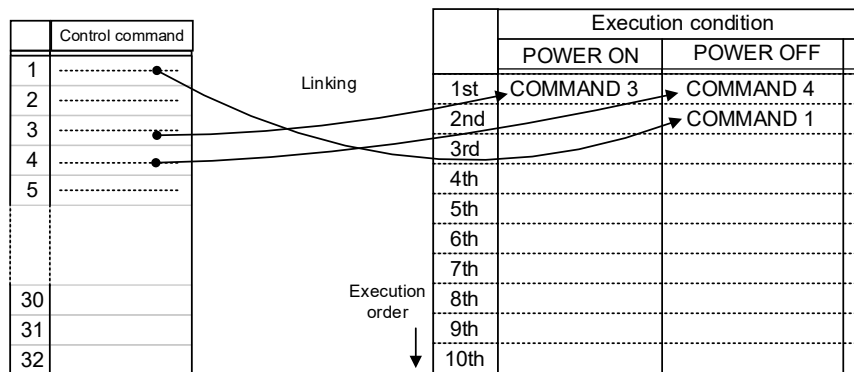

[Fig. 9.34] Linking control command

* Functions can be executed also from "9.2 MAIN menu" and control commands. (Power ON/OFF is not executed if power is supplied from the AC adapter.)

Select a control command that is registered in "9.6.2 Setting control command". If you do not want to execute, select "OFF".

Tick "TOGGLE" to execute PLANE-A and PLANE-B commands alternately and select "AUTO", "PLANE A", or "PLANE B" for "STARTUP STATUS". If you select "AUTO", the condition at the time of power OFF will be maintained.

[Default] All "TOGGLE": Unticked (disabled)

9.10.3 RELOAD button

Reloads the displayed WEB menu and displays it on the WEB browser.
Click the "RELOAD" button.

9.10.4 BACK button

Returns to the COMMAND LINK menu (Selecting button).
Click the "BACK" button.

9.10.5 SEND button

Applies settings of COMMAND LINK menu to the SWC-2000.
Click the "SEND" button.

9.11 COMMAND EXECUTION menu

You can display the COMMAND EXECUTION menu by entering “http://(SWC-2000’s IP address)/commandexecution.html” into the address bar.

This menu is for executing a control command that is registered to the SWC-2000 if the SWC-2000 is powered on.

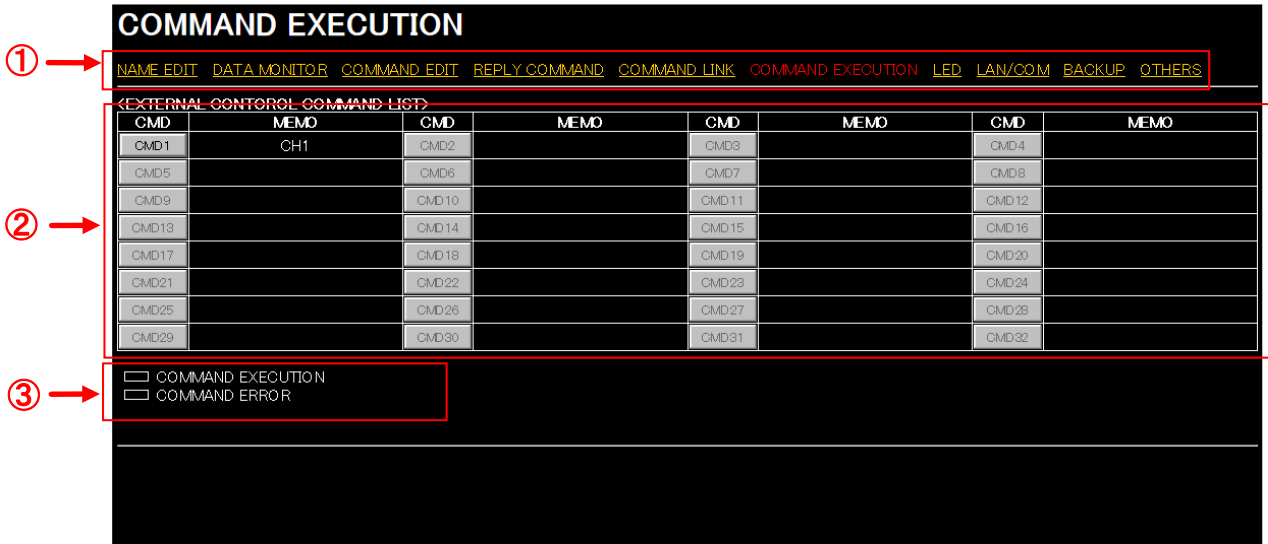

[Fig. 9.35] COMMAND EXECUTION menu

- ① WEB menu link
- ② EXTERNAL CONTROL COMMAND LIST...
- ③ COMMAND EXECUTION/COMMAND ERROR

9.11.1 WEB menu links

Jump to the clicked WEB menu.
Click the desired link.

9.11.2 EXTERNAL CONTROL COMMAND LIST

Executes a registered control command
Click the desired control command button.

9.11.3 COMMAND EXECUTION/COMMAND ERROR indicator

Shows the current control status.

COMMAND EXECUTION:

Black : The SWC-2000 does not execute a control command of external devices.

Orange : The SWC-2000 executes a control command of external devices.

COMMAND ERROR:

Black : No error occurs.

Orange : Timeout between the SWC-2000 and controlled device occurs or an error of IDK or PJLink products is replied.

【See: 7.6 Control status LED】

9.12 LED menu

You can display the LED menu by entering “http://(SWC-2000’s IP address)/ led.html” into the address bar. This menu is for setting LED’s lighting and its conditions.

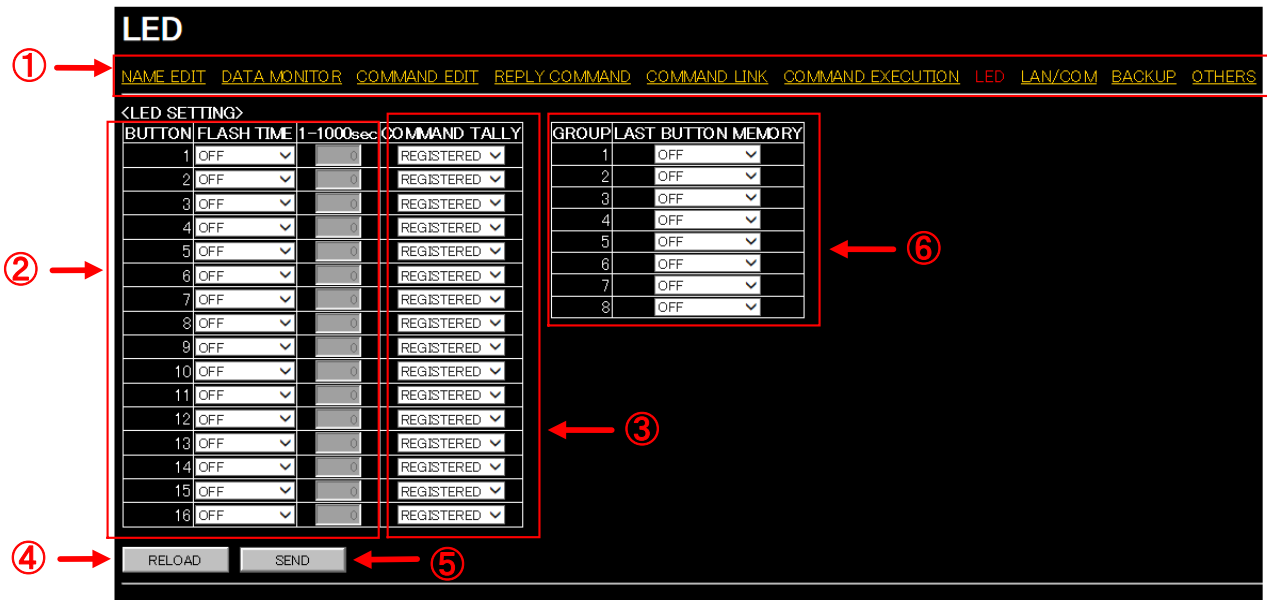

[Fig. 9.36] LED menu

- ① WEB menu link
- ② Blinking pattern
- ③ Lighting condition
- ④ RELOAD
- ⑤ SEND button
- ⑥ LAST BUTTON MEMORY (Start-up lighting by group)

9.12.1 WEB menu links

Jump to the clicked WEB menu.
Click the desired link.

9.12.2 Blinking pattern

Sets the LED's blinking pattern of control command button.

If the execution is not complete even after the specified time passes, the LED continues to blink until the execution is complete.

If you specify the desired "TIME", the LED continues to blink until the specified time comes.

When you finish setting, click the "SEND" button.

"FLASH TIME":

- EXECUTION: Blinks while control commands are being executed [Default]
- OFF: Does not

"1-1000sec": Continues to blink until the specified time (1 to 1000 seconds) comes.

9.12.3 Lighting condition

Sets when and which control command buttons will light.

Select one of the following options for "COMMAND TALLY".

- REGISTERED: Lights when a control command is registered.
- EXECUTION: Lights while a control command is being executed.
- GROUP1 to 8: Control command buttons are divided into up to eight groups and the last clicked buttons of each group will light.
 - Lights only if the control command is linked to the control command button and the button is pressed.
 - Lights regardless of the execution result.
 - If another button in the same group lights, the button keeps lighting.

When you finish setting, click the "SEND" button.

Example: Control commands are linked to control command buttons 1, 2, 7 to 10, and 13 to 18.

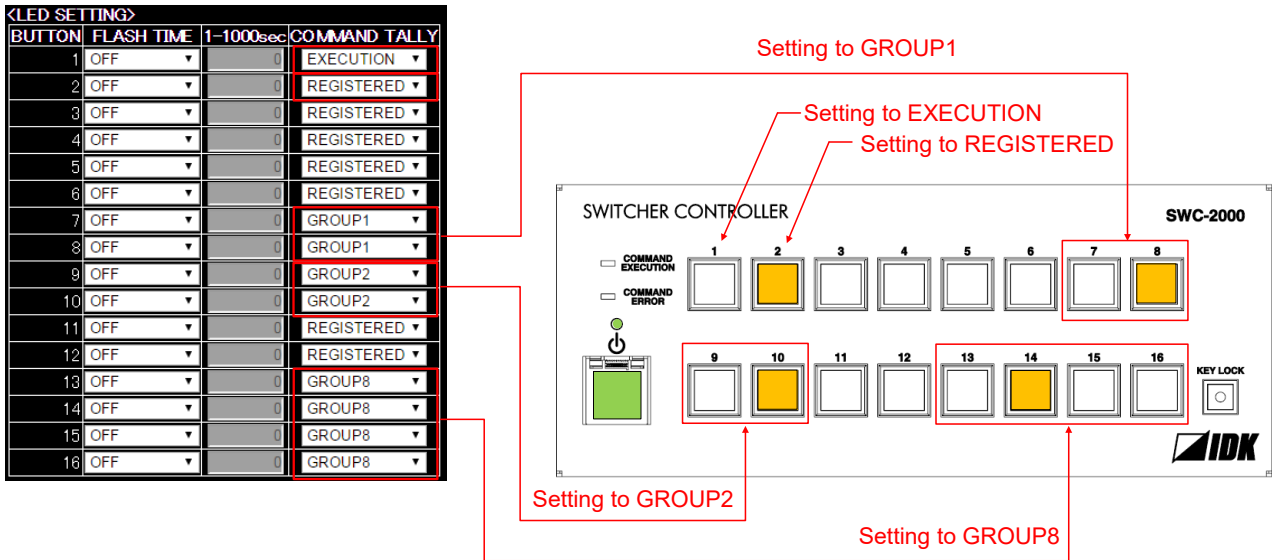

[Fig. 9.37] Grouping control command buttons

Setting for Each control command button

Each control command button has PLANE A and PLANE B. If you register commands for the both sides, they are executed alternately every time pressing the button.

[Table 9.13] Toggle operation for control command button

COMMAND TALLY	You register a command only for one PLANE.	You register a command for both PLANEs.
REGISTERED	Lights if a control command is registered.	Lights if PLANE A will be executed at the next press; blinks if PLANE B will be executed at the next press.
EXECUTION	Lights while a control command is being executed.	Lights if PLANE A will be executed at the next press; does not light if PLANE B will be executed at the next press.

If execution time is 500 ms. or shorter, it lights for only 500 ms.

9.12.4 RELOAD button

Reloads the displayed WEB menu and displays it on the WEB browser.
Click the "RELOAD" button.

9.12.5 SEND button

Applies settings of LED menu to the SWC-2000.
Click the "SEND" button.

9.12.6 LAST BUTTON MEMORY (Start-up lighting by group)

Sets start-up lighting for control command buttons which are grouped in "9.12.3 Lighting condition".
Select "ON" or "OFF" for "LAST BUTTON MEMORY".

- ON : The last lighting status will be maintained.
- OFF : Does not light. [Default]

9.13 LAN / COM menu

You can display the LAN/COM menu by entering “http://(SWC-2000’s IP address)/lancom.html” into the address bar.

This menu is for setting LAN and RS-232C communication to connect the SWC-2000 and external devices.

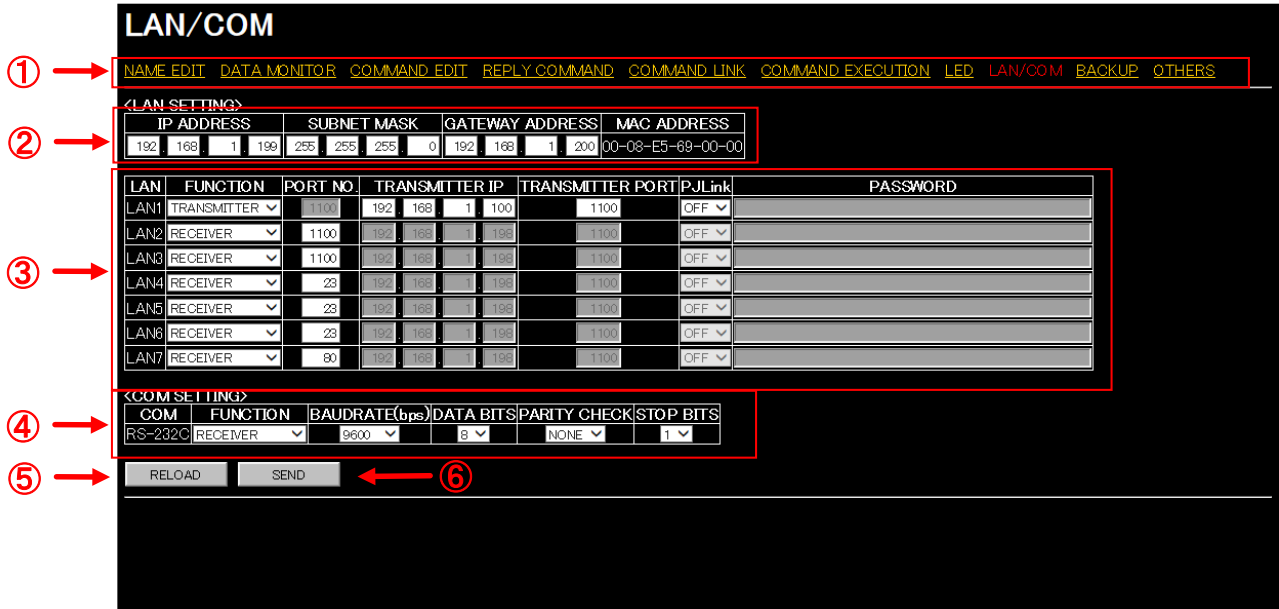

[Fig. 9.38] LAN / COM menu

- ① WEB menu
- ② LAN SETTING
- ③ Operation mode of LAN communication
- ④ COM SETTING
- ⑤ RELOAD
- ⑥ SEND button

9.13.1 WEB menu links

Jump to the clicked WEB menu.

Click the desired link.

9.13.2 LAN SETTING

Sets IP address, subnet mask, and gateway address to control the SWC-2000 externally.

The SWC-2000's MAC address is also displayed, but it cannot be set.

When you finish setting, click the "SEND" button.

[Table 9.14] Setting address

Item	Settable values	Default
IP address	0.0.0.0 to 255.255.255.255	192.168.1.199
Subnet mask	0.0.0.0 to 255.255.255.255	255.255.255.0
Gateway address	0.0.0.0 to 255.255.255.255	192.168.1.200

9.13.3 Operation mode of LAN communication

Sets the operation mode of LAN communication.

Select "RECEIVER" or "TRANSMITTER" for "FUNCTION".

- "RECEIVER" : The SWC-2000 is controlled externally.
- "TRANSMITTER" : The SWC-2000 controls external devices. Set the information of external device as shown below.

Connection is divided into the two purpose depending on the set port number: for communication commands and for WEB browser control.

When you finish setting, click the "SEND" button.

[Table 9.15] LAN communication setting

Setting item	Operation mode	
	RECEIVER	TRANSMITTER
[FUNCTION] Operation mode	RECEIVER [Default]	TRANSMITTER
[TRANSMITTER IP] Destination IP address	N/A	0.0.0.0 to 255.255.255.255 [Default] 192.168.1.199
[PJLink] PJLink protocol connection	N/A	ON: Use OFF: Not use [Default]
[TRANSMITTER PORT] Destination port number*1	N/A	1 to 65535 [Default] 1100
[PASSWORD] PJLink protocol's password*2	N/A	ASCII codes 20,30 to 39, 41 to 5A, 61 to 7A in hex [Default] 20 (space)

*1: If "PJLink" is set to "ON", the port number is "4352" fixed.

*2: UP to 32 characters. You do not need to set a password if you do not want to use password authentication.

[Table 9.16] TCP port number

Port	Setting value
Communication port for control commands	23,1100,6000 to 6999
Communication port for WEB browser	80,5000 to 5999

[Default] Connections1 to 3: 1100, Connections4 to 6: 23, Connection7: 80

Tip:

The SWC-2000 has a communication port only for WEB browser. You do not need to set connection if using only one PC.

9.13.4 COM SETTING

Set the RS-232C communication.

Select "RECEIVER" or "TRANSMITTER" for "FUNCTION".

- "RECEIVER" : The SWC-2000 is controlled externally.
- "TRANSMITTER": The SWC-2000 controls external devices. Set the information of external device as shown below.

When you finish setting, click the "SEND" button.

[Table 9.17] RS-232C communication setting

Setting item	Setting value	Default
[FUNCTION] Operation mode	RECEIVER, TRANSMITTER	RECEIVER
[BAUDRATE(bps)]	4800, 9600, 19200, 38400	9600
[DATA BITS] (bit)	8, 7	8
[PARITY CHECK]	NONE, EVEN, ODD	NONE
[STOP BITS] (bit)	1, 2	1

9.13.5 RELOAD button

Reloads the displayed WEB menu and displays it on the WEB browser.

Click the "RELOAD" button.

9.13.6 SEND button

Applies settings of LAN / COM menu.

Click the "SEND" button.

9.14 BACKUP / RESTORE menu

You can display the BACKUP / RESTORE menu by entering "http://(SWC-2000's IP address)/backup.html" into the address bar.

This menu is for backing up the SWC-2000's settings on the PC as a file that can be applied to other SWC-2000s.

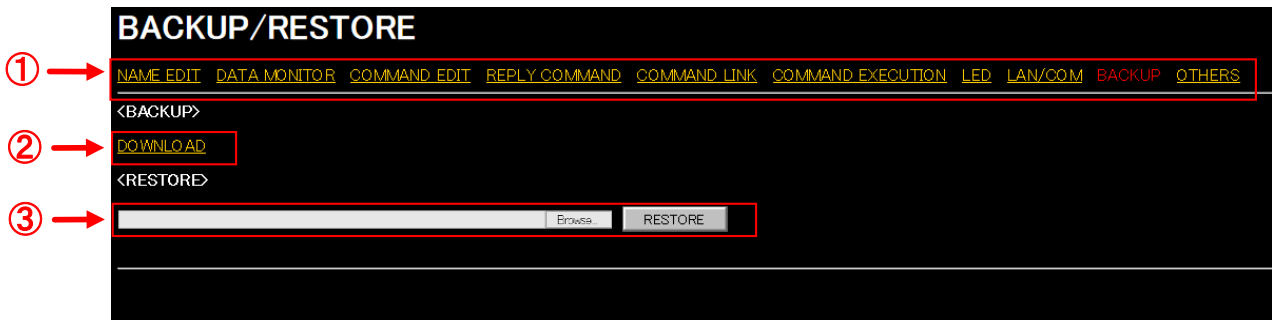

[Fig. 9.39] BACKUP / RESTORE menu

- ① WEB menu links
- ② BACKUP
- ③ RESTORE

9.14.1 WEB menu links

Jump to the clicked WEB menu.
Click the desired link.

9.14.2 BACKUP

Downloads and save the settings saved in the SWC-2000.
Click the “DOWNLOAD” link to save the downloaded data on a PC as a backup file.

9.14.3 RESTORE

Applies saved setting data to the SWC-2000.

Click the “Browse...” button to select the backed up file and then click the “RESTORE” button to overwrite all settings.

9.15 OTHERS

You can display the OTHERS menu by entering “http://(SWC-2000’s IP address)/ others.html” into the address bar.

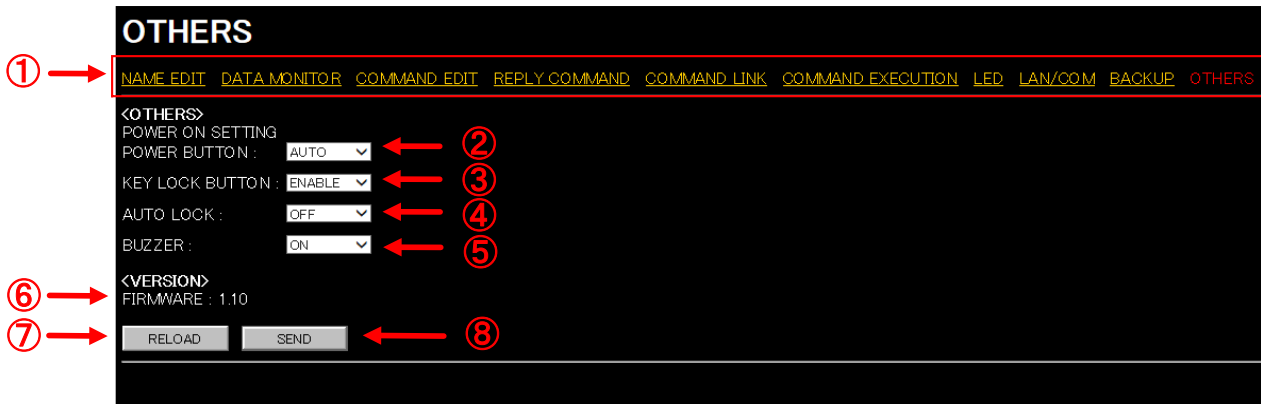

[Fig. 9.40] OTHERS menu

- ① WEB menu
- ② POWER ON SETTING STANDBY BUTTON
- ③ KEY LOCK BUTTON
- ④ AUTO LOCK
- ⑤ BUZZER
- ⑥ VERSION
- ⑦ RELOAD
- ⑧ SEND button

9.15.1 WEB menu links

Jump to the clicked WEB menu.
Click the desired link.

9.15.2 POWER ON SETTING STANDBY BUTTON

Sets the start-up status for when power is supplied from the AC adapter.

- AUTO: The last status is kept. [Default]
- OFF : Power off (standby)
- ON : Power on (the SWC-2000 is powered on completely)

[Table 9.18] Start-up status setting

Default setting of Standby button	Start-up status last time AC adapter is disconnected	Start-up status when power is supplied from AC adapter
AUTO	OFF	OFF
	ON	ON
OFF		OFF
ON		ON

9.15.3 KEY LOCK BUTTON

Enables/disables the KEYLOCK button.

If you select "DISABLE", the automatic lock of control command buttons ("9.15.4 AUTO LOCK") will be "OFF" automatically.

- ENABLE : Enables the KEYLOCK button. [Default]
- DISABLE : Disable the KEYLOCK button.

9.15.4 AUTO LOCK

Enables/disables the automatic lock.

- ON : When no operation is performed for 30 seconds, control command buttons will be locked automatically.
Enable the keylock button ("9.15.3 KEY LOCK BUTTON") in order to enable this function.
- OFF: Disable the automatic lock. [Default]

9.15.5 BUZZER

Enables/disables the buzzer sound for when control command buttons or the KEYLOCK button are pressed.

- ON : Enables the buzzer sound. [Default]
- OFF: Disables the buzzer sound.

9.15.6 VERSION

Displays the firmware version.

9.15.7 RELOAD button

Reloads the displayed WEB menu and displays it on the WEB browser.
Click the "RELOAD" button.

9.15.8 SEND button

Applies settings of OTHERS.
Click the "SEND" button is clicked.

10 Product specification

Item		Description
Number of control command buttons		16 buttons
Number of control commands that can be linked		Up to 10 commands per button
Number of control commands that can be registered		Up to 32 commands
Control	RS-232C	1 port/male D-sub (9-pin)
	LAN	1 port/RJ-45 10Base-T/100Base-TX (Auto Negotiation), Auto MDI/MDI-X
Recommended products		IDK's MSD/FDX series PjLink supported products, and others (General purpose products)
General	Power	DC 5 V 0.6 A
	Power consumption	About 3 W
	Dimensions	8.5 (W) × 3.5 (H) × 1.6 (D)" (215 (W) × 88 (H) × 40.6 (D) mm) (Excluding connectors and the like) (*1)
	Weight	1.8 lbs. (0.8 kg)
	Temperature	Operating : 32°F to 104°F (0°C to +40°C) Storage : -4°F to +176°F (-20°C to +80°C)
	Humidity	Operating/Storage: 20% to 90% (Non Condensing)

*1 When mounting the SWC-2000 to an EIA rack, use the optional rack mounting brackets. By using the mounting kit, one or two SWC-2000s can be mounted to the 2U-EIA rack.

■ Recommended products

Items		Parts number
IDK's products	MSD series	MSD-701AMP, MSD-6203, MSD-6204, MSD-6206, MSD-6208, MSD-701UHD, MSD-702UHD, MSD-801UHD, MSD-802UHD, MSD-7201UHD, MSD-7202UHD, MSD-7203UHD, MSD-7204UHD, MSD-7201UHDTB, MSD-7202UHDTB, MSD-7203UHDTB, MSD-7204UHDTB, MSD-402, MSD-501, MSD-502, MSD-701, MSD-702, MSD-EX32
	FDX-S series	FDX-S16U, FDX-S32U, FDX-S16, FDX-S32
	FDX series	FDX-12UHD, FDX-32UHD, FDX-08, FDX-16, FDX-32, FDX-64
Other products		PjLink supported products, and others (General purpose products)

11 Troubleshooting

This chapter recommends what to do if you have problems operating the SWC-2000.

In case the SWC-2000 does not work correctly, please check the following items first.

- Are the SWC-2000 and all devices plugged in and powered on normally?
- Are cables connected correctly?
- Are there no loose connections?
- Are appropriate cables supported by devices being used?
- Are specifications of connected devices matched to each other?
- Are settings of the sink device correct?
- Are there any close objects that may cause noise?

If the problem still cannot be solved, perform the following actions. Refer to manuals of connected devices as well, since they may possibly be the cause of the problem.

Problem	Cause/Check item/Solution	Page
• Button operation		
Buttons do not operate.	Ensure that keys are not locked.	26
	Since no control command is registered by factory default, control command buttons do not work. Register and link control commands in order to enable these keys.	43, 70, 82
	When a control command is executed using a control command button or external device, all buttons are disabled until the command is executed or "INVALID TIME" passes.	72
	Control command buttons can be set to be disabled for a desired time. Check the setting.	26
	Immediately after start-up, all buttons are disabled until the connection of the sink device is confirmed.	23
• Control command		
Control command control from the PC to the SWC-2000 cannot be executed.	Are the following items set correctly? For RS-232C: baud rate and data length For LAN: IP address and subnet mask	83
	Is the operation mode of the communication port set to "RECIEVER" mode? If it is set to "TRANSMITTER" mode, the communication command of the SWC-2000 cannot be executed externally.	84
"@ERR,6" is returned.	If control commands are executed by communication commands, control command communication are disabled until the control commands are executed or "INVALID TIME" passes.	72
	Immediately after start-up, the communication command control function is disabled until the connection of the external device is confirmed.	23

Problem	Cause/Check item/Solution	Page
● Sending control command function		
Control command is not sent.	Ensure that the registered control command and the number of bytes are correct. Devices requiring delimiters may not execute commands if the delimiters are not sent. If the set number of bytes is not correct, the control command is not sent completely or unnecessary data is sent after the control command.	46
	Is the registered control command linked to the desired control command execution condition?	74
	Is the communication operation mode set to "TRANSMITTER" mode? In order to send the control command, set the communication port to "TRANSMITTER" mode. If using LAN, set the IP address and other settings of the connected device.	82
● WEB menu		
Settings are not saved or applied to the operation.	For some WEB menus, settings are not applied until the "SEND" button or "SET" button is clicked.	35

If additional assistance is required, please perform the following tests and then contact us.

No.	Checking items	Result
1	The problem occurs at all connectors?	Yes or No
2	Connect the devices using genuine cables without connecting the SWC-2000. The problem still cannot be solved? Please contact us for assistance.	Yes or No

User Guide of SWC-2000

Ver.1.8.0

Issued on: 2 March 2026



Headquarters

IDK Corporation
7-9-1 Chuo, Yamato-shi, Kanagawa-pref.
242-0021 JAPAN
TEL: +81-46-200-0764 FAX: +81-46-200-0765

Email: idk_eng@idk.co.jp

URL: www.idkav.com

USA

IDK America Inc.
72 Grays Bridge Road Suite 1-C, Brookfield, CT 06804
TEL: +1-203-204-2445

Email: sales@idkav.com

URL: www.idkav.com

Europe

IDK Europe GmbH
Lise-Meitner-Str. 6, D-40878 Ratingen
TEL: +49-2102-578-301-0

Email: info@idkav.eu

URL: www.idkav.com



Product information Support

Arvanics Corporation
7-9-1 Chuo, Yamato-shi, Kanagawa-pref.
242-0021 JAPAN
TEL: +81-46-259-6920 FAX: +81-46-259-6930

Email: info@arvanics.com

URL: www.arvanics.com

Information in this document is subject to change without notice.

©2017 IDK Corporation, all rights reserved. All trademarks mentioned are the property of their respective owners.